

CTP2000 Series Circuit to Packet Platform Quick Start Guide

February 2017
Part Number: 530-033822
Revision 01

This document describes how to install the Juniper Networks[®] CTP2000 Series Circuit to Packet Platform.

Contents

CTP2000 Quick Start Description	3
Step 1: Prepare the Site	3
Before You Unpack the Platform	3
Unpack the Platform	3
Inspect the Components and Accessories	4
If You Detect or Suspect Damage	4
Step 2: Install the Platform	4
Before You Begin Installation	5
Option: Install the Platform in Freestanding Mode	5
Option: Install the Platform in a Rack	5
Step 3: Install Modules and Other Components	6
Module Installation Overview	6
Protect Modules and Slots	6
Required Tools and Safety Items for Installation	7
Safety Guidelines for Installing Modules	7
Install a CTP Interface Module, Processor Module, or Clock Module	8
Install a CompactFlash Card	9
Install a PMC Module	10
Install SFPs	12
Step 4: Connect Cables	13
Cabling Overview	13
Required Tools and Wires for Cabling	13
Connect Management Ports	14
Connect an Interface Module	15
Cable the Platform for Power	15

Step 5: Set Up Access to the CTP Device	16
Console Access	16
Direct Access	17
HyperTerminal Access	17
SSH Access	18
Step 6: Power On	18
Safety Warnings	21
Compliance Statements	22
Federal Communications Commission (FCC) Statement	22
FCC Requirements for Consumer Products	22
Food and Drug Administration, Center for Devices and Radiological Health	23
Canadian Department of Communications Radio Interference Regulations	23
Industry Canada Notice CS-03	23
DOC Explanatory Notes: Equipment Attachment Limitations	23
EC Declaration of Conformity	24
CTP Documentation and Release Notes	25
Requesting Technical Support	26
Self-Help Online Tools and Resources	26
Opening a Case with JTAC	26
Revision History	27

CTP2000 Quick Start Description

This Quick Start contains information you need to install and access the CTP2000 series platform. For complete installation instructions, see the *CTP2000 Series Platform Hardware Documentation* at <https://www.juniper.net/documentation/>.



WARNING: This Quick Start contains a summary of safety warnings in “[Safety Warnings](#)” on page 21. For a complete list of warnings for this router, including translations, see the *CTP2000 Series Platform Hardware Documentation* at <https://www.juniper.net/documentation/>.

Juniper Networks Circuit to Packet (CTP) products provide advanced technology and features required to reliably transport legacy time-division multiplexing (TDM) and other circuit-based applications across next-generation IP networks. CTP platforms create an IP packet flow from a serial data or analog voice connection at one end and provide the necessary processing to re-create the serial bit stream or analog signal from the received packet flow at the other end.

CTP platforms provide compact and lightweight chassis, high port density, and multiple Ethernet interfaces. Each CTP platform runs the CTP operating system (CTPOS) and can be managed by CTPView, a secure Web-based management tool for provisioning, managing, running diagnostics, monitoring, and reporting on all CTP devices and circuits in the network.

Step 1: Prepare the Site

- [Before You Unpack the Platform on page 3](#)
- [Unpack the Platform on page 3](#)
- [Inspect the Components and Accessories on page 4](#)
- [If You Detect or Suspect Damage on page 4](#)

Before You Unpack the Platform

Before you begin unpacking the platform, be sure you have the following tools:

- No. 2 Phillips screwdriver
- Utility knife
- Mechanical lift, or at least two people to assist in lifting

Unpack the Platform

Depending on the platform, it may be delivered boxed, bolted, and strapped to a skid. For your convenience, we recommend that you unpack the device in the location where you want to install it.



WARNING: Three people are required to install the device in a rack: two to lift the device into position and one to screw it to the rack.

To unpack the device:

1. Cut the two straps that secure the carton to the skid, open the carton from the top, and remove the box of accessories that sits on top of the device.
2. Unlock the four plastic clips that hold the box to the skid by squeezing them in their center and pulling out, and then lift the carton off the device.
3. Remove the three screws that attach each of the two L-brackets to the device.
4. To avoid scratching the device when removing it from the skid, detach one of the L-brackets from the skid by removing the three screws.

Inspect the Components and Accessories

After you remove the equipment from the shipping containers:

- Confirm the contents of each container.
- Inspect all external surfaces and external connectors for visible signs of damage.
- Inspect all accessories shipped with each unit.
- Document any damage noted during your inspection.
- Confirm that the device has the correct number and type of modules for your ordered configuration.

If You Detect or Suspect Damage

If you detect or suspect damage to any equipment:

- Contact the shipper responsible for delivery, and formally report the damage.
- Contact your Juniper Networks sales representative or reseller.

Step 2: Install the Platform

- [Before You Begin Installation on page 5](#)
- [Option: Install the Platform in Freestanding Mode on page 5](#)
- [Option: Install the Platform in a Rack on page 5](#)

Before You Begin Installation

Before installing the device:

- Have a plan for installing the device that takes into consideration future expansion.
- Have the tools and accessories needed to complete the installation.
- Be sure that the space requirement of 3 feet (90 cm) behind the device or rack is met. Do not block air vents on the front or back of the router.
- Prepare the equipment racks by measuring and marking space for each device and plenum you plan to install.
- See the “[Safety Warnings](#)” on page 21.

Option: Install the Platform in Freestanding Mode

When installing the device on a table top or in any other freestanding mode, be sure to leave enough space around the device for adequate ventilation. Position the chassis with easy access to the connections that it needs for power, local communications, and remote communications.



WARNING: Two people are required to lift the device.



CAUTION: To prevent electrostatic damage to the device and its components, make sure persons handling the device wear an antistatic device.

Option: Install the Platform in a Rack

To install the device in a rack, you need:

- Phillips screwdriver
- Four 10-32 x 3/8 Phillips screws for each device to be installed

Before installing the devices in a rack, consider the following guidelines:

- You can install up to four CTP2056 chassis in a single 7-ft. (2.1-m) rack. Installing multiple devices in a single rack enables you to maximize your available space.
- Install heavier devices, such as a CTP2056 chassis, on the bottom of the rack. Mount lighter devices higher in the rack.

Following your installation plan, use a tape measure and marking pen to measure and mark space on each equipment rack for each device component. For horizontal spacing, follow Network Equipment Building System (NEBS) requirements.

To install the device in the rack:

1. With one person standing on the left side of the device and another standing on the right side, lift the device into the rack.
2. Position the device in its designated location in the equipment rack. Make sure the holes of the mounting brackets align evenly with the holes of the equipment rack on both sides.
3. Starting at the bottom of the device, have the third person secure the device in the equipment rack by using the 10-32 x 3/8 Phillips screws.

Step 3: Install Modules and Other Components

- [Module Installation Overview on page 6](#)
- [Protect Modules and Slots on page 6](#)
- [Required Tools and Safety Items for Installation on page 7](#)
- [Safety Guidelines for Installing Modules on page 7](#)
- [Install a CTP Interface Module, Processor Module, or Clock Module on page 8](#)
- [Install a CompactFlash Card on page 9](#)
- [Install a PMC Module on page 10](#)
- [Install SFPs on page 12](#)

Module Installation Overview

In CTP2000 series platforms, interface modules can be installed in the front and rear of the device. Rear transition modules (RTMs) are located in the rear of the device.

Interface modules are not hot-swappable.

In CTP2000 series platforms, slot numbering starts at the top of the chassis with slot 0.

Protect Modules and Slots

The CTP2056 has an ESD (electrostatic discharge) grounding jack located in the rear lower-left corner of the chassis near the power switch. To prevent damage from electrostatic discharge, wear an antistatic wrist strap and connect it to one of the jacks when handling components. There are no ESD jacks on the other CTP platforms, so you must use another grounding device.

To protect the modules, components, and slots when installing components, observe the following guidelines:



.....
CAUTION: When handling components, use an antistatic wrist strap connected to an appropriate grounding device. This action helps to protect the module from damage by electrostatic discharge.
.....



CAUTION: Always handle a module by its edges. Do not touch the components, pins, leads, or solder connections.



CAUTION: If you meet strong resistance when attempting to seat a module using the ejectors, remove it from the chassis and confirm that the slot is designed to hold the module. Also, be sure that you have aligned the left and right edges in the correct matching module guides.



CAUTION: Be sure to cover every empty slot with a blank filler panel to protect the device from dust or other foreign substances and to ensure proper device cooling.



CAUTION: Do not discard the antistatic bag. When a module is not in use, store it in an antistatic bag.

Required Tools and Safety Items for Installation

You need the following tools to install a CTP module:

- Phillips screwdriver
- Flathead screwdriver
- ESD wrist strap or other grounding device

Safety Guidelines for Installing Modules

Before and during the installation process, observe the following warnings:



WARNING: Do not work on the device or connect or disconnect cables during lightning activity.



WARNING: Be sure circuit breakers for the power source are in the OFF position before attaching power cables.



WARNING: Remove jewelry (including rings, necklaces, and watches) before working on equipment that is connected to power lines. Metal objects heat up when connected to power and ground and can cause serious burns or become welded to the terminals.



WARNING: Do not insert any metal object, such as a screwdriver, into an open slot or the midplane. Doing so can cause electric shock and serious burns.



WARNING: Never attempt to repair parts of modules yourself. Only trained customer service personnel are authorized to service parts. Call Juniper Networks Customer Service to make arrangements to return defective modules for repair.

Install a CTP Interface Module, Processor Module, or Clock Module

To install a module:

1. Ground yourself by using an antistatic wrist strap or other device, and connect it to one of the ESD grounding jacks.
2. Choose the slot where you want to insert the module.
3. With a Phillips screwdriver, loosen the screws that secure the blank filler panel covering the empty chassis slot, if present, and remove the filler panel.
4. Remove the module from its antistatic bag, being careful not to touch module components, pins, leads, or solder connections.
5. Verify that the ejectors are in the open position (facing outward).
6. Guide the module into the chassis by placing it between the guides of the selected slot and pushing the module until it stops.

The module stops sliding when the ejectors make contact with the chassis.



CAUTION: If you meet strong resistance when attempting to seat the module using the ejectors, remove it from the chassis, and confirm that the slot is designed to hold the component. Also, be sure that you have aligned the left and right edges in the correct matching tracks.

7. Insert the module into the midplane by simultaneously pressing both ejectors inward and exerting forward pressure on the module. The small red release buttons should click into place.
8. Tighten the module's captive screws using a Phillips screwdriver.



NOTE: Tighten the captive screws completely before installing an adjacent module so that proper electromagnetic interference (EMI) gasket compression occurs. Failure to do this can make it difficult to install adjacent modules.

Install a CompactFlash Card

On the CTP2000 series devices with the new PP833 processor, the CompactFlash card is installed on the processor itself (which may be located under an installed PMC card), which prevents insertion or removal of the CompactFlash card until the PMC card is removed. On the CTP2000 series devices with the PP310 and PP332 processors, the CompactFlash card is installed on the processor rear transition module (RTM). Some CTP devices may ship with a CompactFlash card already installed.

To remove or install the CompactFlash card for the CTP2000 series devices with the new PP833 processor (see [Figure 1 on page 9](#)):

1. Power off the unit.
2. If installed, remove the PP833 PMC card by unscrewing the retaining screws and pushing the extractors outward with the latching buttons depressed.
3. You can then remove or install the CompactFlash card in the flash socket.
4. If being used, reinstall the PP833 PMC card into the chassis, and secure the retaining screws.

Figure 1: Installing CompactFlash on the PP833 processor

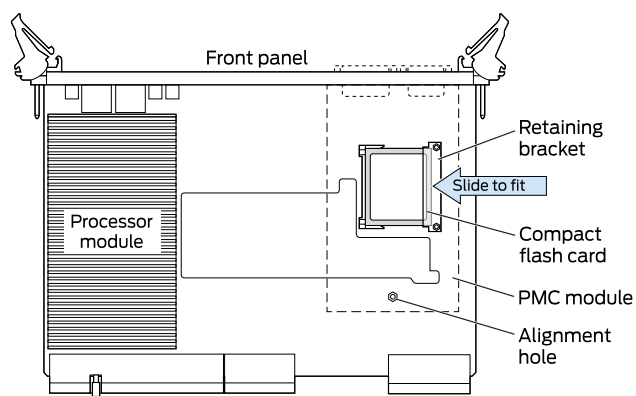

8009630

To remove and reinstall the CompactFlash card for the CTP2000 series devices with the PP310 and PP332 processors:

1. Power off the unit.
2. Remove the RTM by unscrewing the retaining screws and pushing the extractors outward with the latching buttons depressed.
3. Verify that the CompactFlash card is installed.
4. Remove the CompactFlash card—retaining screw and nut. You can then remove or install the CompactFlash card in the flash socket.
5. Reinstall the CompactFlash card—retaining screw and nut.
6. Reinstall the processor RTM into the chassis, and secure the retaining screws.

Figure 2: CompactFlash Card on the RTM

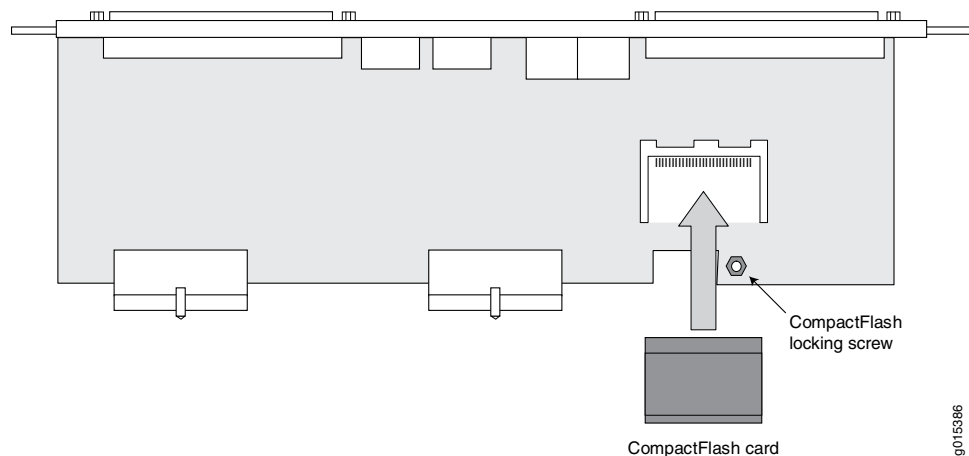

Install a PMC Module

The PMC module is mounted onto the processor module and can be installed or replaced in the field. [Figure 3 on page 11](#) displays the location of the PMC module.

Figure 3: Installing a PMC Module

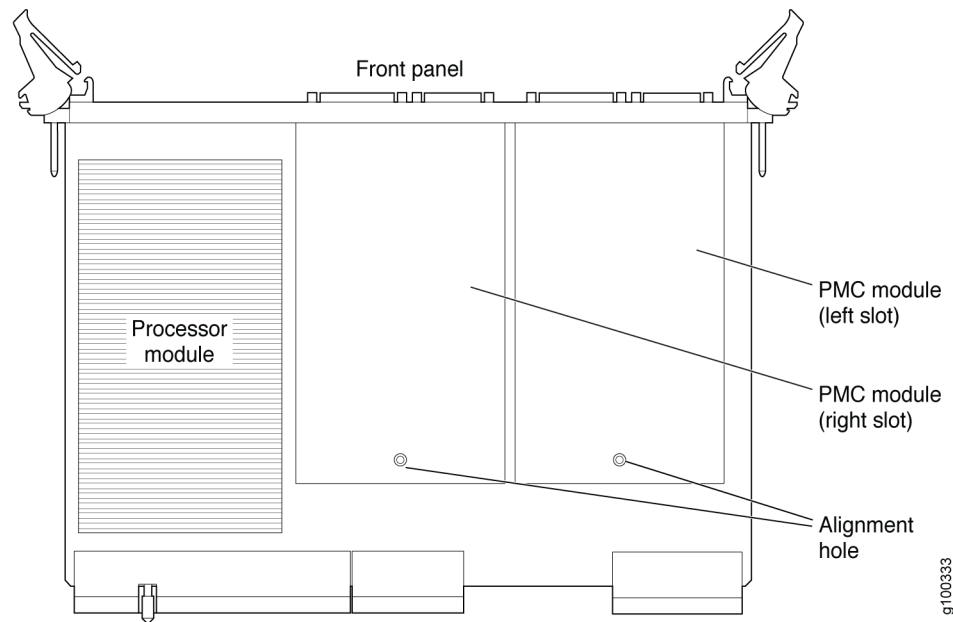

To install a PMC module:

1. Confirm that the device is powered off.
2. Remove the processor module by unscrewing the retaining screws and pushing the extractors outward with the latching buttons depressed.
3. A shield may have been installed in the PMC slot of the processor's front panel. Remove this shield by gently pushing it out from behind the panel.
4. The PMC module has four screws. Two of the screws are secured to standoffs, and two are attached to the front assembly of the PMC module. Remove the two screws secured to the standoff, leaving the standoff attached to the PMC module. Remove the two screws on the front assembly located on the side with the standoffs. The front assembly should remain attached to the PMC hardware. Keep the screws for reattachment.
5. Align the PMC module with the printed circuit board connectors toward the processor board and with the fiber connectors inserted through the processor's front panel. Align the alignment post on the processor module with the PMC module's alignment hole.
6. Gently press the PMC module into the processor module.

7. From the back of the processor module, use the four Phillips head screws to secure the two PMC standoff posts and PMC front assembly to the processor module.
8. Reinstall the processor.

Install SFPs

This section describes how to install small form-factor pluggable transceivers (SFPs) on interface modules that support these devices. In the current release, the CTP-FX2000GE-UPG supports SFPs.

You can replace the SFPs without disabling the interfaces or removing the module from the device.

To install SFPs:

1. Ground yourself by using an antistatic wrist strap or other device, and connect it to an ESD grounding jack.
2. Identify the following items on the SFP ([Figure 4 on page 12](#)):
 - The connection circuitry on the base
 - The cable connectors on the front (which are protected by a dust cover)

Figure 4: Representative SFP

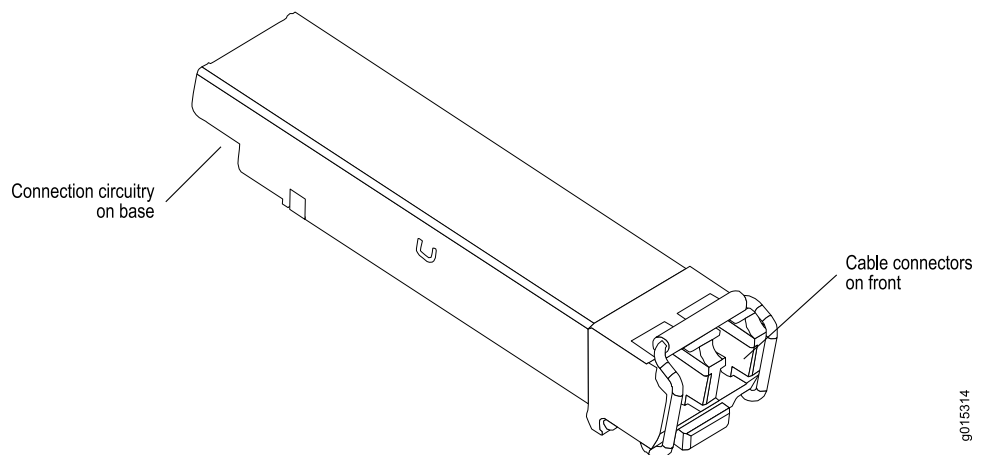

CAUTION: Be sure to position the SFP correctly before you install it.

3. Hold the SFP so that:
 - The connection circuitry is adjacent to the module's faceplate.
 - The cable connectors are visible when you install the SFP.
4. Slide the SFP as far as you can into the module until the SFP clicks into place.

If the SFP does not slide smoothly into the module, make sure that the orientation of the SFP is correct.

5. Gently pull the SFP to confirm that it is inserted correctly.
If the SFP comes out of the slot when you pull it, repeat Step 4.
6. Remove the dust cover that protects the cable connectors.
7. Connect the new cables to the SFP.

Step 4: Connect Cables

- [Cabling Overview on page 13](#)
- [Required Tools and Wires for Cabling on page 13](#)
- [Connect Management Ports on page 14](#)
- [Connect an Interface Module on page 15](#)
- [Cable the Platform for Power on page 15](#)

Cabling Overview

Cabling the device requires the following main tasks:

1. Familiarize yourself with the module ports, and ensure that you have the cables and wires needed to complete each cabling procedure.
2. Read and understand all safety warnings.
3. Connect timing ports.
4. Connect grounding wires to the chassis.
5. Connect the power cables from the power source to the power supply.
6. Connect the interface modules to their appropriate network interface.

Required Tools and Wires for Cabling

Cabling your device takes only a few minutes. You need the following items for proper installation:

- 1/8-inch flathead screwdriver.
- 3/8-inch wrench or 3/8-inch nut-driver.
- No. 2 Phillips screwdriver.

- Ground wires—We recommend a minimum of 18-AWG ground wire for AC and DC-powered versions, if applicable.
- Two #10 kee nuts (supplied) to connect the ground (earth) wire to the ground terminal.
- Power module wiring—We recommend a minimum of 18-AWG wire for the device with a dual stud terminal lug with 5/8-inch spacing.

Consider the distance from the connection point and the configuration of the device when determining the size of wire used.

Connect Management Ports

The management section of the CTP2000 series has one port for management access—a 10/100Base-T Ethernet port that accepts an RJ-45 (male) connector, providing an out-of-band connection for LAN access through an SSH session or SNMP. (See [Figure 5 on page 14](#) and [Figure 6 on page 14](#) for the console port locations on PP310, PP332, and PP833 processors.)

The management port is considered a data terminal equipment (DTE) interface. Direct connection to a terminal or PC (which also has a DTE interface) requires a crossover cable.

Figure 5: Console Port (COM2) Location on PP310 and PP332 processors

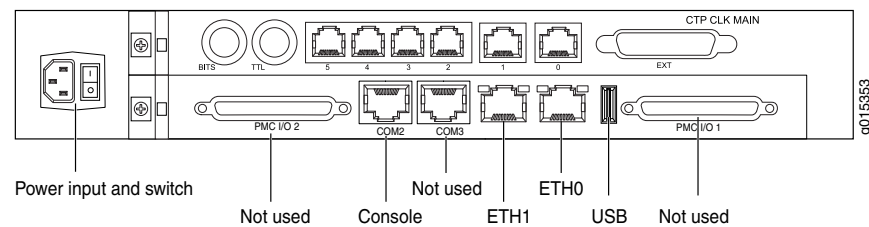
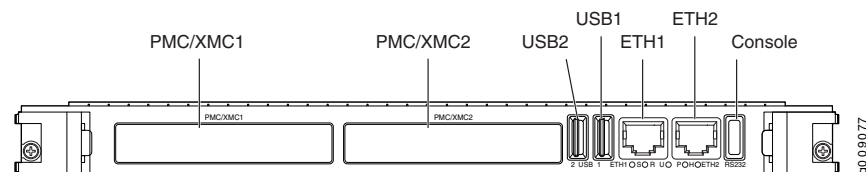

Figure 6: Console Port (RS232) Location on PP833 Processor



To connect the device to the network:

1. Insert an Ethernet cable (RJ-45) connector into the 10/100Base-T (RJ-45) port until it clicks into place.
2. Connect the other end of the cable to the appropriate Ethernet network for an out-of-band connection.

Connect an Interface Module

To install a cable in an interface module (see [Figure 7 on page 15](#) for an example of the 100-pin connectors on the front of the serial interface module):

1. Ground yourself by using an antistatic wrist strap or other device, and connect it to an ESD grounding jack.
2. Remove the dust cover that protects the cable connectors.
3. Slide the cable as far as you can into the module until it clicks into place.
4. Gently pull the cable to confirm that it is inserted correctly.

Figure 7: Connectors on a CTP Serial Interface Module

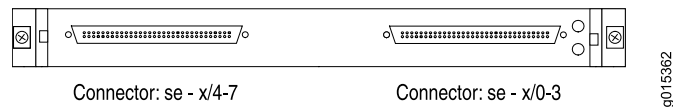

Cable the Platform for Power

After you have correctly cabled the RTM, you must attach grounding and electrical wires before you turn the device on.

Three main tasks are involved:

1. Switch all device power switches to OFF.



CAUTION: Switches may have inadvertently flipped to ON during shipping and installation.

2. Connect the grounding wires to the chassis.



WARNING: Always connect the grounding wires first (before connecting the power cables) and disconnect them last when installing or servicing the device.

3. Connect the power cables to the power supplies.

[Table 1 on page 16](#) identifies the cabling requirements.

Table 1: CTP Power Supply Cables and Wires Needed

Cable/Wire	From	To
One 18-AWG ground wire	PDU ground terminal	Termination ground
Two 18-AWG wire leads	PDU Power A –48 VDC and RTN leads	Appropriate leads on power source No.1
Two 18-AWG wire leads	PDU Power B –48 VDC and RTN leads	Appropriate leads on power source No.2

Step 5: Set Up Access to the CTP Device

- [Console Access on page 16](#)
- [Direct Access on page 17](#)
- [HyperTerminal Access on page 17](#)
- [SSH Access on page 18](#)

Console Access

Before you power on the device, you must set up a management console. You use the console to communicate with the device during the power-on process, to set an IP address, and to manage the device using the command-line interface (CLI).

You can monitor and manage the device through either of these methods:

- **Console terminal**—You can connect a console terminal (PC, Macintosh, or UNIX workstation) directly to the **CONSOLE** terminal port. When you connect a console directly to the device, you can configure the device without an IP address. To communicate with the device, you must have a terminal emulation program running on your PC or Macintosh. You can use any terminal emulation program, such as HyperTerminal. A UNIX workstation can use the emulator TIP.

You can connect a console to the COM2 port on the PP310 and PP332 processors. On the PP833 processor, a console is connected using the supplied USB-to-DB9 cable (p/n 720-071594), in which the DB-9 connector has the same pinout as a standard RS-232 DTE port. When the USB-to-DB9 cable is used in conjunction with the DB-9 adapter labelled “p/n 450-071855”, the available RJ-45 console pinout will be the same as the console connection on the RTM of PP332/PP310 processor.

Alternatively, if the DB-9 adapter from the bag labelled “p/n 720-056657” is used instead of “p/n 450-071855”, the available RJ-45 console pinout will be similar to the CTPI50 console port (and other Juniper routers). To connect the PP833 processor with the DB-9 male serial port of a PC, additionally connect a straight RJ-45 cable with the DB-9 adapter from the bag labelled “p/n 720-056657”. The other end of the RJ-45 cable connects to the DB-9 adapter from the bag labelled “p/n 720-014126”. Then, you can connect the PC’s DB-9 male connector with the DB-9 adapter “p/n 720-014126”.

Refer to the *CTP2000 Series Console Cable Pinouts* section in *CTP2000 Series Hardware Guide* for information about the pinouts of PP310/PP332 and PP833 processor console cables, USB-to-DB9 cable, and DB9-to-RJ45 adapters.

- Remote console—Connect 10/100Base-T to the **CONSOLE** port to an Ethernet network, and run SSH from a remote console.

For initial access to the device, you need to physically connect your console directly to the device's RJ-45 port. Through this connection you use the CLI to set an IP address on the device. After you configure the IP address, you can access the device remotely (for example, through SSH).

Direct Access

When you connect a console directly to the device, use the **CONSOLE** port on the RJ-45 connector. To connect a console directly to the device:

1. Connect the male RJ-45 connector to the **CONSOLE** port.
2. Connect the crossover adapter connector to your PC's serial port.
3. Power on the device.

When you power on the device, the CLI appears on your console's screen..



NOTE: Direct access through the **CONSOLE** serial port enables you to monitor the device while it boots.

HyperTerminal Access

If your console uses a version of Microsoft Windows (such as Windows XP or Windows NT 4.0) that supports the HyperTerminal application, you can access the device through HyperTerminal.

1. Click the **Start** button and select **Programs > Accessories > Communications > HyperTerminal**.
2. In the HyperTerminal window, select **HyperTerminal**.
3. In the Connection Description dialog box, enter a name for your device in the Name field.
4. Select any icon to represent your terminal emulation, and click **OK**.
5. In the Connect To dialog box, in the Connect using field, select the appropriate COM port to use (for example, **COM1**), and click **OK**.
6. In the COM1 Properties dialog box, select the following settings:
 - Bits per second: 9600
 - Data bits: 8

- Parity: None
 - Stop bits: 1
 - Flow control: Xon/Xoff
7. Click **OK**.

SSH Access

When you have configured an IP address for the device, you can run SSH from a host to access the device through its Ethernet port. To connect the Ethernet port to the network:

1. Connect an Ethernet cable (RJ-45) to the device's 10/100Base-T (RJ-45) port on the system processor.
2. Connect the other end of the cable to the appropriate Ethernet network for an out-of-band connection.



CAUTION: Do not change the IP address for the Ethernet interface that you are using to communicate with the device. If you change the address, you will lose the SSH session.

Step 6: Power On



CAUTION: Evaluate the overall loading of the branch circuit before you install any equipment into a rack.

To power on the device:

1. Set up a management console. See [“Step 5: Set Up Access to the CTP Device” on page 16](#).
2. Verify that the power source is operational.
3. Inspect all grounding and power connections to the device chassis.
4. Confirm that all cable connections are secure.
5. Monitor LEDs to verify that the device is booting properly.

The device goes through a boot process. When a prompt appears on the system console, the device is ready to be configured. If the system is new, the device boots to a first boot script. If the system is already operational, it boots to a login prompt.

The series of login prompts requires the following settings:

1. Default username (**ctp**) and password (**ctp**).
2. Password for the root user—The system verifies that the password meets the security profile requirements. However, you can use a noncompliant password by reentering it during the password confirmation prompt.
3. Supported protocol or protocols—(0) IPv4 only, (1) IPv6 only, or (2) IPv4 and IPv6. Enter the appropriate number value.
4. Default interface—From the list of available devices, such as **eth0** and **eth1** (or more), enter the one to be the default.
5. Hostname of the device.
6. IP address of the interface—Enter the IP address of the selected interface, or accept the loopback address (127.0.0.1) by default.
7. Netmask of the IP address—Enter the netmask (such as **255.255.255.128**), or accept 255.255.255.0 as the default.
8. Gateway IP address—Enter the IP address of the gateway, or accept the local address (127.0.0.1) as the default
9. Maximum transmission unit (MTU)—Enter the MTU in bytes, or accept 1500 bytes as the default.
10. Static routes added to the default interface, if any.
11. Date and time GMT (more precisely, UTC)—Enter these separately in digits for the month, day, hour, and minutes in Coordinated Universal Time (UTC), or accept the internal settings.

The device goes into startup mode.

For example:

```

...
***** Setting up the root password *****
Changing root's password!
Changing password for user root.
New password:
Retype new password:
passwd: all authentication tokens updated successfully.
***** Setting up the network *****
Configure supported protocols:

```

```
0) IPv4 Only
1) IPv6 Only
2) IPv4 and IPv6
Please select your option (rtn for 0):

There are 4 ethernet devices available for use. The default device
is the device through which the default gateway can be accessed.

Ctp circuits can run over any ethernet device, default or not.
A default device must be configured, other devices may be configured
and enabled, or disabled. Here is a list of the available devices
and their descriptions:

    eth0: 10/100/1000 Copper (front)
    eth1: 10/100/1000 Copper (back)
    eth2: 1000 Fiber (left)
    eth3: 1000 Fiber (right)

What device would you like to make the IPV4 default device? (rtn for eth0): eth1
OK, eth1 (10/100/1000 Copper (back)) will be configured as IPV4 default device.

Please input the hostname (return for (none)): nova_54

==== Configuration for eth1 (default device):
Please input the ip (return for 127.0.0.1): 172.25.61.54
Please input the netmask (return for 255.255.255.0): 255.255.255.128
Please input the gateway (return for 127.0.0.1): 172.25.61.1
Please input the mtu in bytes (return for 1500):

Add route to interface eth1 [n]

=====
=== OS Security level set to LOW ===
=====

***** Setting up date/time *****
Setting the date (GMT). Please input the year [2008-2020] (return for 2010):

Setting the date (GMT). Please input the month [1-12] (return for 01):

Setting the date (GMT). Please input the day [1-31] (return for 11):

Setting the date (GMT). Please input the hour [0-23] (return for 20):

Setting the date (GMT). Please input the minute [0-59] (return for 22):

INIT: Entering runlevel: 3
Entering non-interactive startup
...
```

During initial power-on, the components of the platform run boot code, go through a series of self-diagnostic tests, and synchronize with each other.

When the tests are completed, use the LEDs on each module to determine the status of the device. Observe the module LEDs on the front or rear components.

Safety Warnings

For your safety, before installing the device, review all safety warnings in this section.



WARNING: The recommended maximum ambient temperature is 40° C (104° F). For safe operation take into consideration the internal temperature within the rack.



WARNING: Install equipment in the rack from the bottom upward. Doing this helps maintain the stability of the rack and reduces the chance of the rack tipping over.



WARNING: Do not insert any metal object, such as a screwdriver, into an open slot or the backplane. Doing so can cause electric shock and serious burns.



WARNING: Three people are required to install the device in a rack: two to lift the device into position and one to screw it to the rack.



WARNING: Connect the device or rack to ground (earth), and ensure that a reliable grounding path is maintained in the rack.



WARNING: Do not work on the device or connect or disconnect cables during lightning activity.



WARNING: Be sure that circuit breakers for the power source are in the OFF position before attaching power cables.



WARNING: Before servicing the device, turn off the power.



WARNING: Remove jewelry (including rings, necklaces, and watches) before working on equipment that is connected to power lines. Metal objects heat up when connected to power and ground and can cause serious burns or become welded to the terminals.



CAUTION: Evaluate the overall loading of the branch circuit before you install any equipment into a rack.

Compliance Statements

- Federal Communications Commission (FCC) Statement on page 22
- FCC Requirements for Consumer Products on page 22
- Food and Drug Administration, Center for Devices and Radiological Health on page 23
- Canadian Department of Communications Radio Interference Regulations on page 23
- Industry Canada Notice CS-03 on page 23
- DOC Explanatory Notes: Equipment Attachment Limitations on page 23
- EC Declaration of Conformity on page 24

Federal Communications Commission (FCC) Statement

This equipment has been tested and found to comply with the limits for a Class A digital device, pursuant to Part 15 of the FCC Rules. These limits are designed to provide reasonable protection against harmful interference when the equipment is operated in a commercial environment. This equipment generates, uses, and can radiate radio frequency energy and, if not installed and used in accordance with the instruction manual, may cause harmful interference to radio communications. Operation of this equipment in a residential area is likely to cause harmful interference in which case the user will be required to correct the interference at his or her own expense.

This equipment is designed for use with properly shielded and terminated cables. Refer to the installation sections of this manual before operation.

Reference: CFR 47, Part 15J, Sect 15.105 April 18, 1989

Caution: Changes or modifications to this equipment not expressly approved by the party responsible for compliance could void the user's authority to operate the equipment.

FCC Requirements for Consumer Products

This equipment complies with FCC rules, Part 68. On the back side of this equipment is a label that contains, among other information, the FCC Registration Number and Ringer Equivalence Number (REN) for this equipment. If requested, provide this information to your telephone company.

If this equipment causes harm to the telephone network, the telephone company may discontinue your service temporarily. If possible, they will notify you in advance. But if advance notice is not practical, you will be notified as soon as possible. You will be advised of your right to file a complaint with the FCC.

Your telephone company may make changes in its facilities, equipment, operations, or procedures that could affect the proper operation of your equipment. If they do, you will be given advance notice to give you an opportunity to maintain uninterrupted service.

If you experience trouble with this equipment, please contact the manufacturer for warranty/repair information. The telephone company may ask that you disconnect this equipment from the network until the problem has been corrected or until you are sure that the equipment is not malfunctioning.

Food and Drug Administration, Center for Devices and Radiological Health

This equipment complies with 21 CFR 1040.10 and 1040.11 for the safe use of lasers.

Canadian Department of Communications Radio Interference Regulations

This Class B (or Class A, if so indicated on the registration label) digital apparatus meets the requirements of the Canadian Interference-Causing Equipment Regulations.

Industry Canada Notice CS-03

The Industry Canada label identifies certified equipment. This certification means that the equipment meets certain telecommunications network protective, operation and safety requirements as prescribed in the appropriate Terminal Equipment Technical Requirements document(s). The Department does not guarantee that the equipment will operate to the user's satisfaction. Before installing this equipment, users should ensure that it is permissible to be connected to the facilities of the local telecommunications company. The equipment must also be installed using an acceptable method of connection. The customer should be aware that compliance with the above conditions may not prevent degradation of service in some situations.

Repairs to certified equipment should be coordinated by a representative designated by the supplier. Any repairs or alterations made by the user to this equipment, or equipment malfunctions, may give the telecommunications company cause to request the user to disconnect the equipment.

Users should ensure for their own protection that the electrical ground connections of the power utility, telephone lines and internal metallic water pipe system, if present, are connected together. This precaution may be particularly important in rural areas.

Caution: Users should not attempt to make such connections themselves, but should contact the appropriate electric inspection authority, or electrician, as appropriate.

Notice: The Ringer Equivalence Number (REN) assigned to each terminal device provides an indication of the maximum number of terminals allowed to be connected to a telephone interface. The termination on an interface may consist of any combination of devices subject only to the requirement that the sum of the Ringer Equivalence Numbers of all the devices does not exceed 5.

DOC Explanatory Notes: Equipment Attachment Limitations

The Canadian Department of Communications label identifies certified equipment. This certification meets certain telecommunication network protective, operational and safety requirements. The department does not guarantee that the equipment will operate to the users satisfaction.

Before installing the equipment, users should ensure that it is permissible to be connected to the facilities of the local telecommunications company. The equipment must also be

installed using an acceptable method of connection. In some cases, the company's inside wiring associated with a single line individual service may be extended by means of a certified connector assembly (telephone extension cord). The customer should be aware that compliance with the above condition may not prevent degradation of service in some situations.

Repairs to certified equipment should be made by an authorized Canadian maintenance facility designated by the supplier. Any repairs or alterations made by the user to this equipment, or equipment malfunctions, may give the telecommunications company cause to request the user to disconnect the equipment.

Users should ensure for their own protection that the electrical ground connections of the power utility, telephone lines and internal metallic water pipe system, if present, are connected together. This precaution may be particularly important in rural areas.

Caution: Users should not attempt to make such connections themselves, but should contact the appropriate electrical inspection authority, or electrician, as appropriate.

EC Declaration of Conformity

Figure 8 on page 25 shows the Declaration of Conformity for CTP2000 platforms.

Figure 8: CTP2000 Series Declaration of Conformity



Declaration of Conformity

Juniper Networks, Inc.
10 Technology Park Drive
Westford, MA 01886 USA

declares that under our sole responsibility the product(s)

**Circuit-to-Packet Network Device
Model CTP2000 Series**

are in conformity with the provisions of the following EC Directives, including all amendments, and with national legislation implementing these directives:

**Low Voltage Directive 73/23/EEC
EMC Directive 89/336/EEC**

and that the following harmonized standards have been applied

EN 60950-1:2001+A11
EN 60825-1:1994+A1+A2

EN 300 386 V1.3.3:2005
EN 55024:1998 +A1 + A2
EN 55022:1998+A1(2000)+A2(2003) Class A

A handwritten signature in cursive script that reads "Susanne Delisle".

Place
Westford, MA, USA

Signature
Susanne Delisle

Date
06/20/2007

CTP Documentation and Release Notes

For a list of related CTP documentation, see
<https://www.juniper.net/documentation/software/junos-jservices/index-main.html>.

If the information in the latest release notes differs from the information in the documentation, follow the *CTPOS Release Notes* and the *CTPView Server Release Notes*.

To obtain the most current version of all Juniper Networks® technical documentation, see the product documentation page on the Juniper Networks website at <https://www.juniper.net/documentation/>.

Requesting Technical Support

Technical product support is available through the Juniper Networks Technical Assistance Center (JTAC). If you are a customer with an active J-Care or JNASC support contract, or are covered under warranty, and need post-sales technical support, you can access our tools and resources online or open a case with JTAC.

- JTAC policies—For a complete understanding of our JTAC procedures and policies, review the JTAC User Guide located at <https://www.juniper.net/customers/support/downloads/7100059-EN.pdf>.
- Product warranties—For product warranty information, visit <https://www.juniper.net/support/warranty/>.
- JTAC hours of operation—The JTAC centers have resources available 24 hours a day, 7 days a week, 365 days a year.

Self-Help Online Tools and Resources

For quick and easy problem resolution, Juniper Networks has designed an online self-service portal called the Customer Support Center (CSC) that provides you with the following features:

- Find CSC offerings: <https://www.juniper.net/customers/support/>
- Search for known bugs: <http://www2.juniper.net/kb/>
- Find product documentation: <https://www.juniper.net/documentation/>
- Find solutions and answer questions using our Knowledge Base: <https://kb.juniper.net/>
- Download the latest versions of software and review release notes: <https://www.juniper.net/customers/csc/software/>
- Search technical bulletins for relevant hardware and software notifications: <https://www.juniper.net/alerts/>
- Join and participate in the Juniper Networks Community Forum: <https://www.juniper.net/company/communities/>
- Open a case online in the CSC Case Management tool: <https://www.juniper.net/cm/>

To verify service entitlement by product serial number, use our Serial Number Entitlement (SNE) Tool: <https://tools.juniper.net/SerialNumberEntitlementSearch/>

Opening a Case with JTAC

You can open a case with JTAC on the Web or by telephone.

- Use the Case Management tool in the CSC at <https://www.juniper.net/cm/>.
- Call 1-888-314-JTAC (1-888-314-5822 toll-free in the USA, Canada, and Mexico).

For international or direct-dial options in countries without toll-free numbers, see <https://www.juniper.net/support/requesting support.html>.

Revision History

February 2017—Revision 2

Copyright © 2017, Juniper Networks, Inc. All rights reserved.

Juniper Networks, the Juniper Networks logo, JUNOS, NetScreen, ScreenOS, and Steel-Belted Radius are registered trademarks of Juniper Networks, Inc. in the United States and other countries. JUNOSe is a trademark of Juniper Networks, Inc. All other trademarks, service marks, registered trademarks, or registered service marks are the property of their respective owners.

Juniper Networks assumes no responsibility for any inaccuracies in this document. Juniper Networks reserves the right to change, modify, transfer, or otherwise revise this publication without notice.

Products made or sold by Juniper Networks or components thereof might be covered by one or more of the following patents that are owned by or licensed to Juniper Networks: U.S. Patent Nos. 5,473,599, 5,905,725, 5,909,440, 6,192,051, 6,333,650, 6,359,479, 6,406,312, 6,429,706, 6,459,579, 6,493,347, 6,538,518, 6,538,899, 6,552,918, 6,567,902, 6,578,186, and 6,590,785.