

# Connecting Physical and Virtual Worlds with VMware NSX and Juniper Platforms

---

A Joint Juniper Networks-VMware White Paper

## Table of Contents

Executive Summary .....	4
Introduction: Network Virtualization with NSX .....	4
Control Plane.....	6
Data Plane .....	6
Extending Virtual Networks to Physical Space with Layer 2 Gateways .....	6
Use Cases.....	7
Physical Tier .....	7
Physical to Virtual (P2V) Migration.....	7
Attach Physical Network Services/Appliances.....	7
Connect Physical and Virtualized Data Centers.....	7
IT as a Service (ITaaS) .....	7
Software Gateway.....	8
Hardware Gateway .....	8
Technical Overview of the Solution.....	9
Common NSX Components.....	9
Physical Network Infrastructure .....	9
Hypervisors and Virtual Switches .....	9
Tunnels .....	9
Service Nodes .....	10
Controller Cluster.....	10
NSX Manager .....	10
Redundancy.....	10
Software Layer 2 Gateway .....	10
Configuration.....	10
Redundancy.....	11
Traffic Flow Example.....	11
Hardware Layer 2 Gateway.....	13
OVSDB Support on Juniper NSX L2 Gateway .....	14
Redundancy/Multihoming .....	15
Traffic Flow Example.....	15
Juniper Platforms for Layer 2 Hardware Gateway .....	17
VMware-Certified QFX5100 Switch.....	18
EX9200 .....	18
MX Series.....	18
Deployment Scenarios for Layer 2 Hardware Gateway.....	18
Bridging Physical and Virtual Tiers in Multitier Application Architectures .....	18
Migrating Apps from Physical to Virtual Servers.....	19
Attach Physical Network Services/Appliances.....	19
Connect Physical and Virtualized Data Centers.....	19
IT as a Service (ITaaS) .....	20
Architectures for Deploying L2 NSX Gateway Using Juniper Platforms and Technologies.....	20
Layer 3 IP Clos/ECMP .....	20
Virtual Chassis Fabric Switching Architecture .....	21
VMware NSX Integration with Juniper vSRX Firewall.....	23

Integrated Network Management and Automation.....	24
Network Director Integration with VMware vCenter .....	25
Network Director Integration with VMware NSX .....	25
Juniper Content Management Packs for VMware vRealize.....	26
Conclusion.....	27
About Juniper Networks.....	27

## List of Figures

Figure 1: Virtual network view.....	5
Figure 2: Transport network view.....	5
Figure 3: Layer 2 gateway use cases.....	7
Figure 4: Software L2 gateway.....	8
Figure 5: Hardware L2 gateway.....	8
Figure 6: NSX components overview.....	9
Figure 7: L2 gateway OVS configuration by the controller cluster.....	11
Figure 8: Redundant software L2 gateways.....	11
Figure 9: Logical network for traffic flow example.....	12
Figure 10: ARP request from VM1.....	12
Figure 11: ARP reply from Server S.....	13
Figure 12: L2 hardware gateway.....	14
Figure 13: OVSDDB on L2 hardware gateway.....	14
Figure 14: L2 hardware gateway packet flow—ARP request.....	15
Figure 15: L2 hardware gateway packet flow—ARP response.....	16
Figure 16: L2 hardware gateway packet flow—unicast traffic.....	17
Figure 17: Attach physical tier.....	18
Figure 18: Attach physical network services/appliances.....	19
Figure 19: Connecting physical and virtualized data centers.....	20
Figure 20: IT as a Service (ITaaS).....	20
Figure 21: Juniper L3 IP Clos architecture.....	21
Figure 22: Juniper Virtual Chassis Fabric.....	23
Figure 23: vSRX, Security Director, and VMware NSX Integration Workflow.....	24
Figure 24: Network Director's integration with VMware vCenter Server and NSX controller.....	25
Figure 25: Overlay and underlay visibility in Junos Space Network Director.....	25

## Executive Summary

This document is targeted at networking and virtualization architects interested in deploying VMware NSX network virtualization in a multi-hypervisor environment based on the integrated solution from VMware and Juniper.

VMware's Software Defined Data Center (SDDC) vision leverages core data center virtualization technologies to transform data center economics and business agility through automation and nondisruptive deployment that embraces and extends existing compute, network, and storage infrastructure investments. NSX is the component providing the networking virtualization pillar of this vision. As a platform, NSX provides partners the capability of integrating their solutions and building on top of existing functionalities. NSX enables an agile overlay infrastructure for public and private cloud environments leveraging Juniper's robust and resilient underlay infrastructure that also helps bridge the physical and virtual worlds using the Layer 2 gateway functionality. In addition, Juniper's vSRX Virtual Firewall also integrates with NSX to offer advanced L4-7 protection for east-west data center traffic.

The first part of this document presents a summary of the benefits of NSX and some use cases for a Layer 2 gateway service. The second part focuses on the integration of Juniper switching, routing, and security platforms with NSX.

## Introduction: Network Virtualization with NSX

Server virtualization has dramatically changed the way compute resources are consumed in a data center. With the introduction of the hypervisor, which is a thin layer of software abstracting the server hardware, virtualization brought to the market straightforward benefits, including the fact that several virtual machines could now be consolidated on fewer, cheaper generic devices. But a second wave of innovation followed, directly resulting from the flexibility of a software model. A compute administrator can now expect to instantiate a virtual machine (VM) on demand, move it from one physical location to another with no service interruption, and get high availability, snapshot capabilities, and many other high-value features that were just not imaginable in a purely physical environment.

Today, an application is more than software running on a single server. It typically requires communication between several tiers of resources through some network components, and the agility in the compute space must directly map to the same flexibility in the networking space. Indeed, as networking is all about forwarding traffic to a determined location, if compute virtualization allows the location of compute resources to move freely, it is necessary to update the networking components of those moves. The possible solutions considered before NSX were:

- Manual reconfiguration of the network: The complexity of the interaction between networking, security, storage, and compute teams makes this solution very slow and only suitable to small, static environments.
- Complete automation of the network devices: Ideally, all of the network devices would have similar characteristics and could have their configuration entirely automated. This model was never possible to achieve across vendors, even with OpenFlow.
- Layer 2-based solutions: Most networking vendors have worked to enhance those solutions, but L2 still provides flexibility at the expense of scale. Stable implementations require segmenting the data center in one way or another, reintroducing the silos that virtualization is trying to fight.

Network reachability is not the only challenge these solutions are trying to address. They show the same limitations when it's a matter of implementing end-to-end security policies, or inserting services like load balancing, for example.

NSX is taking an approach very similar to compute virtualization. With server virtualization, a software abstraction layer (server hypervisor) reproduces the familiar attributes of a physical server (e.g., CPU, RAM, disk, NIC) in software, allowing them to be programmatically assembled in any arbitrary combination to produce a unique VM in a matter of seconds. With network virtualization, the functional equivalent of a "network hypervisor" reproduces the complete set of L2 to L7 networking services (e.g., switching, routing, access control, firewalling, quality of service, and load balancing) in software. As a result, they too can be programmatically assembled in any arbitrary combination, this time to produce a unique virtual network in a matter of seconds.

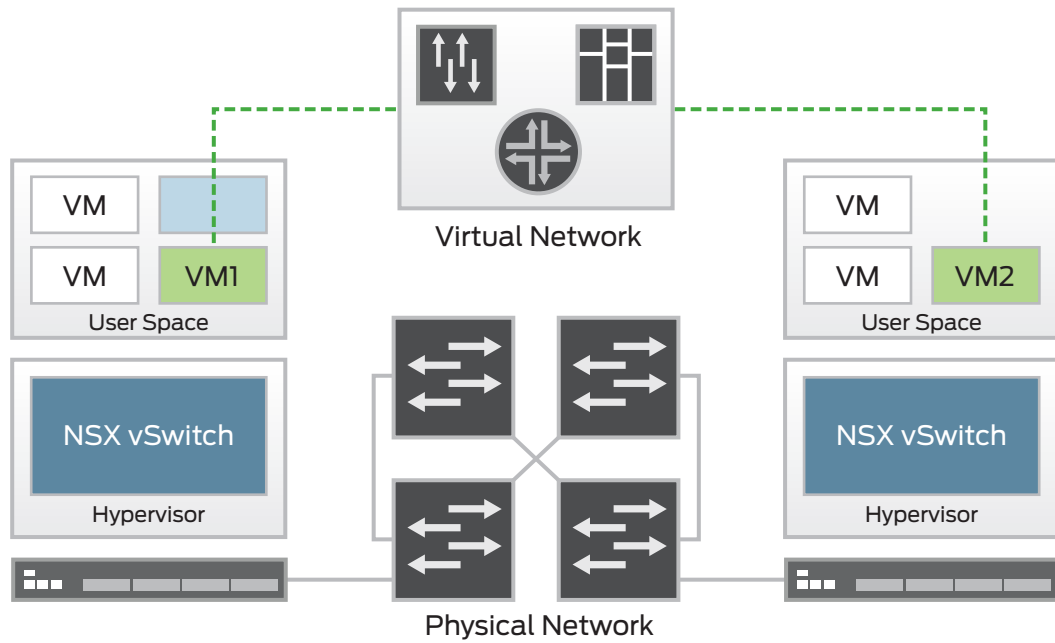

Figure 1: Virtual network view

In Figure 1, NSX presents to the virtual machines a virtualized version of all the traditional networking functions. Those virtual functions are achieved in a distributed fashion, across the different hosts in the data center. Taking the example of traffic moving between VM1 and VM2, everything looks from a logical standpoint like this traffic is going through some network devices: routers, switches, firewalls, etc. Traffic, however, is really following the path represented in Figure 2.

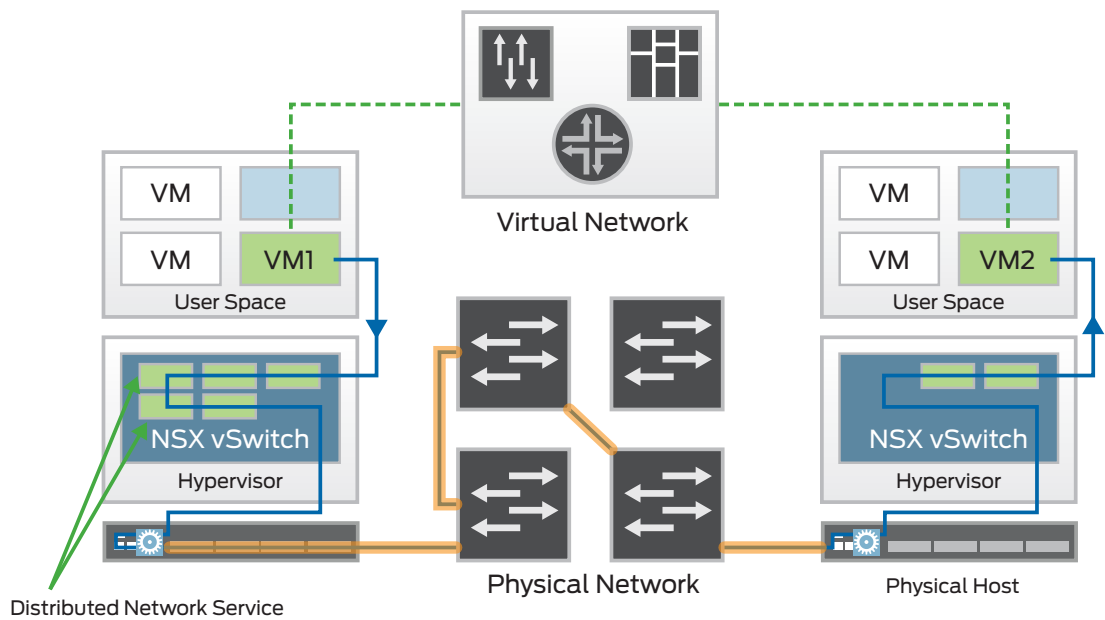

Figure 2: Transport network view

Traffic from VM1 is being fed to local instances of the switches, router, and firewall, implemented by NSX on the host. Those local instances determine that the destination of the traffic is on a remote host, where VM2 is located. They encapsulate the traffic and forward it to the remote host, where after decapsulation, it is finally presented to the target VM2, as if it had gone through a physical instantiation of those services. The tunnel (represented in orange in the diagram) is seen as plain IP traffic from the point of view of networking infrastructure, and does not require any particular functionality from the physical network.

## Control Plane

The control plane disseminates the network state for the distributed components like the NSX vSwitches such that they can create the required tunnels and switch the data packets appropriately. In NSX, the control plane is controlled and managed by the NSX controller cluster. This is a highly available distributed clustered application that runs on x86 servers. The one key aspect about the NSX controller cluster is that it does not sit in the data path. It is designed to manage and control thousands of switching devices.

## Data Plane

The distributed components responsible for forwarding VM are the NSX vSwitches. They provide the network functions for tunneling, queuing management, security, and packet scheduling. The NSX vSwitches are managed by the controller cluster, but once they have been configured, they are able to perform their task independently, even if the controller cluster were to fail completely. As represented in Figure 2, NSX vSwitches create an overlay by establishing IP tunnels between them. This document will focus on Virtual Extensible LAN (VXLAN) as a tunnel encapsulation, as it is the industry standard required by Juniper for the integration of their switches as hardware Layer 2 gateways. NSX vSwitches can thus exchange data and perform their advanced functions without introducing any dependency to the underlying network. The latter only needs to be able to efficiently switch IP traffic between hosts while providing high availability.

In summary:

- NSX does not introduce any requirement on the physical network and provides its advanced features over multivendor or legacy networks.
- NSX is fast, flexible, and simplifies networking by providing automation. A virtual network can be provisioned in minutes, and there is no need to go through an error-prone configuration of all the physical devices so that they have a consistent view of the VLANs, the firewall filters, or the firewall rules, for example.
- NSX is scalable and efficient; virtual switches run in kernel space and, as a result, NSX introduces minimal overhead at the edge. Traffic is also forwarded to its final destination using an optimal path. For example, there is never a need for “hair-pinning” traffic through a firewall when the firewall functionality is directly implemented in a virtual switch running on the local hypervisor.
- NSX has been able to satisfy the requirements of the largest providers in the world, thanks to its distributed and scale-out model.

## Extending Virtual Networks to Physical Space with Layer 2 Gateways

NSX operates efficiently using a “network hypervisor” layer, distributed across all hosts. However, in some cases, certain hosts in the network are not virtualized and cannot implement the NSX components natively. Thus, NSX provides the ability to bridge or route toward external, non-virtualized networks. This document is more specifically focused on the bridging solution, where a Layer 2 gateway bridges between a logical L2 network and a physical L2 network. This section will go over some use cases and introduce the different form factors for the L2 gateway functionality, including the hardware-based L2 gateway functionality on Juniper’s switching and routing platforms.

The main functionality that a Layer 2 gateway achieves is:

- Map an NSX logical switch to a VLAN. The configuration and management of the L2 gateway is embedded in NSX.
- Traffic received on the NSX logical switch via a tunnel is decapsulated and forwarded to the appropriate port/VLAN on the physical network. Similarly, VLAN traffic in the other direction is encapsulated and forwarded appropriately on the NSX logical switch.

The combination of Juniper and VMware optimizes applications and data center operational efficiencies by:

- Enabling programmatic connection of VLANs to logical networks offering the choice of NSX L2 gateway services across access switches, core/aggregation switches, and edge routers to bridge virtual and physical networks in any data center topology
- Providing foundation for hardware accelerated VXLAN routing to support virtualized network multitenancy and enable VM mobility over distance for business continuity/disaster recovery and resource pooling

- Allowing flexible workload placement and workload mobility
- Delivering a single pane of glass (NSX API) for configuring logical networks across hypervisors and physical switches
- Eliminating the need for IP multicast for the physical network

## Use Cases

Because virtualization introduces significant benefits in terms of flexibility, automation, and management in the data center, companies typically try to virtualize as much of their infrastructure as they can. However, there are some cases where total virtualization is not possible and where a gateway from logical to physical world is necessary. Following is a list of use cases for this service:

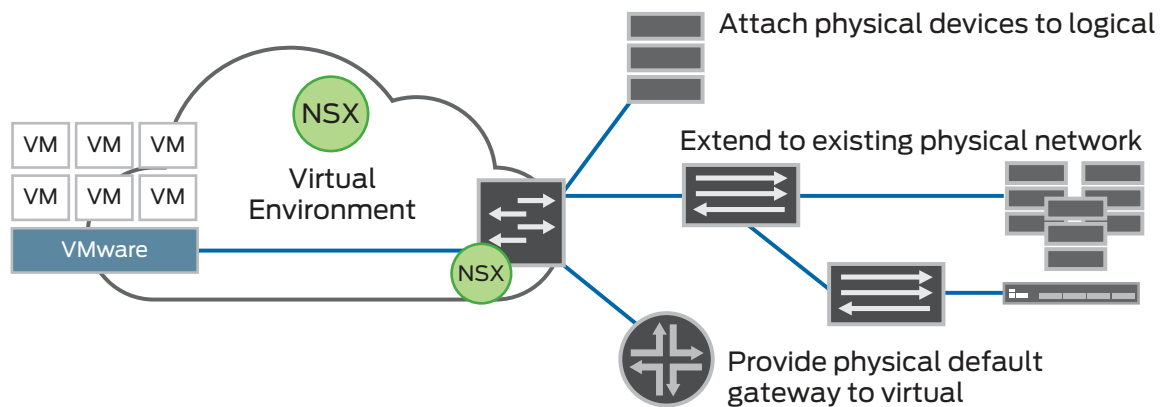

Figure 3: Layer 2 gateway use cases

### Physical Tier

Because of licensing or performance issues, some database servers cannot be run as virtual machines. The result is that a single application tier must reside in a physical space, but the vast majority of the workloads can still be virtualized. The extension of a logical switch to the physical world using an L2 gateway still allows getting as many of the virtualization benefits as possible in that case.

### Physical to Virtual (P2V) Migration

Another use case of gateway functionality is the migration of workload from physical to virtual that typically requires preservation of the IP address (L2 domain) during the migration process. Extending a logical switch to a physical L2 network allows virtualizing servers with minimal impact on their configuration. As a result, a newly virtualized server can maintain connectivity with its peers whether they are virtual or physical, allowing for a safe, incremental virtualization of the data center.

### Attach Physical Network Services/Appliances

Some services, like firewall, load balancers, or default gateways, might already exist under a physical form factor in the data center, and it might not be practical or even possible to virtualize them (in some cases, those devices might be servicing both virtual and physical parts of the network, for example.) Extending the NSX logical switches into the physical world will allow VMs to easily leverage those physical services. These physical resources can be within or across data centers.

### Connect Physical and Virtualized Data Centers

Customers want to segment their physical data centers from their virtualized ones. If a workload needs to traverse the two, using an L2 NSX gateway might be a deployment option. This option would also be useful in hybrid cloud deployments comprised of an on-premises physical data center with a remote private or public virtualized data center.

### IT as a Service (ITaaS)

For an IT as a Service (ITaaS) environment, keeping tenants separate is very important. In many cases, different tenants are accessing shared physical resources, but into their own virtual domains. The L2 NSX gateway is the ideal demarcation point to be able to separate traffic from individual users into each virtual domain (VXLAN-to-VLAN).

## Software Gateway

NSX natively includes a software version of the L2 gateway functionality. It can be implemented as a virtual machine or as an appliance form factor (meaning a software version running directly on an x86 physical server).

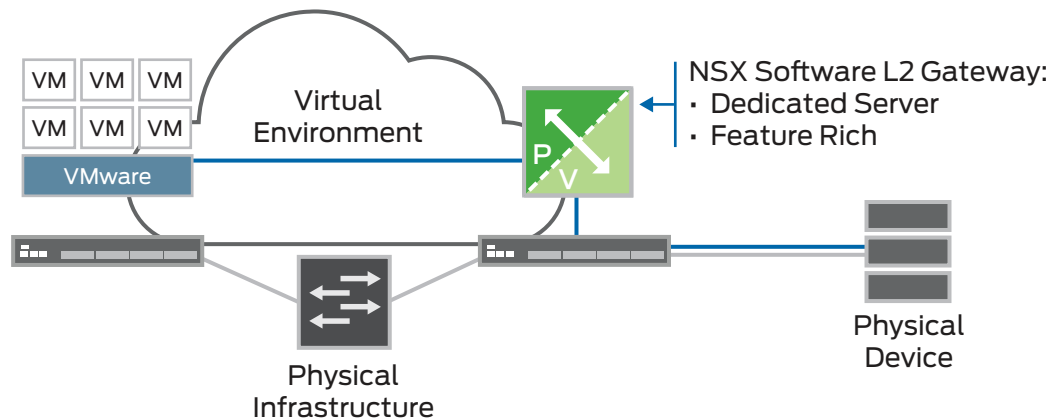

Figure 4: Software L2 gateway

Benefits of software L2 gateway:

- The functionality can be provided leveraging a generic server, as qualified by the customer's IT department.
- Modern servers can typically achieve wire-rate performance on 10 Gbps network interface cards (NICs). In most cases, this is enough bandwidth for physical/virtual communication.
- The L2 gateway being implemented in software is benefiting from all of the features and capabilities of the NSX release it belongs to.

## Hardware Gateway

NSX as a platform allows the integration of third-party components, and the L2 gateway functionality can be achieved in hardware. This document will cover in detail the capabilities of Juniper Networks® QFX5100 Switch and EX9200 Ethernet Switch, as well as MX Series 3D Universal Edge Routers acting as a hardware Layer 2 NSX gateway.

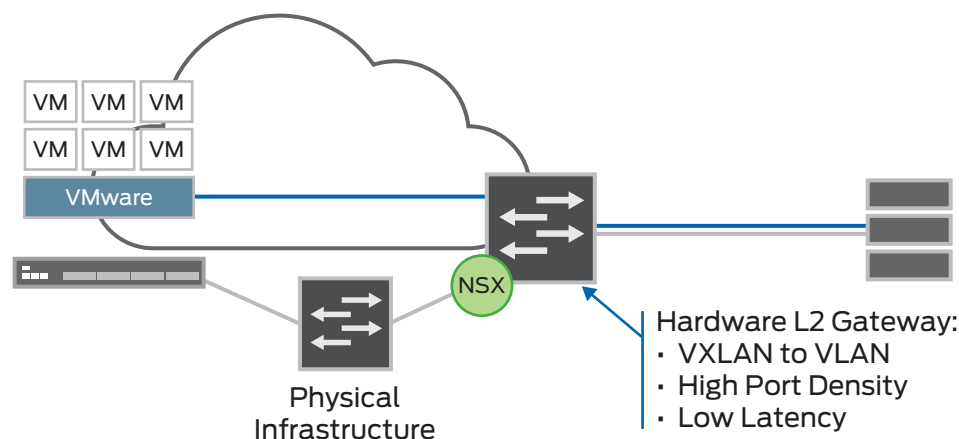

Figure 5: Hardware L2 gateway

Hardware L2 gateway provides several benefits, including:

- Port density: Juniper switches support deployments that scale from dozens to thousands of ports. This port density allows for the connection of many devices as well as providing high bandwidth and redundancy to the NSX fabric. The section on Juniper platforms provides more details on the scale and performance of various models.
- Deterministic performance and latency: Hardware forwarding latency is not impacted by whether the gateway is dealing with a new flow, an existing flow, or a small or large packet. This results in lower latency, predictable and optimal traffic flow, and higher throughput.





## Service Nodes

Service nodes provide some functionality that requires central processing for added performance. In the context of this paper focusing on L2, a relevant responsibility assigned to service nodes is the handling of Broadcast, Unknown Unicast, and Multicast (a.k.a. BUM) traffic. As mentioned earlier, NSX does not rely on IP multicast. When a VM sitting on a hypervisor needs to flood traffic to all of the devices attached to the same logical switch, the virtual switch sends this traffic to a service node that, in turn, forwards it to all of the appropriate hypervisors (i.e., hypervisors that are hosting at least one VM connected to the particular logical switch).

## Controller Cluster

The controller cluster is a distributed system that runs on a set of x86 servers and is responsible for running the control plane of the NSX domain. The controller cluster accepts logical network configuration instructions from tenants and administrators through NSX API. The responsibilities of the controller cluster also include the instantiation of the components of a distributed logical switch. For example, when a VM is instantiated on a hypervisor, the controller cluster configures the components that implement the logical switch to which this VM is attached. It is also responsible for programming the media access control (MAC) address table that will be used to reach other VMs attached to the logical switch.

The controller cluster also exposes Web service APIs (NSX APIs) that can be used, for example, by a Cloud Management System (CMS) to instruct the controller to create logical ports and logical networks and connect VMs to them.

## NSX Manager

The NSX Manager offers a web-based GUI that provides a user-friendly method of interacting with the NSX API for management and troubleshooting. The NSX Manager is hence used to interact with the NSX APIs exposed by the controller for configuring transport networks and logical switches and connecting VMs to these logical switches. However, in real-life deployments, it is expected that the deployment and management of those logical switches will be automated through a Cloud Management Platform (like OpenStack or CloudStack, for example). In other words, the NSX Manager is not designed for day-to-day provisioning or automated “wizard-based” configuration, and as such its role is not critical in the context of the NSX architecture.

## Redundancy

NSX is built with high availability in mind, and the components critical for maintaining continuous operation are redundant. This section describes how this redundancy is achieved.

- Tunnel redundancy is ensured by the redundant underlying IP infrastructure.
- Multiple service nodes are available in the network for redundancy and load sharing. A periodic keep alive is sent from the hypervisors to the service nodes. If a hypervisor determines that a service node is down, it can immediately switch to another one.
- The controller cluster comprises several nodes, for scale out and redundancy. Typically, a controller cluster is made up of an odd number of nodes so that in case of partition, a majority can still accept configuration changes, while the minority cannot and just maintains its state until it rejoins the majority. The controller cluster assigns two different nodes, one active and one standby, for each virtual device it is managing in NSX. If the active node fails, the standby takes over immediately and another standby is built from another available node in the cluster. If a standby node fails, a new one is created from another available node in the cluster. Note also that if both active and standby fail simultaneously, traffic is not interrupted while replacement nodes are elected.
- The NSX Manager does not store states and does not need redundancy. A new NSX Manager can be created should the previous one fail.
- Layer 2 gateway redundancy is specific to the software and hardware L2 gateway and will thus be addressed in their respective sections.

## Software Layer 2 Gateway

Software NSX gateways can be deployed in production as physical (x86 bare metal servers) or VMs.

## Configuration

As already mentioned, NSX is using a virtual switch in order to handle the network traffic. All of the devices in NSX running this virtual switch are called transport nodes. In the case of the Layer 2 gateway, this virtual switch is an OVS and responsible for performing the data plane operations. OVS is controlled in two different ways by the controller cluster:

- The management of the virtual switch is achieved via the OVS DataBase (OVSDB). The database contains information such as the set of logical switches that the OVS must handle, the list of associated physical ports, as well as configuration information as statistics for those ports. The Layer 2 gateway runs an OVSDB server. Typically, a local client and a client on the controller clusters connect to this server. Using OVSDB, the controller cluster can thus coordinate different parameters across the whole NSX domain.
- The configuration of the flow, for forwarding traffic in the data plane, is directly achieved via OpenFlow.

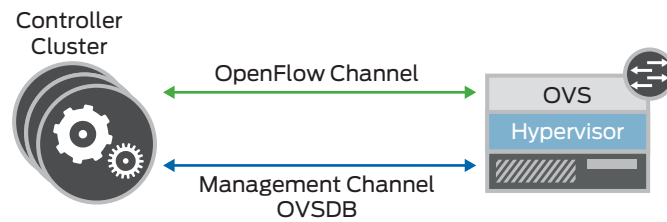

Figure 7: L2 gateway OVS configuration by the controller cluster

### Redundancy

NSX L2 gateway services act as a gateway between logical network space controlled by NSX and external physical networks.

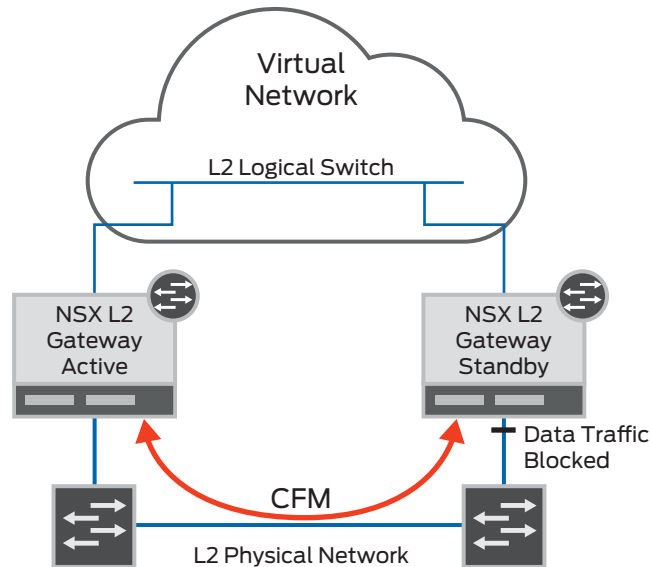

Figure 8: Redundant software L2 gateways

Because the NSX controller cluster is not aware of the Layer 2 topology to which gateways connect, gateways must perform loop prevention to avoid possible L2 loops. An example of this is represented in Figure 8, where two L2 gateways are attached to the same physical L2 network. There is the potential for a loop between the NSX domain and the physical L2 network through the two gateways. NSX prevents such loops by ensuring that at most one active L2 gateway is attached to the same physical L2 network. L2 gateways use Ethernet connectivity fault management (CFM) frames on the physical L2 network to detect if there are any other L2 gateways on the same network. CFM frames are multicast frames and each contains an ID representing the L2 gateway. If an L2 gateway hears from another L2 gateway on the same segment with an ID lower than its own, it becomes inactive, breaking any loop. The unique CFM ID used as a tie-breaker is assigned to each L2 gateway by the NSX controller. Note that the loop detection mechanism also serves as a redundancy mechanism. If the active gateway becomes inactive, the standby can start forwarding frames.

Using Bidirectional Forwarding Detection (BFD), the L2 gateways are also polling the service nodes over the tunnels leading to them in order to check their liveness. In case a service node is deemed unavailable, the gateway will switch over to another active one.

### Traffic Flow Example

This section introduces the way traffic is forwarded through a Layer 2 Gateway in NSX, taking a very simple example of a virtual machine resolving the IP address-to-MAC address binding of an external server using the Address Resolution Protocol (ARP). The logical view of the network considered is represented in Figure 9.

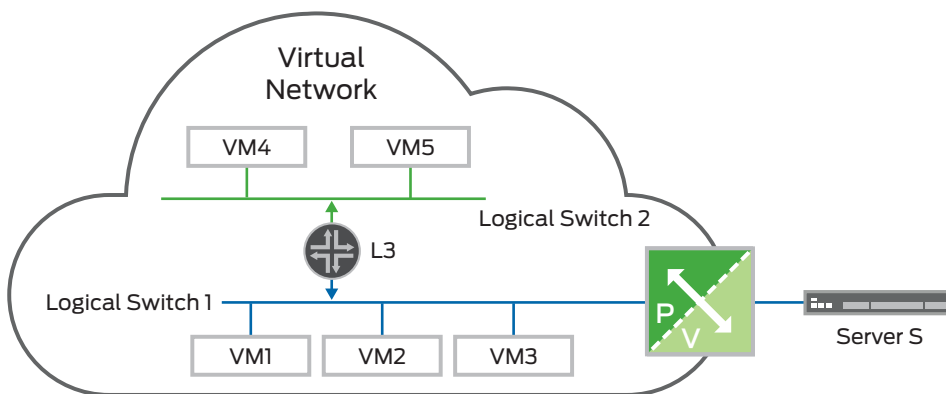

Figure 9: Logical network for traffic flow example

The virtual machine VM1 is connected to logical switch 1, which itself is extended through an L2 gateway to the physical world. Server S is thus on the same broadcast domain as VM1. Another logical switch (logical switch 2) as well as several other virtual machines are represented in order to illustrate the way NSX is flooding frames.

The physical representation of the network is depicted in Figure 10. The different VMs are spread across several hosts running Hypervisor 1 to Hypervisor 3. The red arrows in the diagram represent the ARP request flooded from VM1, in search of server S.

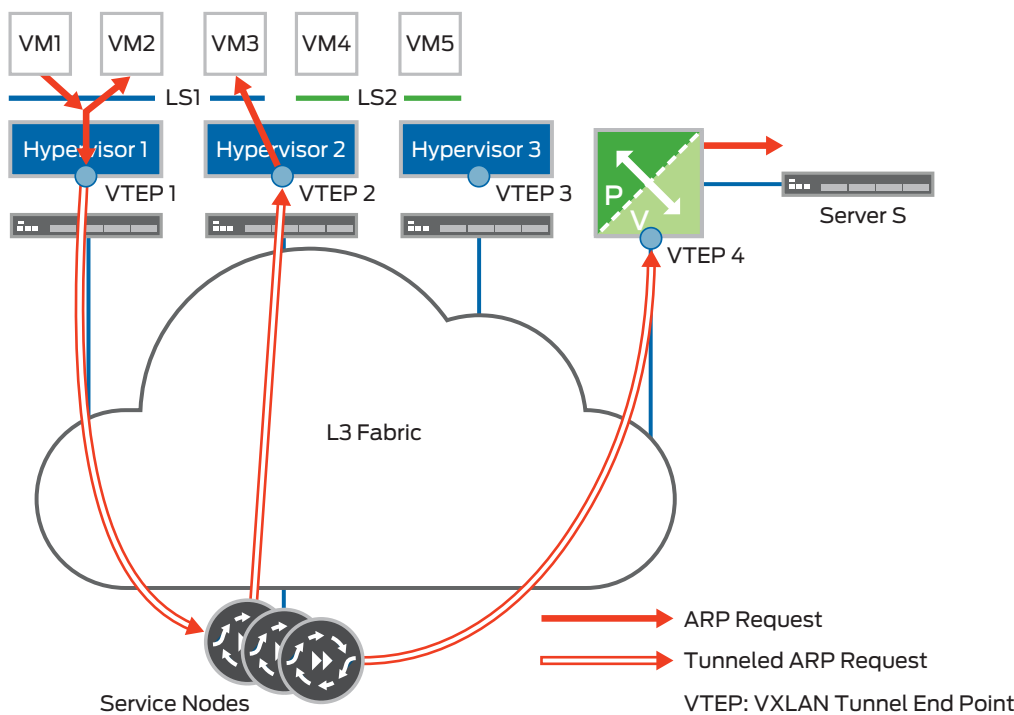

Figure 10: ARP request from VM1

The ARP request from VM1 is received by the virtual switch on Hypervisor 1. Because VM2 is in the same broadcast domain as VM1, the virtual switch on Hypervisor 1 is directly forwarding the request to VM2. There are other remote members of logical switch 1, so the virtual switch on Hypervisor 1 is also forwarding the ARP request to a service node via its VXLAN Tunnel End Point (VTEP). From the VTEP, this packet is encapsulated using VXLAN.

The service node determines the recipients for the flooded traffic. Hypervisor 3 does not host any VM on logical switch 1, so the service node will only relay the ARP request to Hypervisor 2 and the L2 gateway service. Note also that the virtual switch on Hypervisor 2 only forwards the packet to VM3, as VM4 is on a different broadcast domain. NSX dynamically limits the scope of flooded traffic.

The L2 gateway receives the VXLAN encapsulated packet and floods it toward server S, based on the logical switch to port/VLAN mapping configured by OVSDb.

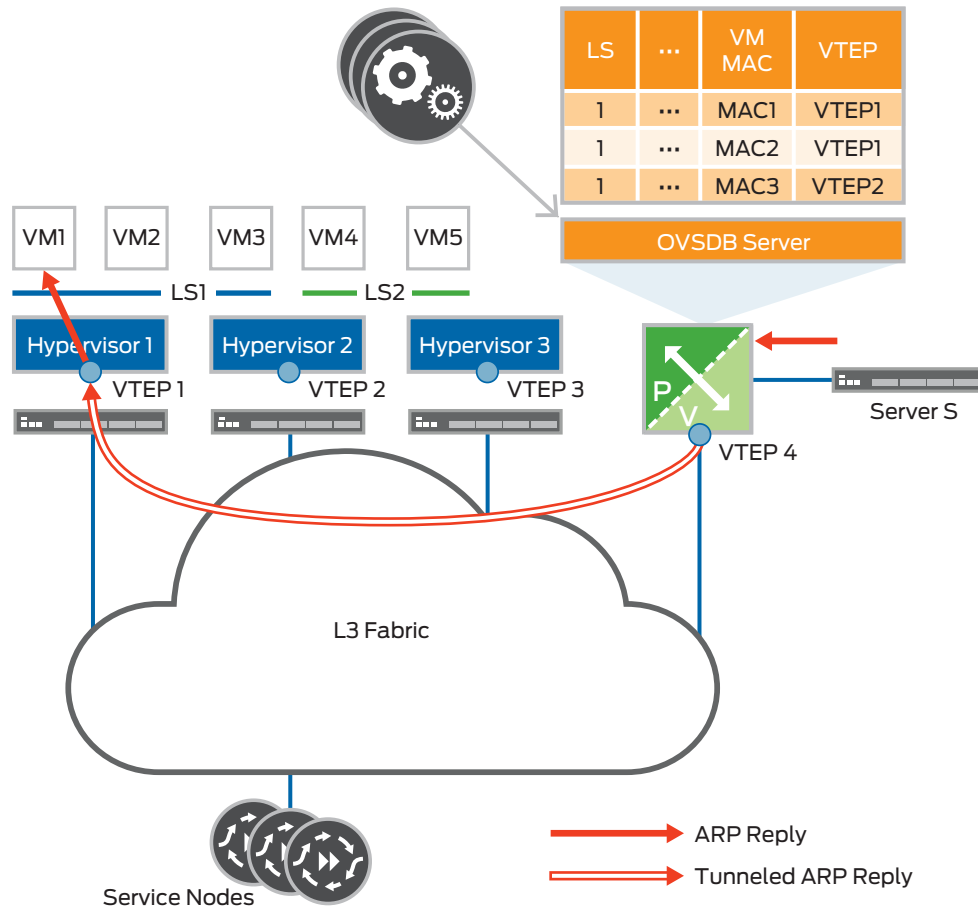

Figure 11: ARP reply from Server S

Server S receives the broadcast ARP request and sends a unicast reply to VM1. As shown in Figure 11, the OVSDb server in the L2 gateway has been prepopulated by the controller cluster to hold (among other fields) the MAC address/VTEP association for all of the VMs known in logical switch 1. As a result of a lookup in this table, the L2 gateway can determine the target VTEP1 to which the packet is directly tunneled. The virtual switch on Hypervisor 1 eventually delivers the decapsulated unicast ARP reply to VM1 only.

### Hardware Layer 2 Gateway

Hardware Layer 2 gateway provides connectivity within the same broadcast domain, as if the devices were connected to the same physical switch. L2 hardware gateway provides simple and easy connectivity between workloads attached to a VMware NSX logical network and bare-metal workloads, traditional/legacy virtualized workloads, and network appliances such as firewall and load balancers.

L2 hardware gateway minimizes disruption and provides a smoother migration path for legacy and bare-metal resources.

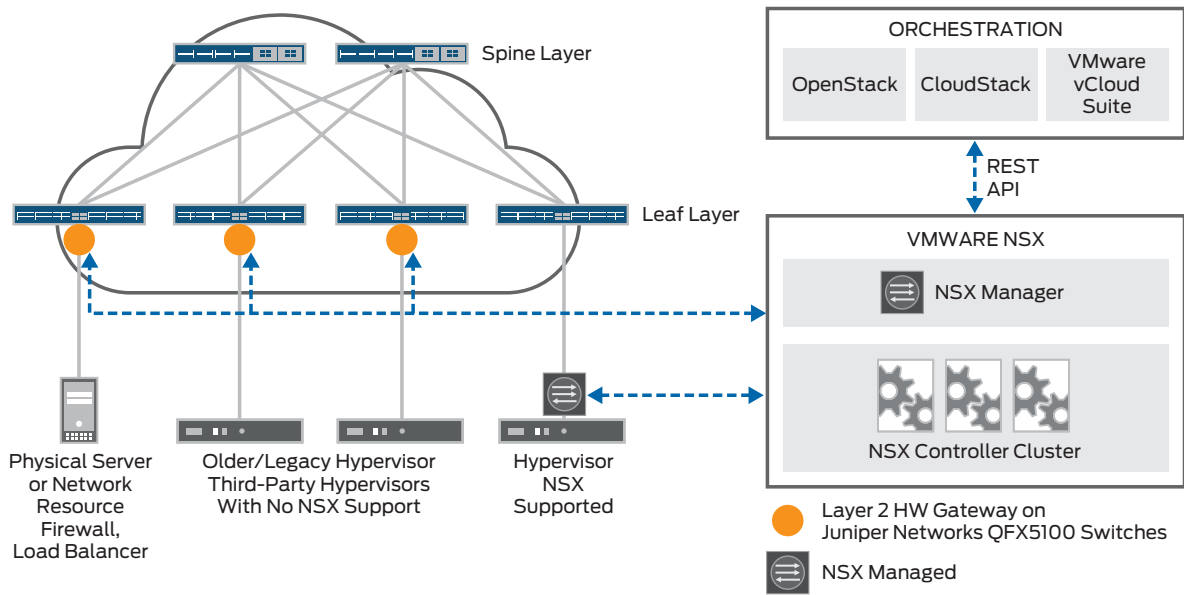

Figure 12: L2 hardware gateway

**OVSDB Support on Juniper NSX L2 Gateway**

Juniper Networks NSX L2 gateway services enable VXLAN-to-VLAN (or physical port) capabilities at any tier of the data center network, from server access to the data center edge. The Juniper NSX L2 gateway integrates with NSX through data plane (VXLAN) and control plane (OVSDDB) protocols while unifying the management plane. This integration delivers L2 gateway services that discover non-virtualized and other assets in the data center, enabling seamless communication with virtualized assets by linking VXLAN tunnels to VLANs in the physical network. Users can also manage and operate workloads spanning virtual and non-virtualized systems from NSX as a single pane of glass.

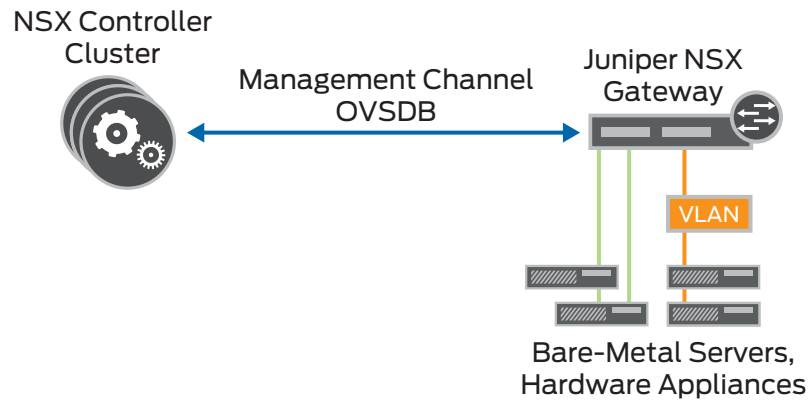

Figure 13: OVSDDB on L2 hardware gateway

To enable communication between NSX controllers and Juniper Networks Junos® operating system devices, the Junos OS implementation of OVSDDB includes an OVSDDB server as well as an OVSDDB client that runs on each Junos OS device that supports OVSDDB.

The OVSDDB server stores and maintains a schema that contains control and statistical information provided by the OVSDDB client on the Junos OS devices and NSX controllers. This information is stored in various tables in the schema. The OVSDDB client on the Junos OS devices and NSX controllers monitors the schema for additions, deletions, and modifications of information and uses that information.

The schema provides a means through which the Junos OS devices and the NSX controllers can exchange information. For example, the Junos OS devices capture MAC addresses to entities in the physical network (“local”) and push this information to a table in the OVSDDB schema so that NSX controllers with connections to these Junos OS devices can access the MAC addresses. Conversely, NSX controllers capture MAC addresses to entities in the virtual network (“remote”) and push this information to a table in the OVSDDB schema so that Junos OS devices with connections to the NSX controllers can access the MAC addresses.

## Redundancy/Multihoming

Virtualized servers, bare-metal servers, and network services/appliances, among others, can multihome to two or more L2 hardware NSX gateway devices for redundancy. If a network node functioning as an L2 NSX gateway fails, the alternate node continues to service traffic for the servers or network appliances. The protocols and mechanisms for supporting node redundancy is based on the data center fabric architecture. As an example, Juniper Networks Virtual Chassis Fabric technology natively supports resiliency without any explicit configuration, as multiple network nodes act as logical line cards in one large chassis providing unified management and control. These aspects are discussed in more detail in the section on deployment architectures.

## Traffic Flow Example

Multicast in underlay is not required as Broadcast, Unknown Unicast, and Multicast (BUM) traffic is handled by a service node that performs the replication. Replication for BUM traffic can be performed on the L2 hardware gateway for optimal performance instead of leveraging the software-based service node.

The following diagrams illustrate the packet handling in an NSX environment with hardware L2 gateway. In the following example, IP1 and IP2 VMs are connected to Hypervisor 1, and a bare-metal server IP5 is connected to the Juniper L2 NSX gateway. Software VTEP is created on Hypervisor 1, and a hardware VTEP is created on Juniper L2 NSX gateway as a part of the NSX configuration. Hypervisor 1, L2 NSX gateway, and NSX service nodes are connected to each other using the same VXLAN network identifier (VNI) (L2/broadcast domain).

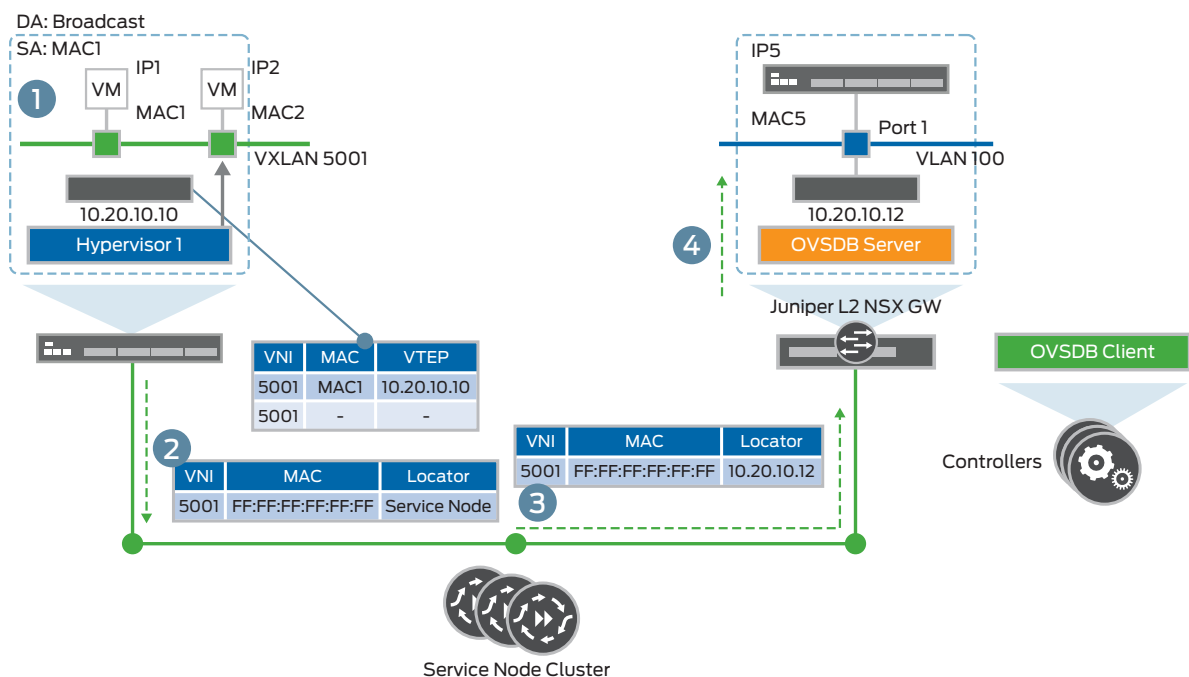

Figure 14: L2 hardware gateway packet flow—ARP request

Consider the traffic from VM IP1 on Host1 (Hypervisor 1) to bare-metal server (IP5) connected to the Juniper L2 NSX gateway.

1. VM IP1 wants to reach IP5 but does not have its MAC address and sends out an ARP request.
2. VTEP on Hypervisor 1 learns the MAC address of VM IP1 and encapsulates the ARP request (for IP5) in VXLAN and sends it to one of the NSX service nodes based on the next-hop/remote VTEP information in the “Locator” field.
3. Service node replicates the ARP to other hypervisors and hardware VTEPs on Juniper L2 NSX gateway for the particular logical switch (same VNI) using VXLAN encapsulation.
4. Hardware VTEP on Juniper L2 NSX gateway decapsulates the VXLAN and forwards the ARP requests to connected interfaces/VMs (IP5) for the same logical switch (VNI).

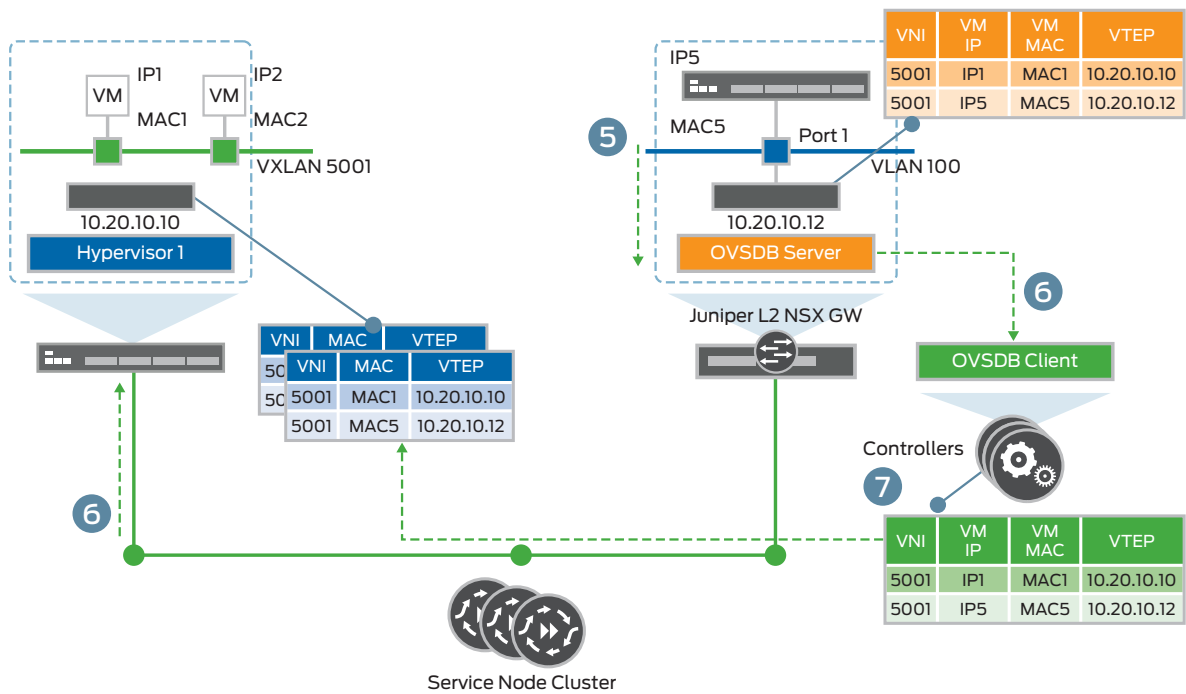

Figure 15: L2 hardware gateway packet flow—ARP response

5. IP5 receives the ARP packet from L2 NSX gateway and the ARP response from IP5 is sent out to Mac1.
6. VTEP on Juniper L2 NSX gateway receives the packet and performs a lookup on Mac1 to identify remote VTEP. It encapsulates the ARP response in VXLAN and sends it across to Hypervisor 1/VTEP. Also, hardware VTEP on L2 NSX gateway learns the source MAC address for IP5 and updates the NSX controller with VXLAN tunnel IP/MAC mapping entries.
7. NSX controller floods the mapping information (mac5 -> IP5) to other VTEPs ensuring that all relevant VTEPs have consistent mappings.



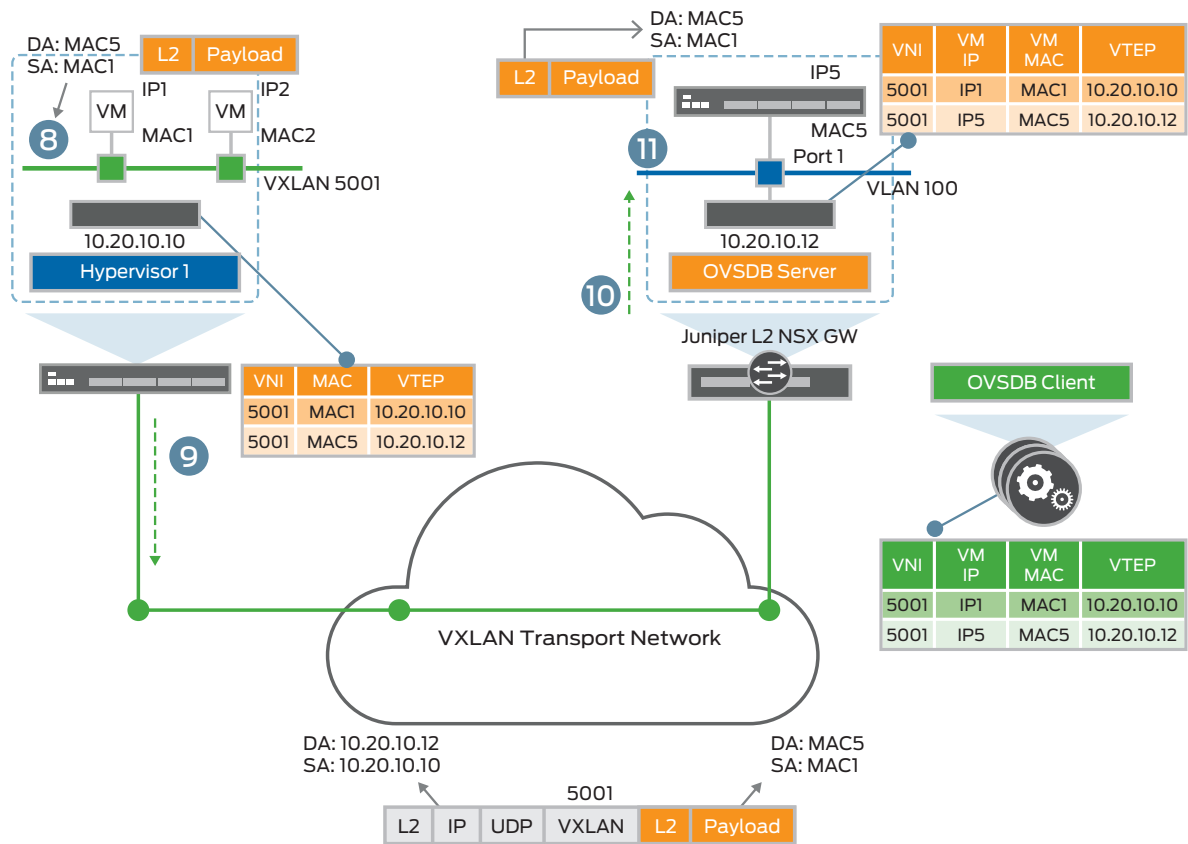

Figure 16: L2 hardware gateway packet flow—unicast traffic

8. Unicast data traffic from VM IP1/MAC1 is now sent across to IP5/MAC5 as all the relevant ARP information is learned.
9. VTEP/Hypervisor 1 encapsulates the traffic using VXLAN and sends it directly to hardware VTEP/L2 NSX gateway. VXLAN encapsulation is illustrated in the diagram depicted in Figure 16.
10. Hardware VTEP/L2 NSX gateway decapsulates the VXLAN packets and sends them across to IP5.
11. IP5 receives the unicast packets and processes them.

### Juniper Platforms for Layer 2 Hardware Gateway

L2 hardware gateway functionality is supported on a wide range of switching and routing platforms from Juniper. These include the VMware-certified QFX5100 switches, as well as the EX9200 switches and MX Series routers.

Table 1. Juniper Networks L2 Hardware Gateway Platforms

Juniper Platform	Junos OS Software	Role	Use Case
QFX5100	14.1X53-D10	Top-of-rack data center aggregation switch	<ul style="list-style-type: none"> <li>• Physical tier</li> <li>• Physical to virtual (P2V) migration</li> <li>• Attach physical network services/appliances</li> </ul>
EX9200	14.2R1	Data center aggregation/core switch	<ul style="list-style-type: none"> <li>• P2V data center connectivity</li> <li>• IT as a Service (ITaaS)</li> </ul>
MX Series routers	14.1R2	WAN/data center edge router	<ul style="list-style-type: none"> <li>• Attach physical network services/appliances</li> </ul>

\*Target availability: 2H 2014

### VMware-Certified QFX5100 Switch

The QFX5100 line of flexible, high-performance, low-latency, and feature-rich Layer 2 and Layer 3 switches are optimized for virtualized data center environments and are ideal for top-of-rack as well as data center aggregation deployments of various densities and speeds. This flagship platform from Juniper integrates with VMware NSX and includes several features such as MPLS, Fibre Channel over Ethernet (FCoE), and the industry's only topology-independent in-service-software upgrade (TISSU) capability. QFX5100 switches can be deployed in various data center fabric architectures such as Virtual Chassis Fabric, multichassis link aggregation (MC-LAG), and Layer 3 IP Clos (spine/leaf).

The QFX5100 supports both dynamic provisioning (via NSX) as well as manual provisioning of VXLAN overlay tunnels.

### EX9200

The EX9200 line of programmable and modular Ethernet switches simplifies the deployment of cloud applications in data center core/aggregation environments, serving as an ideal choice for data center consolidation and interconnection.

### MX Series

The MX Series is a family of high-performance, modular Ethernet services routers with powerful switching features. The MX Series devices are designed for high-performance service providers and enterprises, and they are commonly deployed in the data center core and interconnect as well as edge/core transport networks.

Both the EX9200 switch and MX Series routing platforms support OVSDDB for integration with NSX. They can be deployed in standalone mode or in L3 Clos architectures, and can support L2 as well as L3 NSX gateway functionality. They can also be used to perform ingress replication for BUM traffic instead of using service node for the replication functionality. Along with supporting the VXLAN-to-VLAN mapping, MX Series routers and EX9200 switches support flexible mapping options from VXLAN to MPLS/VPLS or VXLAN to E-VPN.

## Deployment Scenarios for Layer 2 Hardware Gateway

### Bridging Physical and Virtual Tiers in Multitier Application Architectures

Today, applications are deployed in a multitier (multilayer) manner in which presentation, application processing, and data management functions are separated and can be deployed on virtualized or bare-metal servers. By segregating an application into tiers, developers have the option of modifying or adding a specific layer instead of reworking the entire application. Three-tier architectures are commonly chosen and are composed of a presentation tier, a domain logic tier, and a data storage tier.

Anywhere from 40%-60% of servers today are virtualized, and while this number is on a definite upward trend, there remain applications that still sit on non-virtualized servers. There could be many reasons for this—the application might be tied to specific hardware, driver, license, or performance requirements, among others.

Because of licensing or performance issues, some database servers cannot be run as virtual machines. The result is that a single application tier must reside on bare metal, but the vast majority of the workloads can still be virtualized. The extension of a logical switch to the physical world using a L2 hardware gateway still provides many of the virtualization benefits.

As illustrated in the following diagram, the QFX5100 can be used as a L2 NSX gateway to enable bridging of physical/bare-metal and virtual tiers.

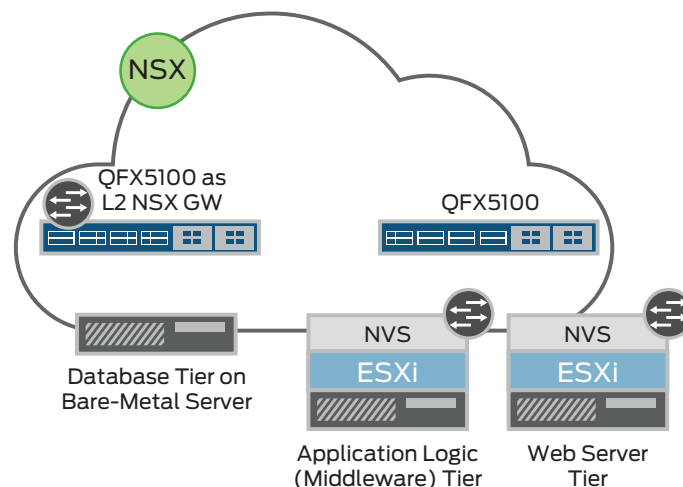

Figure 17: Attach physical tier

### Migrating Apps from Physical to Virtual Servers

As noted earlier, an increasing number of applications are being migrated from physical servers to virtualized instances for gaining the numerous virtualization benefits such as workload mobility, efficient resource utilization, greater uptime, and accelerated deployment, among others. Migration can be a complex activity that may require significant downtime. L2 NSX gateway functionality can be leveraged in simplifying the migration of workload from physical to virtual by preserving the IP address/subnet (L2 domain) during the migration process. Extending a logical switch to a physical L2 network allows virtualizing servers with minimal impact on their configuration. As a result, the newly virtualized server can maintain connectivity with its peers, whether they are virtual or physical, allowing for a safe, incremental virtualization of the data center.

The VMware-certified QFX5100, serving as a Layer 2 NSX gateway, is an ideal choice for enabling the P2V migration.

### Attach Physical Network Services/Appliances

Some services such as firewalls, load balancers, or default (router) gateways might already exist under a physical form factor in the data center. In this case, it might not be practical or even possible to virtualize them (when those devices are servicing both virtual and physical parts of the network, for example). Extending the NSX logical switches into the physical world will allow virtual machines to easily leverage those physical services. These physical resources can be within or across data centers. The QFX5100 serving as a L2 NSX gateway can support both VLAN and physical interfaces to connect to the physical resources, providing flexible deployment options.

As illustrated below, the Juniper L2 NSX gateway can be used to attach physical network appliances such as firewalls, load balancers, routers, and switches. The QFX5100 and EX9200 switches, as well as the MX Series routers, can act as a L2 NSX gateway for interconnecting these physical network services/appliances.

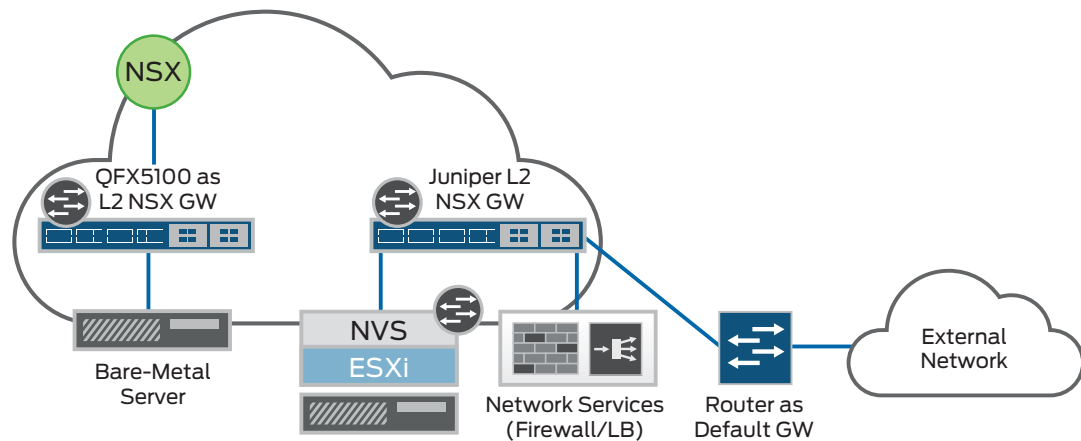

Figure 18: Attach physical network services/appliances

### Connect Physical and Virtualized Data Centers

The L2 NSX gateway in the data center edge can help connect the VMs in the virtualized data center and the bare-metal resources in the physical data center using the NSX overlay solution. This option could also be useful in migrating to public clouds or enabling hybrid cloud deployments comprising on-premises physical data centers with a remote private or public virtualized data center. Further, many customers segment their physical data centers from their virtual ones. If a workload needs to traverse the two, delivering the gateway capabilities at the core switch or edge router is the best deployment option.

As illustrated below, EX9200 Ethernet switches and MX Series routers acting as L2 NSX gateways can be used to connect a data center with physical workloads (VLAN) to a virtualized data center (VXLAN-based). Both these data centers can be interconnected using an IP/MPLS network, and VXLAN-based services (VLAN-to-VXLAN) provided by L2 NSX gateway enables a Layer 2 interconnection between them. This ensures seamless workload mobility across these physical and virtual data centers. A single VLAN-VXLAN or multiple VLAN-VXLAN mappings can be enabled in this scenario. VXLANs stretched across the data center can also be enabled using EX9200 switches or MX Series routers.

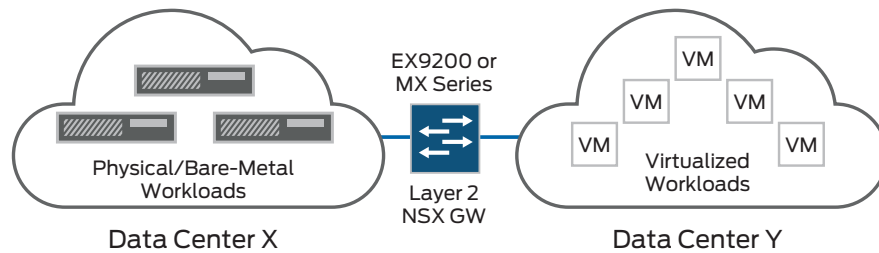

Figure 19: Connecting physical and virtualized data centers

### IT as a Service (ITaaS)

In an ITaaS scenario, keeping tenants separate is very important. In many cases, different tenants in their own virtual domain are in need of securely accessing shared physical resources. Providers for ITaaS services create logical virtual domains for each tenant that are secure and separate from each other but leveraging the same shared infrastructure. A L2 NSX gateway at the core switch or edge router is the ideal demarcation point to be able to separate traffic from individual users into each virtual domain (VXLAN-to-VLAN). Both EX9200 switches and MX Series routers can support several thousand VLAN-to-VXLAN mappings to enable L2 connectivity across their data center and the shared infrastructure/virtual network. Each of the customers leverage a single VLAN-to-VXLAN mapping or multiple VLAN-to-VXLAN mappings based on their requirement. As with the previous use case, given the L2 connectivity, workload mobility can be seamlessly supported by this approach.

The following diagram illustrates the EX9200 or MX Series router providing the L2 NSX functionality and enabling the ITaaS provider in offering secure services.

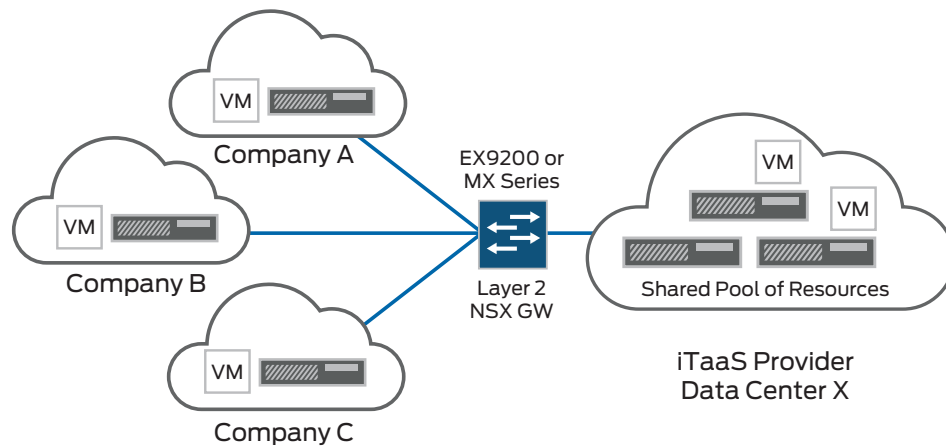

Figure 20: IT as a Service (ITaaS)

## Architectures for Deploying L2 NSX Gateway Using Juniper Platforms and Technologies

NSX L2 gateway functionality on several Juniper platforms can be deployed in a flexible set of deployment architectures. These include standalone, L3 Clos (spine/leaf), Virtual Chassis, and Virtual Chassis Fabric spine/leaf modes. We describe the two most common architectures—L3 IP Clos and Virtual Chassis Fabric—deployed by customers based on the scale, need for converged network, manageability, and other considerations/requirements.

### Layer 3 IP Clos/ECMP

Clos networks are a kind of multistage circuit switching network, first formalized by Charles Clos in the 1950s.

This architecture delivers high bandwidth, low latency, and nonblocking connectivity that is key for large-scale modern data centers, including massively scalable data center deployments.

Layer 3 Clos networks are commonly employed as the data center fabric in three-stage architectures comprising several leaf nodes connected to all spine nodes. These are typically running BGP between the leaf and spine nodes to achieve high performance and resiliency. Equal-cost multipath (ECMP) mechanisms are used to load-share traffic across multiple spines (N-way multipathing).

The advantage of a Clos topology is that it can be nonblocking and allows predictable performance and scaling characteristics, given that each leaf/access node is always reachable by another leaf/access node through just one spine/aggregation device.

Server multihoming for bare-metal/virtualized servers (NIC teaming-based) can be achieved by enabling Virtual Chassis in the top-of-rack/data center access layer wherein two switches act as a single logical device with a single IP address.

Overlay technologies such as VXLAN or L2 NSX gateway can be used to provide VM mobility across server nodes. Further, L3 Clos can also be extended as a full-mesh overlay fabric based on VXLAN to enable seamless mobility and service agility across the network.

L3 Clos architectures can scale to over 100,000 servers, and they can be built using QFX5100, EX9200, or MX Series devices. The following diagram illustrates the L3 Clos architecture composed of four spine nodes and several leaf nodes. The L2 NSX gateway feature is enabled on each of the leaf nodes connected to the bare-metal servers, physical appliances, or legacy hypervisors.

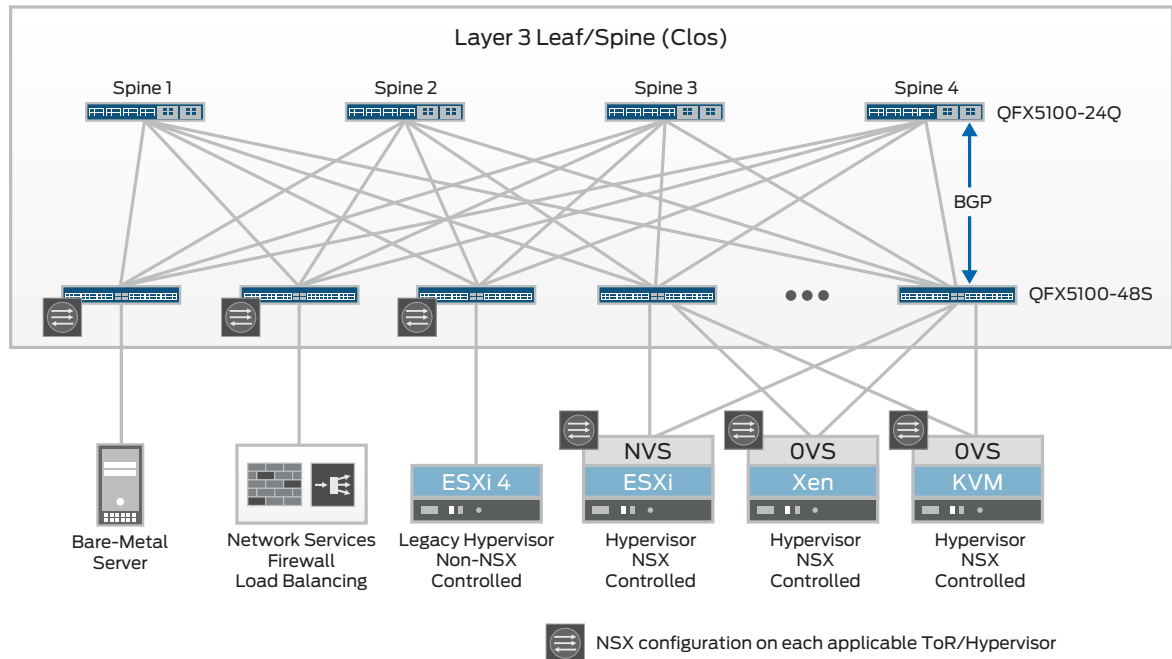

Figure 21: Juniper L3 IP Clos architecture

### Virtual Chassis Fabric Switching Architecture

The QFX5100 supports Juniper Networks' unique and highly resilient Virtual Chassis Fabric technology, which enables up to 32 interconnected switches (in a spine/leaf topology) to be managed and operated as a single, logical device with a single IP address.

A Virtual Chassis Fabric architecture enables high-performance and low-latency data center deployments while helping customers separate physical topology from logical groupings of endpoints and, as a result, provides efficient resource utilization and single L2 network domain. One Virtual Chassis Fabric pod can comprise up to 32 QFX5100 switches, with from two to eight QFX5100 switches in the spine and up to 30 QFX5100 switches as leaf nodes. This architecture provides any-rack-to-any-rack deterministic throughput and less than 2 microseconds of latency, while significantly simplifying network operations through a single point of management.

A single Virtual Chassis Fabric pod can scale to more than 1,500 10GbE servers, and multiple pods can be connected to each other using technologies such as E-VPN to achieve a much higher scale (say, a 32-pod Virtual Chassis Fabric enabling 48,000+ server ports).

Virtual Chassis Fabric technologies support both L2 multipathing and L3 ECMP paths (16-way load balancing on all active/active links within the same network fabric) while dramatically reducing the number of user configured protocols. This eliminates the need to run protocols such as Virtual Router Redundancy Protocol (VRRP) for L3 gateway load balancing and complex multicast protocols to set up replication trees. VM Mobility/vMotion and other data center use cases and applications are seamlessly supported using Virtual Chassis Fabric architectures, while also supporting NSX network virtualization/overlay technologies such as VXLAN within and across the pods.

Virtual Chassis Fabric provides the following benefits:

- **Latency:** Virtual Chassis Fabric provides predictable low latency because it uses a fabric architecture that ensures each device is one or two hops away from every other device in the fabric. The algorithm that makes traffic forwarding decisions in a Virtual Chassis Fabric contains the built-in intelligence to forward traffic by using the optimum available path to the destination, further ensuring predictable low latency for traffic traversing the Virtual Chassis Fabric.
- **Resiliency:** The Virtual Chassis Fabric architecture provides a resilient framework because traffic has multiple paths across the fabric. Traffic is, therefore, easily diverted within the fabric when a device or link fails. Multihoming of servers, storage, and other devices is also supported.
- **Flexibility:** You can easily expand the size of your Virtual Chassis Fabric by adding devices to the fabric as your networking needs grow. Virtual Chassis Fabric enables storage convergence and supports FCoE, iSCSI, NAS (NFS/CIFS), as well as a legacy Fibre Channel (FC) network (using an external QFX3500 Switch gateway). VM mobility and other applications are supported using Virtual Chassis Fabric.
- **Manageability:** Virtual Chassis Fabric provides multiple features that simplify configuration and management. Virtual Chassis Fabric, for instance, has an auto-provisioning feature that enables you to plug-and-play devices into the fabric after minimal initial configuration. All devices (up to 32) in a Virtual Chassis Fabric pod act as a single switch and enable a single point of management.

Bare-metal and virtualized servers as well as other data center resources (storage, network appliances, etc.) can be dual-homed or multihomed (16-way) to the Virtual Chassis Fabric nodes to achieve high throughput as well as better resiliency.

The L2 NSX gateway feature (hardware VTEP) is created just once for the whole Virtual Chassis Fabric pod (single management domain) and will exist on all nodes. The interfaces on the leaf switches connected to the bare-metal servers, physical appliances, or legacy hypervisors are managed by the NSX controller. Virtual Chassis Fabric enables a plug-and-play architecture and hence no VTEP configuration changes are required when adding/removing nodes from the Virtual Chassis Fabric pod. In a multihoming scenario, as illustrated in Figure 22, a bare-metal server is connected to Leaf 1 and Leaf 2, both of which are part of the same Virtual Chassis Fabric domain and act as line cards in a single chassis. If Leaf 1 fails, the bare-metal servers detect the uplink failure and use the uplink to Leaf 2 for all traffic.

Another related option is Juniper Virtual Chassis technology that typically consists of two switches (in data center access/top of rack) paired as a “Virtual Chassis” that are managed and operated as a single, logical device with a single IP address while enabling chassis-level redundancy.

The following diagram illustrates a single Virtual Chassis Fabric pod architecture comprised of four spine nodes (at least one being active, and others in standby/Routing Engine eligible mode), and 28 leaf nodes for a total of 32 nodes. As noted earlier, VTEP configuration is only done once per Virtual Chassis Fabric pod instead of doing it separately on each of the 32 nodes.

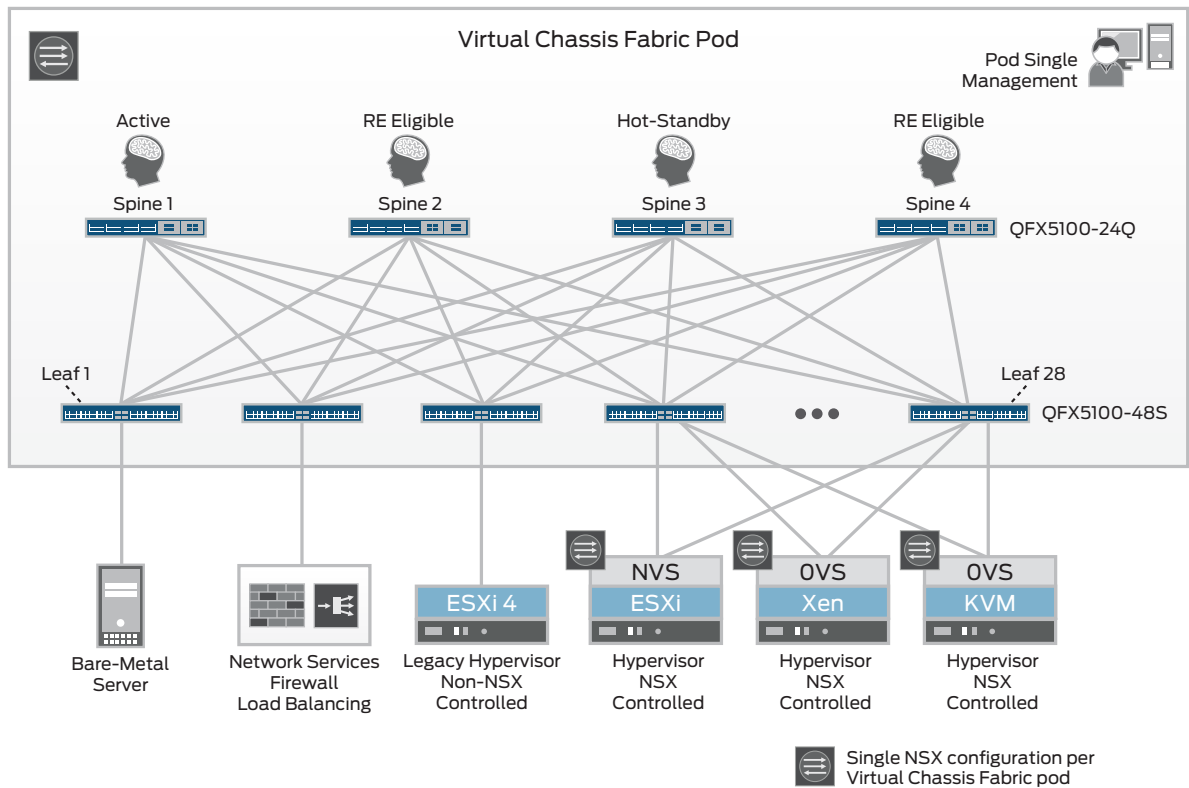

Figure 22: Juniper Virtual Chassis Fabric

## VMware NSX Integration with Juniper vSRX Firewall

The VMware NSX network virtualization platform is security oriented. The NSX Distributed Firewall (DFW) on all ESXi hosts provides a set of kernel-based L2 through L4 stateful firewall features inside the ESXi hypervisor to deliver segmentation within each virtual network.

VMware NSX, however, does not provide advanced L4 through L7 security services, which are critical to provide complete protection in an SDDC environment. Those environments that require advanced, application-level network security capabilities can leverage VMware NSX to distribute, enable, and enforce advanced network security services in a virtualized network context.

Juniper’s vSRX Virtual Firewall can be added as a complement to the VMware NSX environment. The vSRX is managed by Juniper’s Junos Space Security Director and VMware NSX Manager, delivering a complete and integrated virtual security solution for any SDDC environment. The vSRX provides advanced security services, including intrusion detection and prevention (IDP), as well as application control and visibility services through AppSecure.

VMware’s DFW implements a stateful traffic steering mechanism that identifies what traffic should be sent to the vSRX VM. Protected VMs and the security service vSRX VM run on the same physical ESXi host. Figure 23 shows the high-level integration workflow, detailed below.

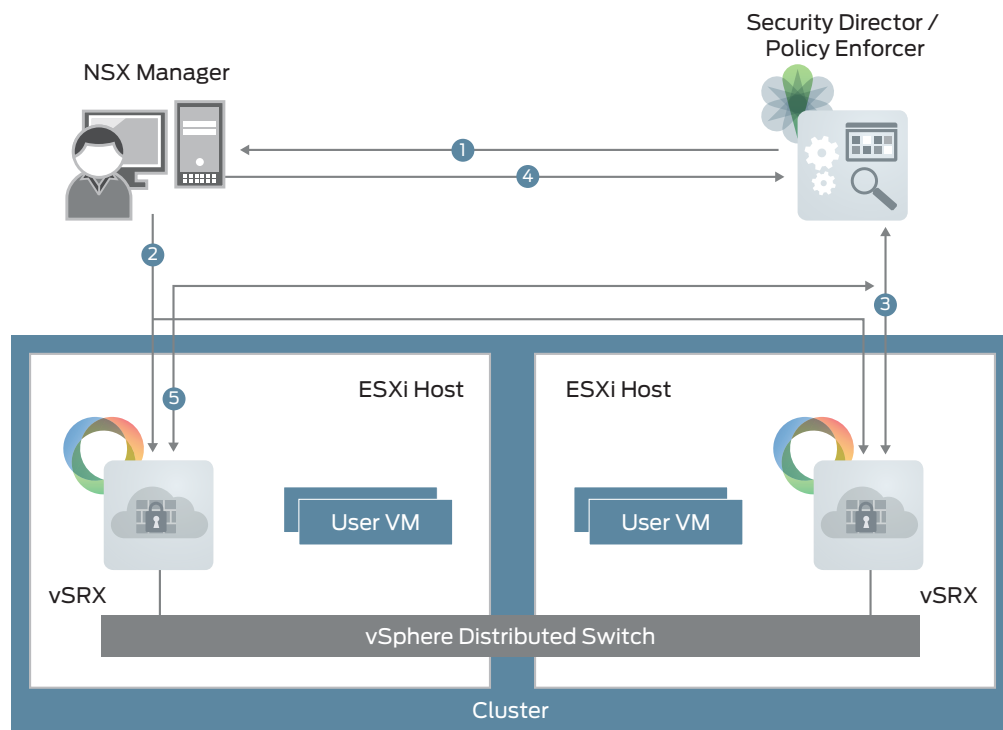

Figure 23: vSRX, Security Director, and VMware NSX Integration Workflow

1. Junos Space Security Director initiates communication with the NSX Manager, discovering, registering, and adding the NSX Manager as a device in its database. The NSX Manager, along with its inventory of shared objects (such as security groups) and addresses, are synchronized with Security Director.
2. The NSX Manager deploys the registered vSRX instance as a Juniper security service for each ESXi host in a vSphere cluster. Whenever an ESXi host is added to a vSphere cluster, NSX Manager creates a vSRX agent VM in the new ESXi host.
3. Security Director pushes the initial boot configurations and Junos OS configuration policies to each vSRX agent VM to support the NSX security group. Security Director is aware of the NSX security groups and corresponding address groups, and all deployed vSRX agent VMs are automatically discovered (one per ESXi host).  
Security policies redirect relevant network traffic originating from the VMs in specific ESXi host security groups within a vSphere cluster to the Juniper security service vSRX agent VM in each ESXi host for further analysis.
4. The vCenter Server and the NSX Manager continue to send real-time updates on changes in the virtual environment to Security Director.
5. Security Director dynamically synchronizes the object database to all vSRX agent VMs deployed in ESXi clusters. Security groups discovered by NSX Manager are mapped to a dynamic address group (DAG) in Security Director, which manages the firewall policies on the vSRX agent VMs. Using Security Director, users create advanced security service policies (such as an application firewall policy or an IPS policy) and push those policies to each vSRX agent VM in an ESXi host.

## Integrated Network Management and Automation

It's important to have a unified view of physical and virtual assets in SDDC. Traditional network solutions treat physical/underlay networks separate from virtual/overlay networks, creating a disconnect between the networks and a causing lack of visibility for the administrator. How do you know where a VM is, or has been, at any given time? How do you know which physical switches are participating in a particular virtual network?

Juniper achieves complete integration between physical and virtual networks through Junos Space Network Director, which integrates with VMware vCenter and VMware NSX controller (see Figure 24).



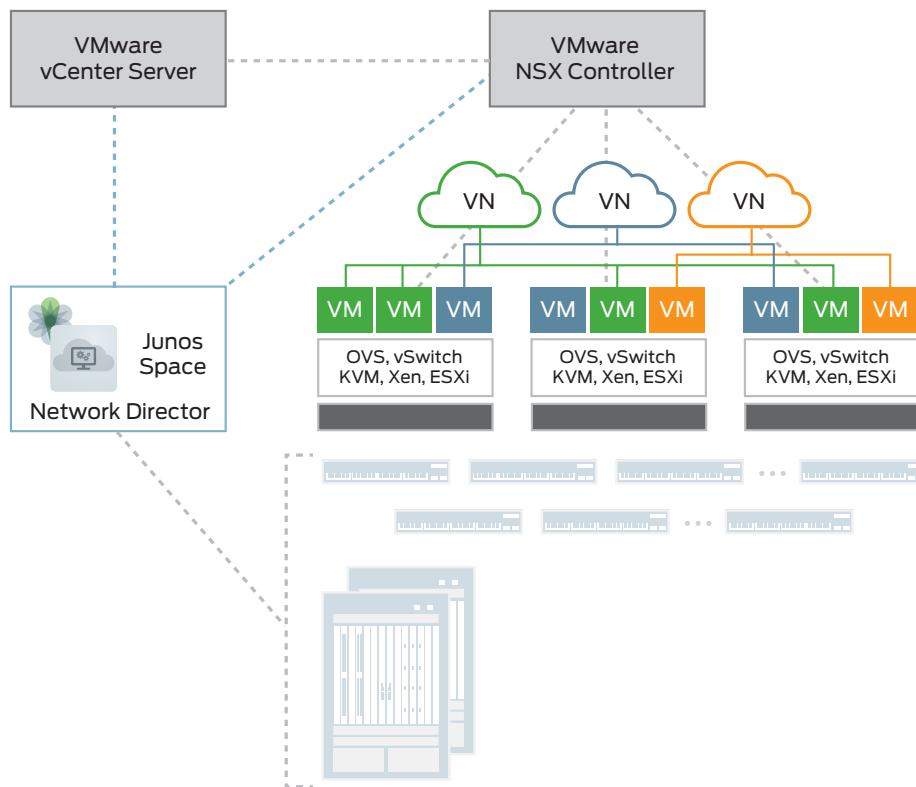

Figure 24: Network Director’s integration with VMware vCenter Server and NSX controller

### Network Director Integration with VMware vCenter

Network Director obtains all VMware context and information through its integration with VMware vCenter. Logging in to VMware vCenter and clicking on a VM reveals a Network Director tab that shows which physical switch the VM is plugged into, simplifying troubleshooting.

During VM migration, a VMware Distributed Resource Scheduler (DRS) event, or a manual move, Network Director is instantly notified and ensures that the physical networking equipment has the proper VLAN configuration to support the incoming VM. There is no need to worry about whether the physical network is configured to support virtual workloads; the Juniper-VMware integration makes takes care of that.

### Network Director Integration with VMware NSX

Network Director is integrated with VMware NSX to provide physical/underlay to virtual/overlay correlation, as shown in Figure 25. Users can easily see which physical switches host which virtual networks; which VMs are connected to what virtual and physical networks; and map all the different virtual tunnel end-points (VTEPs) across hypervisors and physical switches.

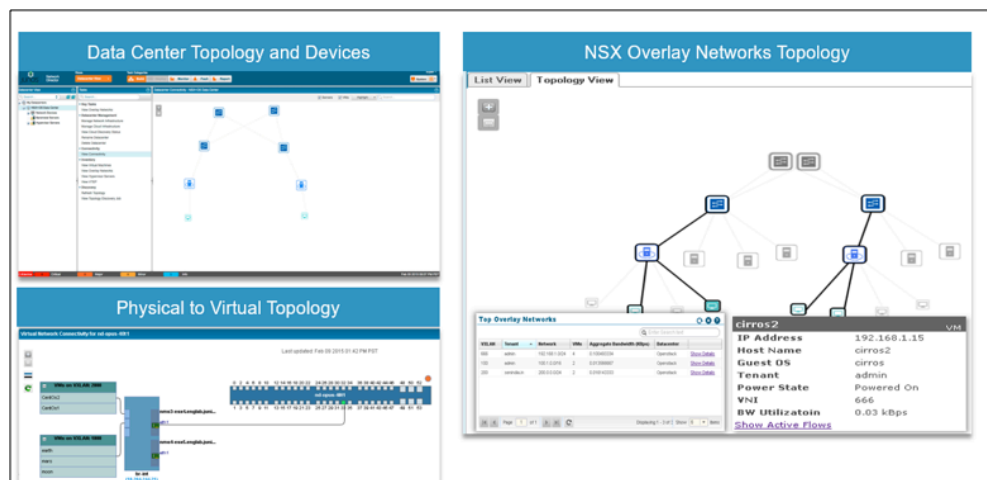

Figure 25: Overlay and underlay visibility in Junos Space Network Director

## Juniper Content Management Packs for VMware vRealize

From VMware vRealize Operations, users can easily determine physical and virtual network health, traffic utilization, and errors. From VMware vRealize Log Insight, it's possible to view security logs for SRX Series physical and vSRX virtual firewalls. Juniper offers two VMware-certified content plug-ins:

VMware-certified vRealize Operations (vROps) plug-in offers:

- Infrastructure and network activity dashboards
- VM-to-network fabric and/or VM-to-switch drill down

vRealize Log Insight plug-in offers:

- Single logging overview for VMware admins
- Network and security activity dashboards
- Log history charts and tables
- Logs pushed from SRX Series and vSRX firewalls
- Monitoring and analytics of security logs for detailed error remediation

## Conclusion

Virtual networks created through NSX allow enterprises to rapidly deploy networking and security for any application by enabling the fundamental abstraction of networks from networking hardware.

Juniper Networks leverages the NSX distributed service framework and SDK to integrate with the NSX platform and provide Layer 2 gateway services that allow the virtual network to be bridged to any physical network environment. This integration provides a unified user experience and the ability to seamlessly work with any cloud management platform such as OpenStack.

Whether providing connectivity between the virtual network and physical hosts, between remote sites, or between external networks, Juniper delivers flexible solutions for VMware NSX environments, providing seamless connectivity between physical and virtual networks and network services throughout the data center. This combined Juniper-VMware offering optimizes and secures applications and increases data center agility by delivering:

- Advanced L4-L7 firewall protection with vSRX for east-west data center traffic
- Flexible workload placement and mobility
- Single pane-of-glass management for configuring and programming virtual-to-physical network connectivity
- Operational simplicity through the programmatic connection of VXLAN tunnels to VLANs in the physical network
- Highly resilient underlay architecture based on Juniper Networks Virtual Chassis Fabric or L3 Clos architecture combined with a flexible overlay architecture from NSX
- Choice of deploying NSX L2 gateway services at various tiers of the data center network using Juniper Networks VMware-certified QFX5100 switches, EX9200 switches, and MX Series routers
- Strong degree of multitenancy and traffic separation for each tenant in Layer 2

## About Juniper Networks

Juniper Networks challenges the status quo with products, solutions and services that transform the economics of networking. Our team co-innovates with customers and partners to deliver automated, scalable and secure networks with agility, performance and value. Additional information can be found at [Juniper Networks](#) or connect with Juniper on [Twitter](#) and [Facebook](#).

### Corporate and Sales Headquarters

Juniper Networks, Inc.  
1133 Innovation Way  
Sunnyvale, CA 94089 USA  
Phone: 888.JUNIPER (888.586.4737)  
or +1.408.745.2000  
Fax: +1.408.745.2100  
[www.juniper.net](http://www.juniper.net)

### APAC and EMEA Headquarters

Juniper Networks International B.V.  
Boeing Avenue 240  
1119 PZ Schiphol-Rijk  
Amsterdam, The Netherlands  
Phone: +31.0.207.125.700  
Fax: +31.0.207.125.701

Copyright 2017 Juniper Networks, Inc. All rights reserved. Juniper Networks, the Juniper Networks logo, Juniper, and Junos are registered trademarks of Juniper Networks, Inc. in the United States and other countries. All other trademarks, service marks, registered marks, or registered service marks are the property of their respective owners. Juniper Networks assumes no responsibility for any inaccuracies in this document. Juniper Networks reserves the right to change, modify, transfer, or otherwise revise this publication without notice.

