

# JUNIPER NETWORKS AND NETAPP ENABLE BUSINESS CONTINUITY AND GLOBAL DATA AVAILABILITY

## Enable the Deployment of SnapMirror over the Existing WAN

### Challenge

Global data availability and business continuity planning are driving the need for efficient data backup and replication strategies. WAN capacity and cost limitations can hinder application performance, including data replication processes. This problem is particularly acute for highly distributed or global companies.

### Solution

By deploying data replication from NetApp in conjunction with a WAN optimization solution from Juniper Networks, companies can enable new applications and global data availability but still contain costs.

### Benefits

Together, NetApp and Juniper Networks enable organizations to deliver high data availability and more consistent application performance while ensuring business continuity and avoiding costly purchases of additional WAN bandwidth or complex WAN rollouts.

Organizations are embracing data center consolidation to improve operational efficiency, improve disaster-recovery preparedness, and consistently adhere to regulatory requirements. As servers are centralized to provide reliable, efficient access to applications and data, the market for network-attached storage (NAS) is exploding.

Effectively protecting and managing data in branch offices is an ongoing IT challenge. By more frequently and more efficiently replicating data, IT departments can deliver higher data availability as well as comply with government regulations for retaining electronic records. As business users increasingly access critical information remotely, the unintended impact is a greater reliance on WAN services. Since network expenses already account for 28 to 40 percent of IT budgets, according to Nemertes Research, increasing WAN capacity is not usually an option.

### The Challenge

Global data availability tops many enterprises' IT agendas, with business resilience and regulatory compliance for electronic record retention now imperative. As IT organizations optimize operations by centralizing key business applications and consolidating servers, they have the opportunity to increase data availability and security as well as gain control over application data residing in remote offices.

Global data availability and business continuity planning are driving the need for efficient data backup and replication strategies. With replication, companies can guarantee that data is readily available not only at headquarters but also in remote locations. Many companies struggle to ensure data backup, accessibility and recovery for remote offices. A lack of skilled IT support in remote locations adds yet another layer of complexity. This problem is particularly acute for highly distributed or global companies.

### The Juniper Networks®/NetApp SnapMirror Solution

To meet their data replication needs, many companies have turned to NetApp, which offers a comprehensive solution for remote-office data protection that simplifies information management operations, enhances data security and availability, and delivers rapid backup, restore and recovery.

To ensure high data availability and recovery, NetApp's SnapMirror® software provides two-way data replication to one or more network file servers, providing an efficient way to distribute data to remote locations and provide data protection and recovery in the event of a disaster. SnapMirror continually updates mirrored data, keeping it current and available. SnapMirror can also be configured to replicate only a subset of data, significantly reducing network bandwidth requirements.

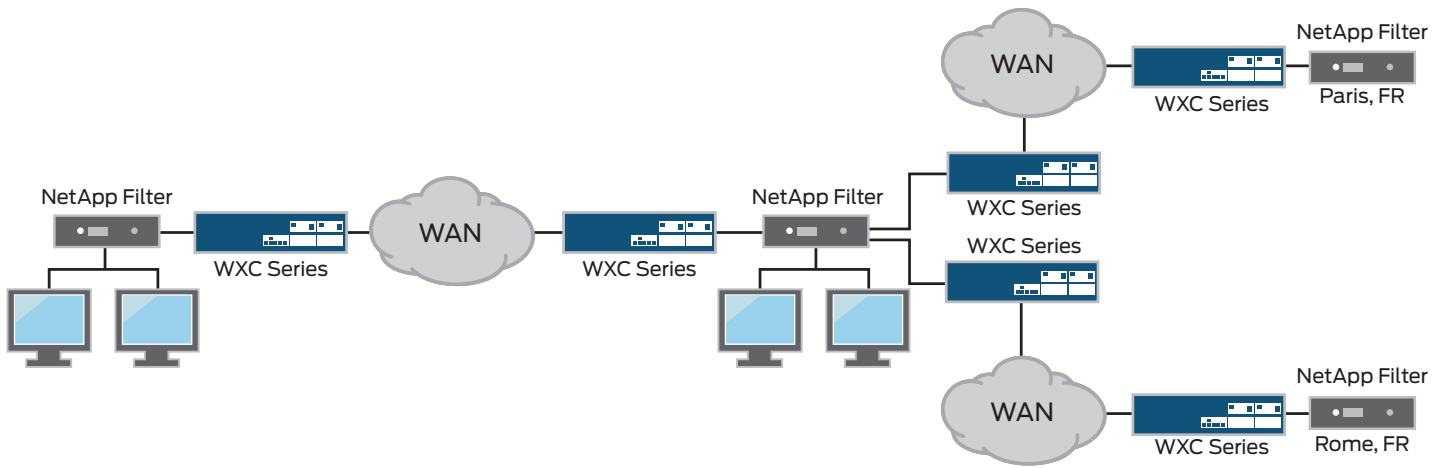

Figure 1: Juniper Networks/NetApp Deployment

For distributed networks, WAN capacity often limits overall application performance, including data replication processes. IT organizations suffer from conflicting objectives – they need to both deploy new applications and ensure global data availability but still contain costs. With network expenses accounting for 28 percent to 40 percent of IT budgets, according to Nemertes Research, increasing WAN capacity is typically not an option. By deploying replication in conjunction with a WAN optimization solution from Juniper Networks, companies get the best of both worlds—new applications and global data availability with cost savings. Juniper Networks WAN optimization platforms—part of a larger family of application acceleration platforms—instantly increase WAN capacity as much as 10-fold, eliminating the expense of WAN upgrades, and limiting the impact that WAN latency has on applications such as data replication.

Together, NetApp and Juniper Networks enable organizations to deliver high data availability and more consistent application performance while ensuring business continuity and avoiding costly purchases of additional WAN bandwidth or complex WAN rollouts.

## Features and Benefits

WAN optimization provides for speedy replications and improved application response times. The most effective approach demands that several business and technical requirements are met, including:

### Increased WAN Performance of Data Replication

Compression is a significant contributor to optimizing performance over WAN links. Fast replication times are essential for completing data backup in a reasonable timeframe and for getting backup sites up and running quickly in a disaster-recovery scenario. IT is under increasing pressure to minimize backup windows to accommodate ever-increasing data volumes and to reduce backup error rates and “restarts.”

### Ensured Bandwidth Availability for Critical Enterprise Applications

There’s no point in optimizing WAN links if they are immediately clogged with peer-to-peer traffic or other non-essential communications. With quality of service (QoS), IT can prioritize application traffic and allocate the WAN bandwidth so that key applications perform consistently without being impacted by sudden “bursty” replication and backup traffic. Time-sensitive applications like VoIP, for example, need to run smoothly even when they’re sharing the WAN link with backup applications. Also, as businesses operate more globally, the notion of a “quiet” time on the WAN has disappeared, so IT needs to run the data replication/backup applications continuously to ensure data integrity and complete backups.

### Accelerated Applications

Optimizing TCP/IP flows allows for more frequent replications with optimal application performance across the WAN. Fast setup of TCP sessions, dynamically adjusting TCP window size for older systems, substituting a more reliable and bandwidth-efficient transport, and streamlining inherently inefficient protocols can significantly reduce the amount of time it takes to complete WAN transmissions and improve application performance.

### Simplified Initial Full-Volume Transfers

Enabling data replication to take place over the WAN, rather than requiring the use of tapes, can dramatically reduce the time needed to migrate a large database from one location to another. Using the WAN for this transfer also eliminates the problems presented by having incompatible tape-based systems in two locations.

### Monitored WAN Performance

Real-time WAN monitoring and reporting is essential so that IT can gain instant visibility into network performance. Reports of top talkers and the ability to capture packets can assist in understanding the root cause of problems and addressing them in a timely manner.

## Simplified Deployment

With today's focus on operational efficiency, it's a given that WAN optimization and application acceleration platforms must be easy to configure and deploy. Remote-office locations often lack onsite IT support, so deploying WAN optimization cannot require changes to existing applications, networks, routers or WAN interfaces. WAN optimization devices must also work transparently with IPsec VPNs and MPLS.

## Flexible, Reliable Deployment

WAN optimization devices should offer multiple deployment options. Some sites, for example, have a link between LAN backbone equipment and the WAN router, while other locations use a collapsed backbone, with one device supporting both the backbone connections and the WAN interfaces. WAN optimization platforms must be able to operate in either scenario. They also need to support the range of data replication models, including one-to-one (1:1) and cascading deployments.

## Solution Components

Juniper Networks WXC Series Application Acceleration Platforms instantly increase WAN capacity, enabling IT to leverage their existing WAN infrastructure, prioritize network traffic and accelerate applications with their SnapMirror deployment.

The WXC Series platform is based on the WX Framework, which integrates a comprehensive and interdependent set of technologies to accelerate application performance over wide area links, delivering the ideal solution for improving and streamlining data replication.

The WX Framework defines specific attributes that a WAN optimization and application acceleration platform must have to overcome the bandwidth, latency, congestion and manageability issues that impede application performance over the WAN. Each element of the WX Framework addresses a specific challenge that prevents applications from running efficiently over the WAN. These are organized into four categories: compression and caching, acceleration, application control and visibility.

The compression and caching component of the WX Framework includes: Molecular Sequence Reduction (MSR) compression, which frees up WAN capacity by eliminating repeated data patterns; and Network Sequence Caching, which uses hard disks to store and recognize large repeated patterns, even if they were sent days or weeks earlier.

The acceleration component includes Packet Flow Acceleration (PFA) techniques, which combat the effects of latency on the TCP protocol, and Application Flow Acceleration (AppFlow) technology, which provides protocol-specific acceleration for applications such as Exchange, Microsoft file services, and Web.

The application control segment includes Policy-Based Multipath (Multipath) optimization technology, which allows IT to direct application flows to a specific WAN link when multiple links are available. It also includes QoS and bandwidth-

management tools for prioritizing critical application traffic and ensuring bandwidth availability.

Finally, the visibility components of the WX Framework include WebView device management for configuring and managing individual WXC Series platforms, and Juniper Networks WX Central Management System software for gaining visibility into and centralized control over platforms distributed throughout an organization.

These technologies work together seamlessly and transparently to meet the challenges associated with data replication over the WAN.

## Instantly Increase WAN Capacity to Accelerate Data Replication

With the WXC Series platform, IT can instantly increase existing network link capacity up to 10 times. The MSR and sequence caching technologies reduce the amount of traffic traversing the WAN link. MSR compression identifies variable-sized, repeating patterns in the data stream across multiple packets, applications or sessions and replaces those patterns with a label, reducing the traffic flow. The labels and their associated data patterns are stored in memory in dictionaries in the WXC Series devices on both ends of the WAN link.

Sequence caching is similar to MSR compression in its use of labels, but with sequence caching—available only with the WXC Series Application Acceleration Platforms—the stored pattern sequences reside on hard disks, increasing the size of the patterns stored as well as the time between repeated patterns. The combination of both MSR and sequence caching technologies provides optimum data reduction, and because up to 90 percent of network traffic is repetitive, eliminating this data redundancy generates significant efficiencies in WAN transmissions.

By pairing the WXC Series devices with SnapMirror, IT can reduce their SnapMirror data transmissions by up to 75 percent, yielding a four-fold increase in WAN capacity. As a result, scheduled SnapMirror replications complete within the allotted time, and disaster-recovery operations are improved, with backup sites up and running much faster.

## Ensure Bandwidth Availability for Critical Enterprise Applications

The bandwidth-management tools defined by the WX Framework, including QoS and bandwidth allocation, enable IT to prioritize applications across the WAN and allocate bandwidth among applications. With these tools, IT can readily define minimum and/or maximum throughput levels for the data-replication processes as well as other business applications. So when SnapMirror traffic crosses a WAN link with other high-priority applications such as VoIP, these tools ensure that the more sensitive and “bursty” phone traffic is not impacted by backup traffic. Also, IT can set data replication to run continuously, allocated to a small percentage of the WAN link to not overrun other business applications, so that backups can complete and data integrity remains high.

## Accelerate Applications

The WXC Series platform dramatically improves application response times by optimizing TCP/IP flows as well as higher-layer protocols for specific applications. The innovative PFA techniques minimize the impact of WAN latency, enabling TCP/IP traffic to flow faster and optimizing frequent replications. PFA operates transparently to applications and network equipment, simplifying its implementation. PFA techniques can also dynamically adjust the window size of older TCP clients, sending 64 KB window sizes between the WXC Series devices, even though the sender or receiver may support only 16 KB. Local buffering in the WXC Series platform ensures that TCP hosts are not overrun.

A more recent PFA addition, Active Flow Pipelining, uses its own reliable transport protocol in lieu of TCP on high-latency links to utilize more of the WAN link, and to accelerate application response times by eliminating the need to wait for acknowledgements on TCP. These PFA techniques allow IT to maximize utilization across the WAN, transparent to applications and network equipment.

## Perform Real-Time Backups While Systems are Running

For higher-layer support, the AppFlow technology accelerates applications that are constrained by their own protocol behavior, specifically Microsoft Exchange, which uses the Messaging Application Programming Interface (MAPI), Microsoft file services, which uses the Common Internet File System (CIFS) protocol, and Web-based applications using HTTP. For MAPI and CIFS, which break files into multiple blocks that must be individually sent, received and acknowledged before the next block can be forwarded, the AppFlow technique pipelines the data, simultaneously sending as many data blocks as needed to fill the available WAN capacity. The process eliminates the hundreds or even thousands of round-trip times (RTTs) required to complete a single transmission, enabling messages and files to be downloaded at LAN speeds.

For Web traffic, the AppFlow technique enables WXC Series devices to learn and cache objects associated with URLs that are typically sent one at a time when a Web page is requested. WXC Series platform confirms the freshness of each object or pre-fetch them when new or updated versions are available, in advance of the client's request. This allows browsers to display Web pages much faster.

## Simplify Initial Full-Volume Transfers

The WAN capacity increases from MSR and sequence caching technologies, the QoS capabilities, and the PFA and AppFlow techniques make it possible for IT to use the WAN link to transfer very large databases. Traditionally, IT has relied on sending tapes

around to initialize a replicated data store, since the time window needed to perform this task over a non-optimized WAN would be prohibitive. However, enterprises sometimes have incompatible tape systems in different locations, and they would like the convenience of transferring this data over the WAN provided they could avoid impacting business operations. The WXC Series platform enables this option.

## Monitor WAN Performance

Powerful real-time WAN monitoring and reporting capabilities available with the WXC Series platform provide IT with packet capture, top talker, and other WAN and application statistics critical for maximizing wide area resources. An intuitive GUI provides IT managers with instant visibility into network performance, and the WXC Series devices also support exporting data to third-party tools. As a result, IT could, for example, export NetFlow statistics to any NetFlow platform (such as Concord or Micromuse) to perform traffic analysis.

## Ensure Easy Deployment

The WXC Series Application Acceleration Platforms are easy to install and configure. Installation of hub devices is typically a 10-minute process, and IT can automate deployment in branch offices that have no local IT staff. IT simply defines a configuration in the WX CMS software for the remote locations; upon booting up, remote devices will automatically request a temporary address, look up the central WX CMS server, download the configuration and begin operation.

In addition to supporting this automated deployment, the WXC Series platform also operates transparently to existing applications, networks, routers and WAN interfaces. The platform also works transparently with IPsec VPNs, MPLS and firewalls.

## Ensure Flexible, Reliable Deployment

The WXC Series devices are rack-mountable network appliances that interface to the network as two-port LAN switches, sitting inline between a LAN backbone switch and a WAN router or off-path attached to a WAN router serving as a collapsed backbone. They support 10/100/1000 Ethernet interfaces and are installed behind external firewalls and encryption devices, processing corporate data before it's sent to WAN transmission devices.

The platform is also highly reliable and integrate seamlessly with High Availability (HA) environments and load-balanced networks. In the event of a traffic overload, the the platform passes through the excess traffic; in the event of a failure, they automatically switch to pass-through mode, allowing all traffic to flow through the device and across the WAN.

## Summary – NetApp and Juniper Networks Form a Powerful Partnership

NetApp provides businesses with the data-replication features essential to data center consolidation and disaster-recovery architectures. Juniper Networks enables the deployment of SnapMirror and other backup and disaster-recovery solutions over the existing WAN without expensive and time-consuming network upgrades. With the WXC Series Application Acceleration Platforms from Juniper Networks, deployed in conjunction with SnapMirror, enterprises can deploy more filers, replicate their files more often with SnapMirror, and have backups occur within the designated timeframes—all while leveraging their existing WAN infrastructure and capacity. Faster, more reliable backups, improved application support, and optimized WAN throughput—NetApp and Juniper Networks deliver it all.

### Next Steps

For more information on how a WAN optimization solution from Juniper Networks can enable SnapMirror deployments on a global basis, please visit [www.juniper.net/products\\_and\\_services/application\\_acceleration/](http://www.juniper.net/products_and_services/application_acceleration/).

## About NetApp

NetApp creates innovative storage and data management solutions that accelerate business breakthroughs and deliver outstanding cost efficiency. Discover NetApp's passion for helping companies around the world go further, faster at [www.netapp.com](http://www.netapp.com).

## About Juniper Networks

Juniper Networks, Inc. is the leader in high-performance networking. Juniper offers a high-performance network infrastructure that creates a responsive and trusted environment for accelerating the deployment of services and applications over a single network. This fuels high-performance businesses. Additional information can be found at [www.juniper.net](http://www.juniper.net).

---

### Corporate and Sales Headquarters

Juniper Networks, Inc.  
1194 North Mathilda Avenue  
Sunnyvale, CA 94089 USA  
Phone: 888.JUNIPER (888.586.4737)  
or 408.745.2000  
Fax: 408.745.2100  
[www.juniper.net](http://www.juniper.net)

### APAC Headquarters

Juniper Networks (Hong Kong)  
26/F, Cityplaza One  
1111 King's Road  
Taikoo Shing, Hong Kong  
Phone: 852.2332.3636  
Fax: 852.2574.7803

### EMEA Headquarters

Juniper Networks Ireland  
Airside Business Park  
Swords, County Dublin, Ireland  
Phone: 35.31.8903.600  
EMEA Sales: 00800.4586.4737  
Fax: 35.31.8903.601

To purchase Juniper Networks solutions, please contact your Juniper Networks representative at 1-866-298-6428 or authorized reseller.

Copyright 2010 Juniper Networks, Inc. All rights reserved. Juniper Networks, the Juniper Networks logo, Junos, NetScreen, and ScreenOS are registered trademarks of Juniper Networks, Inc. in the United States and other countries. All other trademarks, service marks, registered marks, or registered service marks are the property of their respective owners. Juniper Networks assumes no responsibility for any inaccuracies in this document. Juniper Networks reserves the right to change, modify, transfer, or otherwise revise this publication without notice.