

Chapter 31

Monitoring the SSB

You monitor the M20 router System and Switch Board (SSB) to ensure that it provides allocation of incoming data packets throughout shared memory on the Flexible PIC Concentrators (FPCs), transfers outgoing data cells to the FPCs for packet reassembly, performs route lookups using the forwarding table, monitors system components for failure and alarm conditions, and monitors FPC operation and reset. (See Table 94.)

Table 94: Checklist for Monitoring the SSB

Monitor SSB Tasks	Command or Action
Understanding the SSB on page 406	
Monitoring the SSB Status on page 408	
1. Display the SSB Environmental Status on page 408	show chassis environment
2. Display the SSB Detailed Status on page 409	show chassis ssb
3. Check the SSB LEDs on page 409	Check the LEDs on the SCB faceplate.
Checking for SSB Alarms on page 410	
1. Display SSB Error Messages in the System Log File on page 410	show log messages
2. Display SSB Error Messages in the Chassis Daemon Log File on page 411	show log chassisd match ssb
Verifying SSB Failure on page 411	
1. Check the SSB Connection on page 411	Check the thumbscrews on the left and right sides of the SSB.
2. Perform a Swap Test on the SSB on page 412	1. Take the SSB offline. 2. Remove the SSB. 3. Replace the SSB with one that you know works.
Getting SSB Hardware Information on page 413	
1. Display the SSB Hardware Information on page 413	show chassis hardware
2. Locate the SSB Serial Number ID Label on page 413	Look for the SSB serial number label located on the top of the SSB adjacent to the SDRAM memory bank.
3. Display the SSB Firmware Version on page 414	show chassis firmware
Replacing the SSB on page 414	See “Return the Failed Component” on page 86, or follow the procedure in the <i>M20 Internet Router Hardware Guide</i> .

Understanding the SSB

Purpose Inspect the SSB to ensure that it provides allocation of incoming data packets throughout shared memory on the FPCs, transfers outgoing data cells to the FPCs for packet reassembly, performs route lookups using the forwarding table, monitors system components for failure and alarm conditions, and monitors FPC operation and reset.

What Is the SSB The SSB is a component of the Packet Forwarding Engine and performs the following major functions (see Figure 164 on page 407):

Shared memory management on the FPCs—The Distributed Buffer Manager application-specific integrated circuit (ASIC) on the SSB uniformly allocates incoming data packets throughout shared memory on the FPCs.

Outgoing data cell transfer to the FPCs—A second Distributed Buffer Manager ASIC on the SSB passes data cells to the FPCs for packet reassembly when the data is ready to be transmitted.

Route lookups—The Internet Processor ASIC on the SSB performs route lookups using the forwarding table stored in synchronous SRAM (SSRAM). After performing the lookup, the Internet Processor ASIC informs the midplane of the forwarding decision, and the midplane forwards the decision to the appropriate outgoing interface.

System component monitoring—The SSB monitors other system components for failure and alarm conditions. It collects statistics from all sensors in the system and relays them to the Routing Engine, which sets the appropriate alarm. For example, if a temperature sensor exceeds the first internally defined threshold, the Routing Engine issues a “high temp” alarm. If the sensor exceeds the second threshold, the Routing Engine initiates a system shutdown.

Exception and control packet transfer—The Internet Processor ASIC passes exception packets to a microprocessor on the SSB, which processes almost all of them. The remaining packets are sent to the Routing Engine for further processing. Any errors originating in the Packet Forwarding Engine and detected by the SSB are sent to the Routing Engine using system log messages.

FPC reset control—The SSB monitors the operation of the FPCs. If it detects errors in an FPC, the SSB attempts to reset the FPC. After three unsuccessful resets, the SSB takes the FPC offline and informs the Routing Engine. Other FPCs are unaffected, and normal system operation continues.

Figure 164: SSB Component

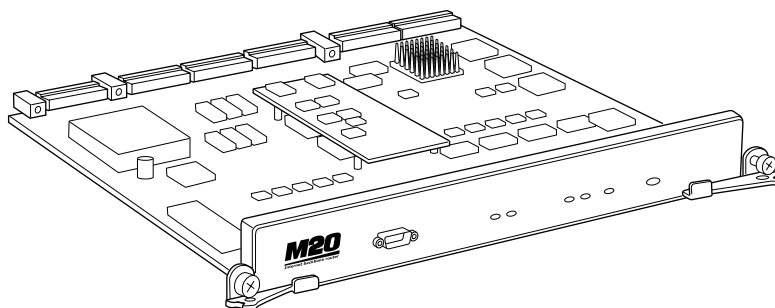

1151

You can install two SSBs in the M20 router. The SSBs occupy the two top slots of the card cage (SSB0 and SSB1), and are installed into the midplane from the front of the chassis. (See Figure 165.)

Figure 165: M20 Router SSB Location

**M20 Router
front**

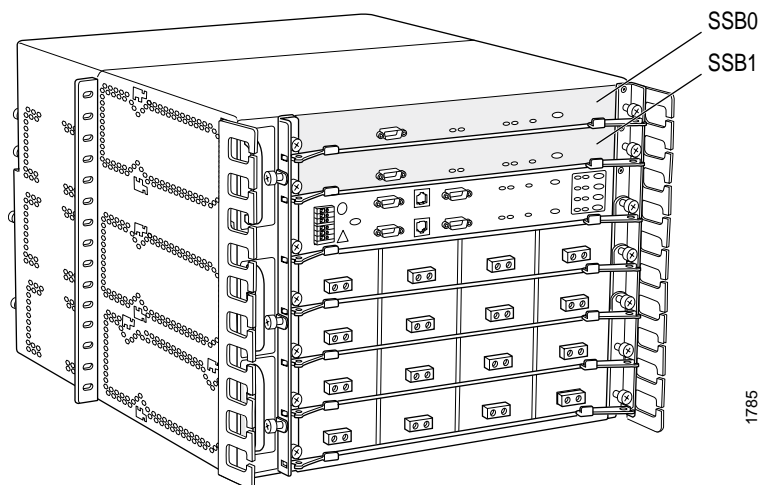

1785

The SSB houses the Internet Processor ASIC and two Distributed Buffer Manager ASICs.

The SSB is hot-pluggable. You can remove and replace it without powering down the system; however, this causes major impact to the system. While the SSB is out of the router, route lookups, system component monitoring, exception and control packet transfer, and FPC resets cannot occur.

When the SSB is removed, all packet forwarding stops immediately and the Routing Engine responds by generating alarms. When the SSB is replaced, it is rebooted by flash EEPROM.

If you have removed the Routing Engine, the SSB enters a warm shutdown mode and continues its forwarding process for a limited time using a frozen forwarding table. The time limit is determined by a timer in the SSB. If you replace the Routing Engine during the warm shutdown period, the SSB unfreezes its forwarding tables and resumes normal functioning. Otherwise, the SSB shuts down.

Monitoring the SSB Status

If the SSB fails, no information about the chassis components is available through the JUNOS software command-line interface (CLI).

Steps To Take To monitor the SSB, follow these steps:

1. Display the SSB Environmental Status on page 408
2. Display the SSB Detailed Status on page 409
3. Check the SSB LEDs on page 409

Step 1: Display the SSB Environmental Status

Action To display the SSB environmental status, use the following CLI command:

```
user@host> show chassis environment
```

Sample Output

```
user@host> show chassis environment
Class Item      Status  Measurement
Power Power Supply A  Failed
  Power Supply B    OK
Temp FPC Slot 0    OK      27 degrees C / 80 degrees F
  FPC Slot 1       OK      30 degrees C / 86 degrees F
  FPC Slot 2       OK      26 degrees C / 78 degrees F
  FPC Slot 3       OK      25 degrees C / 77 degrees F
  Power Supply A   OK      28 degrees C / 82 degrees F
  Power Supply B   OK      24 degrees C / 75 degrees F
  SSB Slot 0       OK      25 degrees C / 77 degrees F
  Backplane        OK      21 degrees C / 69 degrees F
Fans Rear Fan      OK      Spinning at normal speed
  Upper Fan        OK      Spinning at normal speed
  Middle Fan       OK      Spinning at normal speed
  Bottom Fan       OK      Spinning at normal speed
Misc Craft Interface OK
```

What It Means The command output displays the SSB status and temperature. The SSB status can be OK, Failed, or Absent.

Step 2: Display the SSB Detailed Status

Action To display more detailed SSB status information, use the following CLI command:

```
user@host> show chassis ssb
```

Sample Output

```
user@host> show chassis ssb
SSB status:
Failover:          0 time
Slot 0:
State:            Master
Temperature:      33 Centigrade
CPU utilization:   0 percent
Interrupt utilization: 0 percent
Heap utilization:  0 percent
Buffer utilization: 6 percent
DRAM:            64 Mbytes
Start time:       1999-01-15 22:05:36 UTC
Uptime:          21 hours, 21 minutes, 22 seconds
Slot 1:
State:            Backup
```

What It Means The command output displays the number of times the mastership has changed, the SSB slot number 0 or 1, and the current state of the SSB: Master, Backup, or Empty. The command output displays the temperature of the air passing by the SSB, in degrees Centigrade. It also displays the total percentage of CPU, interrupt, heap space, and buffer space being used by the SSB processor, including the total DRAM available to the SSB processor. The command output displays the time when the SSB started running and how long the SSB has been running.

Alternative Action To display the status for a particular SSB, use the following CLI command:

```
user@host> show chassis ssb slot
```

Step 3: Check the SSB LEDs

Periodically check the SSB LEDs to verify that the SSB is online or offline and the type of task it is performing.

Action To check the SSB LEDs, look on the faceplate at the front of the router (see Figure 166).

Figure 166: SSB LEDs

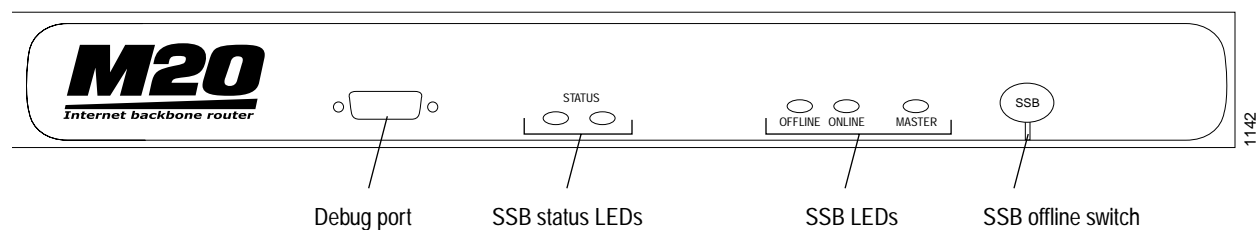

The SSB has two groups of LEDs: online/offline LEDs and status LEDs. The online/offline LEDs indicate whether the SSB is online or offline. The status LEDs indicate what type of task the SSB is performing. Table 95 describes the LED states.

Table 95: SSB LEDs

Label	Color	State	Description
OFFLINE	Amber	On steadily	SSB is offline.
ONLINE	Green	On steadily	SSB processor is running.
MASTER	Blue	On steadily	SSB is master.
STATUS (left)	Green	Blinking	SSB processor is running. Normally, the blinking is faint and becomes bright only when the SSB is processing many exceptions.
STATUS (right)	Green	Flashing	I/O interrupts are occurring.

Checking for SSB Alarms

Steps To Take To check for SSB alarms, follow these steps

1. Display SSB Error Messages in the System Log File on page 410
2. Display SSB Error Messages in the Chassis Daemon Log File on page 411

Step 1: Display SSB Error Messages in the System Log File

Periodically check the SYSLOG messages on the management console for messages sent by the SSB. During normal operation, the SSB notifies the Routing Engine of any errors it detects.

Action To display the SSB error messages in the system log file, use the following CLI command:

```
user@host> show log messages
```

Sample Output

```
user@host> show log messages
Jul 10 13:28:45 myrouter /kernel: fxp1: media DOWN 100Mb / full-duplex
Jul 10 13:28:45 myrouter /kernel: fxp1: media DOWN 10Mb / half-duplex
Jul 10 13:28:45 myrouter /kernel: fxp1: media DOWN 100Mb / full-duplex
Jul 10 13:28:45 myrouter /kernel: fxp1: link UP 100Mb / full-duplex
Jul 10 13:28:45 myrouter rpd[564]: EVENT <UpDown> fxp1.0 index 1 <Up Broadcast Multicast> address #0
0.a0.a5.12.1d.6d
Jul 10 13:28:45 myrouter mib2d[563]: SNMP_TRAP_LINK_UP: ifIndex 2, ifAdminStatus up(1), ifOperStatus up(1),
ifName fxp1
[...Output truncated...]
```

What It Means The messages system log file records the time the failure or event occurred, the severity level, a code, and a message description. You can also use the `show log messages | match ssb` command to see error messages that are generated when an SSB fails or is offline. Use this information to diagnose a problem and to let the Juniper Networks Technical Assistance Center (JTAC) know what the error messages are and the router events that occurred before and after the problem. For more information about system log messages, see the *JUNOS System Log Messages Reference*.

Step 2: Display SSB Error Messages in the Chassis Daemon Log File

Action To display the SSB error messages in the chassis daemon (`chassisd`) log file, use the following CLI command:

```
user@host> show log chassisd | match ssb
```

Sample Output

```
user@host> show log chassisd |match ssb
Jul 10 13:27:28 SSB0 is now not present
Jul 10 13:27:28 Assert reset on SSB0
Jul 10 13:27:28 Turn on ethernet loop
[...Output truncated...]
```

What It Means The `chassisd` database provides the date, time, and a component status message. The `chassisd` database is dynamic. It is initialized at router startup and is updated when components are added or removed. You can search for multiple items in the `chassisd` log file by using the `| match "item | item | item"` command. For example, `| match "ssb | kernel | tnp"` is a search for error messages for the SSB, kernel, and Trivial Networking Protocol (TNP), and indicates communication issues between the Routing Engine and the Packet Forwarding Engine components.

Verifying SSB Failure

Steps To Take To verify SSB failure, follow these steps:

1. Check the SSB Connection on page 411
2. Perform a Swap Test on the SSB on page 412

Step 1: Check the SSB Connection

If the SSB is not seated properly, it will not function.

Action To check the SSB connection, make sure that the SSB is properly seated in the slot. To seat the SSB properly, securely tighten the screws on the left and right sides of the card carrier.

Step 2: Perform a Swap Test on the SSB



CAUTION: Before performing a swap test, always check for bent pins in the midplane and check the SSB for stuck pins in the connector. Pins stuck in the component connector can damage other good slots during a swap test.

Action To perform a swap test on an SSB, follow these steps:

1. Attach an electrostatic discharge (ESD) wrist strap to your bare wrist, and connect the wrist strap to one of the two ESD points on the chassis.
 2. Locate the SSB offline switch on the front panel and press and hold the switch for 5 seconds to take the SSB offline.
-



CAUTION: If you take the SSB offline, packet forwarding will be affected.

3. Unscrew the thumbscrews on the left and right sides of the card carrier to unseat the SSB from the midplane.
 4. Flip the ends of the two extractor clips, which are adjacent to the thumbscrews, towards the outside edges of the router.
 5. Grasp both sides of the card carrier and slide the SSB about three-quarters of the way out of the router.
 6. Move one of your hands underneath the SSB to support it, and slide it completely out of the chassis.
 7. Replace the SSB with one that you know works.
 8. Grasp the front of the SSB card carrier with both hands and align the back of the card carrier with the slide guides on the chassis.
 9. Slide the SSB card carrier all the way into the card cage until it contacts the midplane.
 10. Flip the extractor clips, located on the left and right sides of the card carrier, towards each other to secure the SSB in place.
 11. Tighten the thumbscrews on the left and right sides of the card carrier to seat the SSB.
-



NOTE: To seat the SSB properly, be sure to tighten the screws securely. If the SSB is not seated properly, it will not function.

Getting SSB Hardware Information

- Steps To Take**
1. Display the SSB Hardware Information on page 413
 2. Locate the SSB Serial Number ID Label on page 413
 3. Display the SSB Firmware Version on page 414

Step 1: Display the SSB Hardware Information

Action To display the SSB hardware information, use the following CLI command:

```
user@host> show chassis hardware
```

Sample Output

```
user@host> show chassis hardware
Hardware inventory:
Item      Version Part number Serial number  Description
[...Output truncated...]
SSB slot 0  REV 01  710-001951 AD5904      Internet Processor II
SSB slot 1  N/A    N/A      N/A         backup
[...Output truncated...]
```

What It Means The command output displays the SSB version level, part number, serial number, and description.

Step 2: Locate the SSB Serial Number ID Label

Action To locate the SSB serial number ID label, look on the top of the SSB adjacent to the SDRAM memory bank. See Figure 167.

Figure 167: SSB Serial Number ID Label

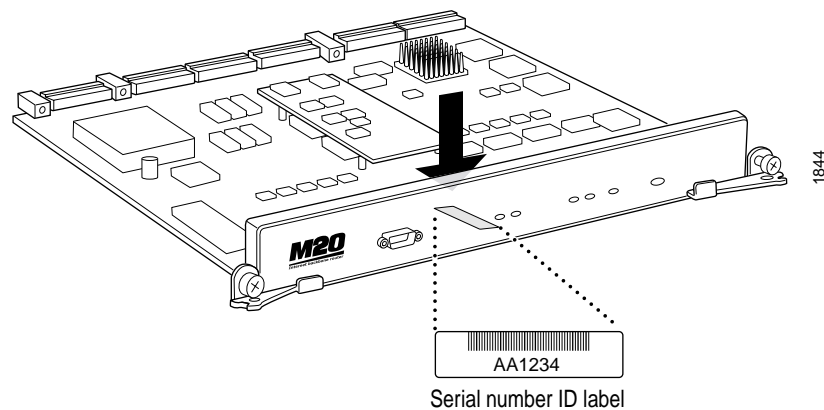

Step 3: Display the SSB Firmware Version

Action To display the version of firmware running on the SSB, use the following CLI command:

```
user@host> show chassis firmware
```

Sample Output

```
user@host> show chassis firmware
Part          Type    Version
[...Output truncated...]
SSB 0         ROM     Juniper ROM Monitor Version 4.2b1
              O/S     Version 5.4I20020626_0216_mtiwari by mtiwar
SSB 1
```

What It Means The command output displays the type and version level of the firmware running on the SSB.

Replacing the SSB

The SSB is hot-pluggable. When the SSB is removed, all packet forwarding stops immediately and the Routing Engine responds by sending alarms through the Ethernet channel to the management console. When the SSB is replaced, it is rebooted by flash EEPROM.

Action If the SSB fails, replace it as described in the *M20 Internet R outer Hardware Guide*.