

Chapter 26

Monitoring the SFMs

You monitor the Switching and Forwarding Modules (SFMs) to ensure that traffic transiting the router is handled properly. (See Table 84.)

Table 84: Checklist for Monitoring the SFMs

Monitor SFM Tasks	Command or Action
Understanding the SFMs on page 348	
Monitoring the SFM Status on page 349	
1. Display the SFM Summary Status on page 349	show chassis sfm <i>sfm-slot</i> show chassis sfm detail <i>sfm-slot</i>
2. Display the SFM LED Status at the Command Line on page 351	show chassis craft-interface
3. Check the SFM LED Status on the Faceplate on page 351	Check the SFM faceplate at the back of the M40e and M160 router chassis.
4. Display the SFM Environmental Status on page 351	show chassis environment show chassis environment sfm <i>sfm-slot</i>
Displaying SFM Alarms on page 353	
1. Display Current SFM Alarms on page 353	show chassis alarms
2. Display SFM Error Messages in the System Log File on page 353	show log messages
3. Display SFM Error Messages in the Chassis Daemon Log File on page 354	show log chassisd
Verifying SFM Failure on page 355	
1. Check the SFM Connection on page 355	Check the thumbscrews on the SFM ejector locking tabs.
2. Check the SFM Fuses on page 355	The M40e and M160 router fuses are located in a fuse box at the rear of the midplane, behind the lower rear impeller assembly.
3. Perform an SFM Swap Test on page 356	1. Take the SFM offline. 2. Replace the SFM with one that you know works. 3. Bring the SFM online. 4. Check the SFM status.
Getting SFM Hardware Information on page 357	
1. Display SFM Hardware Information on page 357	show chassis hardware

Monitor SFM Tasks	Command or Action
2. Locate the SFM Serial Number ID Label on page 357	Look on the top left of the SFM component.
Replacing the SFM on page 358	See “Return the Failed Component” on page 86, or follow the procedure in the appropriate router hardware guide.

Understanding the SFMs

Purpose Inspect the SFMs to ensure that all traffic leaving the Flexible PIC Concentrators (FPCs) is handled properly.

What Is an SFM The SFM is a control board that handles traffic transiting the router (see Figure 144). There are two SFMs on the M40e router and four SFMs on the M160 router (see Figure 145).

Figure 144: SFM Component

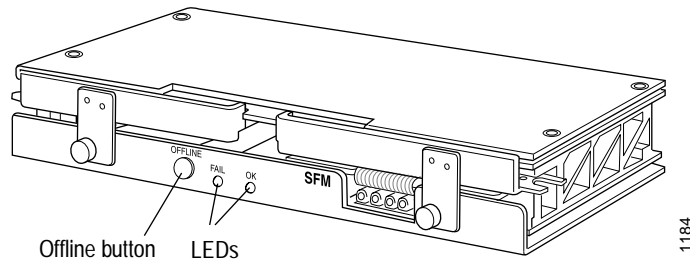

The SFMs provide route lookup, filtering, and switching. When the serial stream of bits leaves the FPC, it is directed to one of the SFMs. Each SFM effectively handles one-half or one-quarter of the traffic on each FPC. The SFMs handle a total of 160 million packets per second (Mpps) of forwarding.

Figure 145: M40e and M160 Router SFM Location

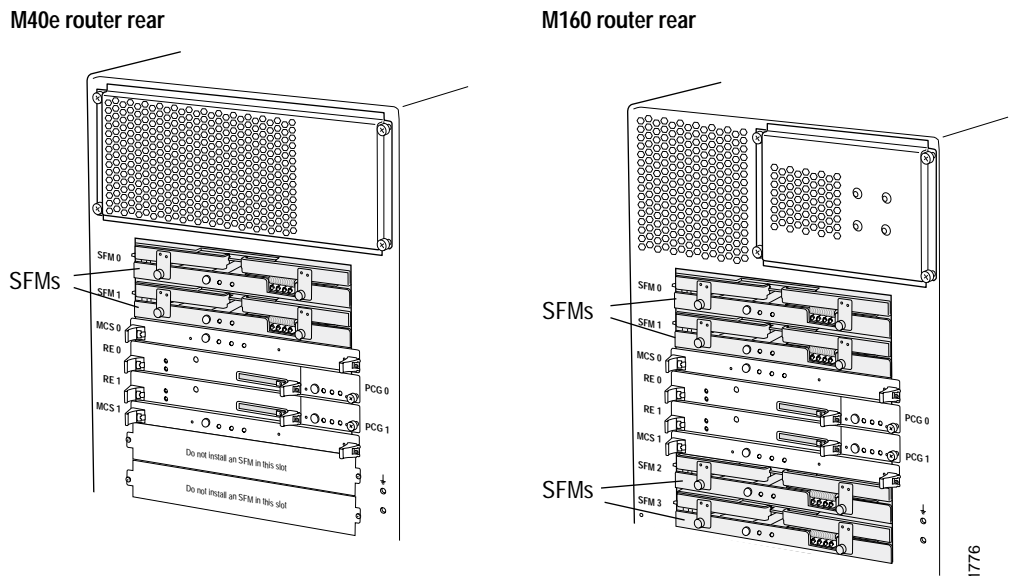

The SFMs are hot-removable and hot-insertable. Inserting or removing an SFM causes a brief interruption in forwarding performance (about 500 ms) as the Packet Forwarding Engine reconfigures the distribution of packets across the remaining SFMs.

Monitoring the SFM Status

To monitor the SFM status, follow these steps:

- Steps To Take**
1. Display the SFM Summary Status on page 349
 2. Display the SFM LED Status at the Command Line on page 351
 3. Check the SFM LED Status on the Faceplate on page 351
 4. Display the SFM Environmental Status on page 351

Step 1: Display the SFM Summary Status

Action To display the SFM summary status, use the following JUNOS software command-line interface (CLI) command:

```
user@host> show chassis sfm
```

Sample Output

```
user@host> show chassis sfm
Temp CPU Utilization (%) Memory Utilization (%)
Slot State (C) Total Interrupt DRAM (MB) Heap Buffer
0 Online 41 2 0 64 16 46
1 Offline --- Hard FPC error ---
2 Online 43 2 0 64 16 46
3 Online 44 2 0 128 7 46
```

What it Means The command output displays the SFM slot number: 0, 1, 2, or 3. The output also displays the operating status of each SFM as Online, Offline, or Empty.

In the sample output, the root cause of the SFM1 failure may be an FPC problem.

The command output displays the temperature of air passing by the SFM, in degrees Centigrade. It displays the SFM CPU usage, including the total percentage used by the SFM processor and the percentage used for interrupts.

The command output also displays the percentage of memory usage, including the total DRAM available to the SFM processor, in megabytes (MB), and the percentage of heap space (dynamic memory) being used by the SFM processor. Heap utilization greater than 80 percent can indicate a software problem (memory leak). The output shows the percentage of buffer space being used by the SFM processor for buffering internal messages.

Alternative Action If the SFM summary command output indicates that there is a problem, you can display more detailed SFM status information with the following CLI command:

```
user@host> show chassis sfm detail
```

The command output displays the following information:

Sample Output user@host> **show chassis sfm detail**

```
SFM status:
Slot 0 information:
  State           Online
  SPP Temperature 36 degrees C / 96 degrees F
  SPR Temperature 45 degrees C / 113 degrees F
  Total CPU DRAM  64 Mbytes
  Total SRAM      4 Mbytes
  Internet Processor I Version 1, Foundry IBM, Part number 3
  Start time:     2001-12-03 05:08:45 PST
  Uptime:         6 hours, 41 minutes, 17 seconds
Slot 1 information:
  [...Output truncated...]
Slot 2 information:
  [...Output truncated...]
Slot 3 information:
  [...Output truncated...]

Packet scheduling mode: Disabled
```

What It Means In addition to the command output displayed for the show chassis sfm command, the show chassis sfm detail command displays the temperature of air passing by the Switch Plane Processor (SPP) card and the Switch Plane Router (SPR) card (the two SFM serial components) in degrees Centigrade. The command output displays the total CPU DRAM and SRAM being used by the SFM processor. It also displays the time when the SFM became active and how long the SFM has been up and running. A small uptime means that the SFM came online a short time ago and could indicate a possible SFM error condition.

Alternative Action To display the status of a particular SFM, use the following CLI command:

```
user@host> show chassis sfm sfm-slot
```

Alternative Action To display detailed status information about a particular SFM, use the following CLI command:

```
user@host> show chassis sfm detail sfm-slot
```

Step 2: Display the SFM LED Status at the Command Line

Action To display the SFM LED status, use the following CLI command:

```
user@host> show chassis craft-interface
```

Sample Output

```
user@host> show chassis craft-interface
[...Output truncated...]
SFM LEDs:
SFM 0 1 2 3
-----
Amber . . * .
Green * * . *
Blue * * . *
```

What it Means The command output is for an M160 router. The SFMs in slots 0 and 1 are online and are functioning normally. The status colors represent the possible SFM operating states: Amber (Fail), Green (OK), and Blue (Master). The (*) indicates the current operating state. There are no SFMs in slots 2 and 3.

Step 3: Check the SFM LED Status on the Faceplate

Action To check the SFM LED status, remove the component cover and look on the SFM faceplate at the back of the M40e and M160 routers (see Figure 144 on page 348). Table 85 describes the SFM LED states.

Table 85: SFM LEDs

Color	Label	State	Description
Green	OK	On steadily	SFM is functioning normally.
		Blinking	SFM is starting up.
Amber	FAIL	On steadily	SFM has failed.

Step 4: Display the SFM Environmental Status

Action To display the SFM environmental information, use the following CLI command:

```
user@host> show chassis environment
```

Sample Output

```
user@host> show chassis environment
Class Item      Status  Measurement
Power PEM 0     OK
    PEM 1     OK
Temp
[...Output truncated...]
    SPP 0     OK    37 degrees C / 98 degrees F
    SPR 0     OK    46 degrees C / 114 degrees F
    SPP 1     OK    38 degrees C / 100 degrees F
    SPR 1     OK    48 degrees C / 118 degrees F
    SPP 2     OK    39 degrees C / 102 degrees F
    SPR 2     OK    54 degrees C / 129 degrees F
    SFM 3     Offline
[...Output truncated...]
```

What it Means The command output displays the status and temperature for the SFM and its two serialized components: the SPP card and the SPR card.

Alternative Action If there is a problem with the SFM status, you can display more detailed environmental information with the following CLI command:

```
user@host> show chassis environment sfm
```

```
user@host> show chassis environment sfm
SFM 0 status:
State                Online
SPP temperature      36 degrees C / 96 degrees F
SPR temperature      45 degrees C / 113 degrees F
SPP Power:
1.5 V                1501 mV
2.5 V                2485 mV
3.3 V                3291 mV
5.0 V                5020 mV
5.0 V bias           4974 mV
SPR Power:
1.5 V                1501 mV
2.5 V                2492 mV
3.3 V                3301 mV
5.0 V                5028 mV
5.0 V bias           4986 mV
8.0 V bias           8305 mV
CMB Revision         12
SFM 1 status:
[...Output truncated...]
SFM 2 status:
[...Output truncated...]
SFM 3 status:
State                Offline
- Hard FPC error
[...Output truncated...]
```

The command output displays the SFM slot, status, and temperature of the air flowing past the SPP card and the SPR card. It also displays information about the SFM power supplies. The chassis management bus (CMB) slave revision level is also displayed.

You can display the environmental status of a particular SFM with the following CLI command:

```
user@host> show chassis environment sfm sfm-lot
```

Displaying SFM Alarms

- Steps To Take** To display SFM alarms and error messages, follow these steps:
1. Display Current SFM Alarms on page 353
 2. Display SFM Error Messages in the System Log File on page 353
 3. Display SFM Error Messages in the Chassis Daemon Log File on page 354

Step 1: Display Current SFM Alarms

Action To display the current SFM alarms, use the following CLI command:

```
user@host> show chassis alarms
```

Sample Output

```
user@host> show chassis alarms
4 alarms currently active
Alarm time      Class  Description
2002-05-14 09:23:58 PDT Major SFM Failure
2002-05-14 09:23:55 PDT Major SFM Failure
2002-05-14 09:23:53 PDT Major SFM Failure
2002-05-14 09:20:51 PDT Major No SFM Online, the box is not forwarding
```

What it Means The command output displays the alarm date, time, severity level, and description.

Step 2: Display SFM Error Messages in the System Log File

Action To display the SFM error messages in the system log file, use the following CLI command:

```
user@host> show log messages
```

Sample Output

```
user@host> show log messages
Jun 11 20:31:11 hissy-re0 craftd[556]: Major alarm set, No SFM Online, the box is not forwarding
Jun 11 20:31:11 hissy-re0 alarmd[555]: Alarm set: SFM color=RED, class=CHASSIS, reason=No SFM Online,
the box is not forwarding
```

What it Means The messages system log file records the time the failure or event occurred, the severity level, a code, and a message description. You can also use the `show log messages | match sfm` command to see error messages that are generated when an SFM fails or is offline. Use this information to diagnose a power supply problem and to let the Juniper Networks Technical Assistance Center (JTAC) know what error messages were generated and the router events that occurred before and after the problem. For more information about system log messages, see the *JUNOS System Log Messages Reference*.

Step 3: Display SFM Error Messages in the Chassis Daemon Log File

The chassis daemon (`chassisd`) log file keeps track of the state of each chassis component.

Action To display the SFM error messages logged in the chassis daemon, use the following CLI command:

```
user@host> show log chassisd
```

Sample Output

```
user@host> show log chassisd
Jun 11 20:50:16 mcs_intr_handler fpm_mcsfd 10
Jun 11 20:50:16 mcs_intr mcs_ints_pending 0x7cbf20 button_status 0x0
Jun 11 20:50:16 bp_handle_button_intr button_status 0x0
Jun 11 20:50:16 mcs_intr_handler fpm_mcsfd 10
Jun 11 20:50:16 mcs_intr mcs_ints_pending 0x7cbf20 button_status 0x8
Jun 11 20:50:16 bp_handle_button_intr button_status 0x8
Jun 11 20:50:16 mcs_intr_handler fpm_mcsfd 10
Jun 11 20:50:16 mcs_intr mcs_ints_pending 0x7cbf20 button_status 0x8
Jun 11 20:50:16 bp_handle_button_intr button_status 0x8
Jun 11 20:50:16 received second FPM key press, clearing timer!
Jun 11 20:50:18 bp_button_timer: taking sfm 1 offline
Jun 11 20:50:18 take_sfm_offline - slot 1 reason 7
Jun 11 20:50:18 cleaning up sfm 1 connection
Jun 11 20:50:18 CMB cmd to SPP 1 [0xe9], Blue LED Off [0x16]
Jun 11 20:50:18 SPP 1 - Blue LED Off
Jun 11 20:50:18 send: fpc 0, sfm 1 offline
Jun 11 20:50:18 send: fpc 1, sfm 1 offline
Jun 11 20:50:18 send: fpc 2, sfm 1 offline
Jun 11 20:50:18 send: fpc 6, sfm 1 offline
Jun 11 20:50:18 send: fpc 7, sfm 1 offline
Jun 11 20:50:18 fpc 2, sfm 1 offline ack
Jun 11 20:50:18 fpc 2, sfm 1 offline ack, online 0xc7 online-acks 0x4
Jun 11 20:50:18 fpc 1, sfm 1 offline ack
Jun 11 20:50:18 fpc 1, sfm 1 offline ack, online 0xc7 online-acks 0x6
Jun 11 20:50:18 fpc 0, sfm 1 offline ack
Jun 11 20:50:18 fpc 0, sfm 1 offline ack, online 0xc7 online-acks 0x7
Jun 11 20:50:18 fpc 7, sfm 1 offline ack
Jun 11 20:50:18 fpc 7, sfm 1 offline ack, online 0xc7 online-acks 0x87
Jun 11 20:50:18 fpc 6, sfm 1 offline ack
Jun 11 20:50:18 fpc 6, sfm 1 offline ack, online 0xc7 online-acks 0xc7
Jun 11 20:50:18 sfm_offline_now plane 1 conn 0x8152638
Jun 11 20:50:18 CMB cmd to SPP 1 [0xe9], Assert PLL Bypass [0x13]
Jun 11 20:50:18 CMB cmd to SPP 1 [0xe9], Assert Board Reset [0x2e]
Jun 11 20:50:18 CMB cmd to SPP 1 [0xe9], Assert ASIC Reset [0x28]
Jun 11 20:50:18 CMB cmd to SPP 1 [0xe9], Disable Power [0x10]
Jun 11 20:50:18 SPP 1 - Disable Power [addr 0x9 cmd 0x10]
Jun 11 20:50:18 CMB readback SPP 1 [0xe9, 0xf2] -> 0x26
Jun 11 20:50:18 power disable verified, SPP 1
Jun 11 20:50:18 CMB cmd to SPP 1 [0xe9], Blue LED Off [0x16]
Jun 11 20:50:18 SPP 1 - Blue LED Off
Jun 11 20:50:18 CMB cmd to SPP 1 [0xe9], Green LED Off [0x1a]
Jun 11 20:50:18 SPP 1 - Green LED Off
Jun 11 20:50:18 check_sfm_online_alarm: present 0xf waiting 0x0 online 0xd
Jun 11 20:50:18 send_pfe_status(): sfm 0, sfm_online_mask 0xd fpc_online_mask 0xc7
Jun 11 20:50:18 send_pfe_status(): sfm 2, sfm_online_mask 0xd fpc_online_mask 0xc7
[...Output truncated...]
```

What It Means

The chassisd database provides the date, time, and a component status message. The chassisd database is dynamic. It is initialized at router startup and is updated when components are added or removed. You can search for multiple items in the chassisd log file by using the | match "item |item |item" command. For example, | match "sfm|kernel|tnp" is a search for error messages for the SFM, kernel, and Trivial Networking Protocol (TNP), and indicates communication issues between the Routing Engine and the Packet Forwarding Engine components.

Verifying SFM Failure

Steps To Take To verify SFM failure, follow these steps:

1. Check the SFM Connection on page 355
2. Check the SFM Fuses on page 355
3. Perform an SFM Swap Test on page 356

Step 1: Check the SFM Connection

Action To check the SFM connection, make sure that it is properly seated in the midplane. Check the thumbscrews on the ejector locking tabs.

Step 2: Check the SFM Fuses

Action Check for blown SFM fuses.

The M40e and M160 router fuses are located in a fuse box at the rear of the midplane, behind the lower rear impeller assembly. You must remove the lower impeller assembly to access the fuses, as described in the *M40e Router Hardware Guide*.

When the fuse for an SFM blows, the SFM stops functioning even though it is installed correctly and the power supplies are providing power to the router.

For the M40e and M160 routers, when a fuse has blown but the power supplies are still delivering power to router, the amber LED adjacent to the fuse lights. See Figure 146.

Figure 146: M40e M160 Router Fuses

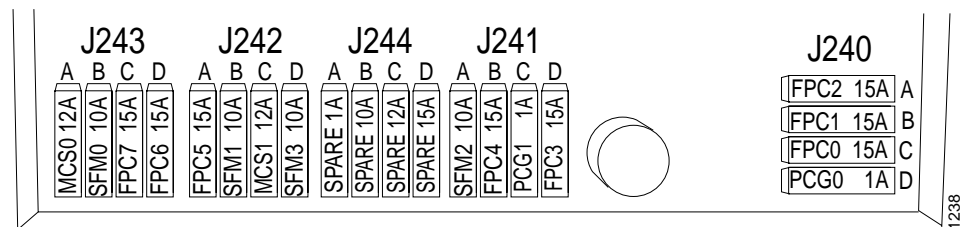

Another indication that a fuse has blown is that the colored indicator bulb inside it becomes visible through the clear cover on the fuse. For information about the indicator bulb color for each fuse type, see the appropriate router hardware guide.

A blown fuse can cause a component to fail even though it is correctly installed and the power supplies are functioning. Check for a blown fuse in the following circumstances:

The LED that indicates normal operation for the component fails to light.

The appropriate CLI show chassis environment command indicates that the component is installed but is not receiving power.

Step 3: Perform an SFM Swap Test



CAUTION: Before performing a swap test, always check for bent pins in the midplane and check the SFM for stuck pins in the connector. Pins stuck in the component connector can damage other good slots during a swap test.

Action To perform a swap test on an SFM, follow these steps:

1. Remove the chassis rear component cover by loosening the screws on the corners of the cover and pulling it straight out from the chassis.
2. Remove the SFM, as described in the M40e and M160 router hardware guides.
3. Take the SFM offline by doing one of the following:

Use the following CLI command:

```
user@host> request chassis sfm slot slot-number offline
```

Press and hold the offline button on the SFM faceplate at the rear of the router until the SFM OK LED turns off (about 5 seconds).

4. Replace the SFM with one that you know works.
5. Bring the SFM online by doing one of the following:

Use the following CLI command:

```
user@host> request chassis sfm slot slot-number online
```

Press and hold the offline button on the SFM faceplate until the green OK LED lights (about 5 seconds).

6. Reinstall the rear component cover and tighten the screws to secure it to the chassis.
7. Check the SFM status. See “Display the SFM Summary Status” on page 349.

Getting SFM Hardware Information

Steps To Take To get the hardware information you need to return a failed SFM, follow these steps:

1. Display SFM Hardware Information on page 357
2. Locate the SFM Serial Number ID Label on page 357

Step 1: Display SFM Hardware Information

Action To display the SFM hardware information, use the following CLI command:

```
user@host> show chassis hardware
```

Sample Output

```
user@host> show chassis hardware
Item      Version Part number Serial number Description
Chassis                20079      M160
[...Output truncated...]
SFM 0 SPP    REV 04  710-001228 AA2860
SFM 0 SPR    REV 01  710-001224 AB0139      Internet Processor I
SFM 1 SPP    REV 04  710-001228 AA2859
SFM 1 SPR    REV 02  710-001224 AA9861      Internet Processor I
SFM 2 SPP    REV 06  710-001228 AB3082
SFM 2 SPR
SFM 3 SPP    REV 04  710-001228 AA1998
SFM 3 SPR    REV 01  710-001224 AB0137      Internet Processor I
[...Output truncated...]
```

What it Means The command output displays the SFM slot number and SFM serial component (SPP and SPR) card names, SFM revision level, part number, serial number, and description.

Step 2: Locate the SFM Serial Number ID Label

Action To locate the SFM serial number ID label, look on the left side of the SFM top panel (see Figure 147).

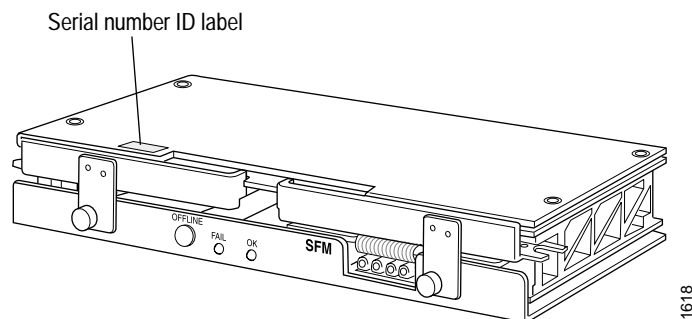
Figure 147: SFM Serial Number ID Label**Replacing the SFM**

The SFMs are hot-removable and hot-insertable. You can remove and replace SFMs without powering down the router or disrupting the routing functions. However, you must take an SFM offline before replacing it.

Inserting or removing an SFM causes a brief interruption in forwarding performance (about 500 ms) as the Packet Forwarding Engine reconfigures the distribution of packets across the remaining SFMs.

Action To replace an SFM, see “Return the Failed Component” on page 86, or the procedure to return a field-replaceable unit in the M40e or M160 router hardware guide.

