

Chapter 27

Monitoring the MCS

You monitor and maintain the Miscellaneous Control Subsystem (MCS) to provide control and monitoring functions for router components and to provide SONET/SDH clocking for the M40e and M160 routers. (See Table 86.)

Table 86: Checklist for Monitoring the MCS

Monitor MCS Tasks	Command or Action
Understanding the MCS on page 360	
Checking the MCS Status on page 362	
1. Check the MCS Environmental Status on page 362	show chassis environment mcs
2. Check the MCS Status from the Craft Interface on page 363	show chassis craft-interface
3. Check the MCS LEDs on page 364	Check the LEDs on the MCS faceplate.
Verifying MCS Failure on page 365	
1. Check the MCS Fuses on page 365	The M40e and M160 router fuses are located in a fuse box at the rear of the midplane, behind the lower rear impeller assembly.
2. Perform an MCS Swap Test on page 366	Remove the MCS and replace it with one that you know works.
Getting MCS Hardware Information on page 367	
1. Display the MCS Hardware Information on page 367	show chassis hardware
2. Locate the MCS Serial Number ID Label on page 368	Look at the bottom left of the MCS board.
Returning the MCS on page 368	See "Return the Failed Component" on page 86, or follow the procedure in the M40e or M160 router hardware guide.

Understanding the MCS

Purpose Inspect the MCS to ensure that control and monitoring functions for router components and SONET/SDH clocking for the router function normally.

What Is an MCS The MCS is a component of the host module on M40e and M160 routers (see Figure 148). The MCS works with the Routing Engine to provide control and monitoring functions for router components and to provide SONET/SDH clocking for the router.

Figure 148: MCS Component

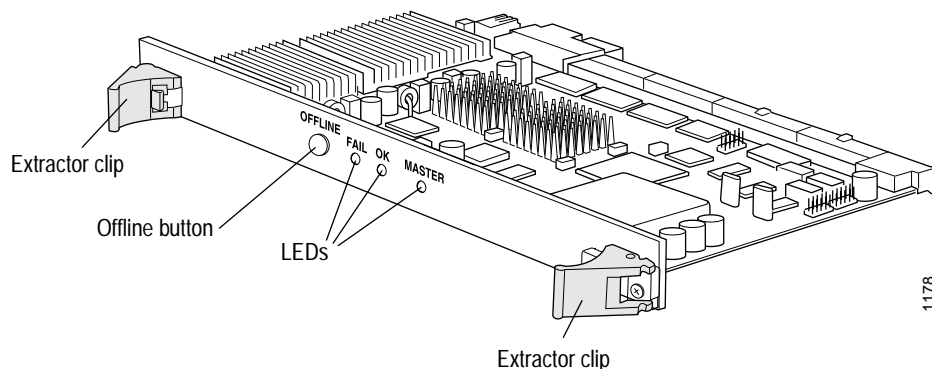

The router can be equipped with up to two MCSs for redundancy. If two MCSs are installed, one acts as the master MCS and the other acts as a backup. If the master MCS fails or is removed, the backup MCS restarts and becomes the master MCS.



NOTE: The host modules (RE0 working with MCS0 and RE1 working with MCS1) actually have the master and backup role.

Each MCS requires a Routing Engine to be installed in an adjacent slot. MCS0 installs above RE0, and MCS1 installs below RE1. Even if an MCS is physically installed in the chassis, it does not function if there is no Routing Engine present in the adjacent slot.

The MCS installs into the midplane from the back of the chassis (see Figure 149).

Figure 149: M40e and M160 Router MCS Location

M40e router rear

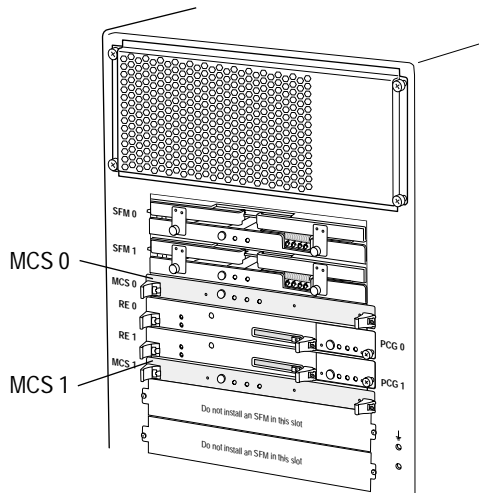

M160 router rear

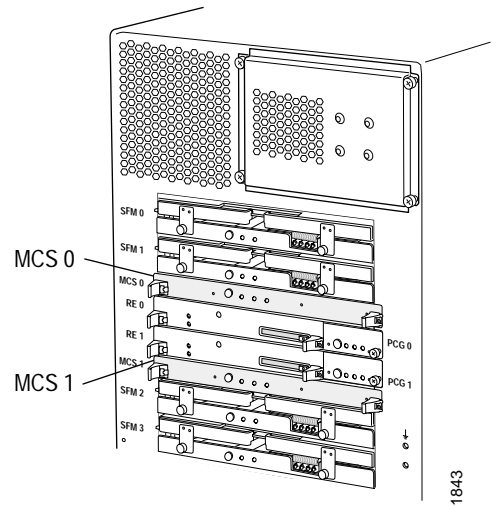

- See Also**
- Monitoring the Host Module on page 341
 - Monitoring the Routing Engine on page 125
 - Monitoring Redundant Routing Engines on page 491
 - Monitoring Redundant MCSs on page 567

Checking the MCS Status

Steps To Take To check the MCS status, follow these steps:

1. Check the MCS Environmental Status on page 362
2. Check the MCS Status from the Craft Interface on page 363
3. Check the MCS LEDs on page 364

Step 1: Check the MCS Environmental Status

Action To check the MCS environmental status, use the following JUNOS software command-line interface (CLI) command:

```
user@host> show chassis environment mcs
```

Sample Output

```
user@host> show chassis environment mcs
MCS 0 status:
  State           Online Master
  Temperature      43 degrees C / 109 degrees F
  Power:
  3.3 V           3318 mV
  5.0 V           4974 mV
  12.0 V on       12
  FPGA Revision   13
MCS 1 status:
  State           Online Standby
  Temperature      58 degrees C / 136 degrees F
  Power:
  3.3 V           3317 mV
  5.0 V           5006 mV
  12.0 V          11843 mV
  5.0 V bias      4998 mV
  8.0 V bias      8195 mV
  BUS Revision    12
  FPGA Revision   255
```

What It Means The `show chassis environment mcs` command is available on the M40e and M160 routers only. The command output displays environmental information about both MCSs installed in the router or about an individual MCS. The MCS status can be Present, Online, Offline, or Empty. The command also indicates that the MCS is the master MCS. The command output also displays the temperature of the air flowing past the MCS, information about MCS power supplies, field-programmable gate array (FPGA) revision information, and the revision level of the chassis management bus (CMB) slave.

Alternative Action To display the environmental status of a particular MCS, use the following JUNOS CLI operational mode command:

```
user@host> show chassis environment mcs slot
```

Step 2: Check the MCS Status from the Craft Interface

Action To display the MCS LED status from the craft interface, use the following JUNOS software operational mode CLI command:

```
user@host> show chassis craft-interface
```

Sample Output user@host> show chassis craft-interface
[...Output truncated...]

```
MCS and SFM LEDs:
MCS 0 1 SFM 0 1 2 3
-----
Amber . . .
Green . . .
Blue * * *
```

What It Means If the amber FAIL LED is on, check for current MCS alarms.

Alternative Action Look at the Host Module LEDs on the craft interface. The LEDs indicate the MCS status. (See Figure 150.)

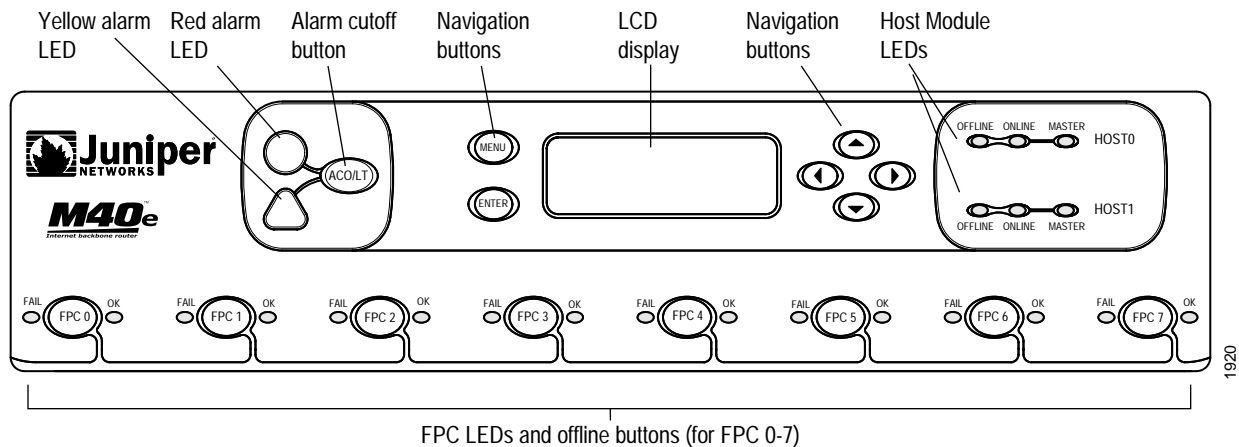

Figure 150: M40e and M160 Router Craft Interface Host Module LEDs



Three host module LEDs—one green MASTER, one green ONLINE, and one red OFFLINE—located on the upper right of the craft interface indicate the status of each host module. The LEDs marked HOST0 show the status of the Routing Engine in slot RE0 and the MCS in slot MCS0. The LEDs marked HOST1 show the status of the Routing Engine in slot RE1 and the MCS in slot MCS1.

Table 87 describes the functions of the host module LEDs.

Table 87: Host Module LEDs

Label	Shape	Color	State	Description
MASTER		Green	On steadily	Host module (Routing Engine and MCS) is functioning as master.
ONLINE		Green	On steadily	Host module is present and operational.
			Blinking	Host module is starting up.
OFFLINE		Red	On steadily	Host module is not present, or is present but not operational.

Step 3: Check the MCS LEDs

Action To check the MCS status, look at the LEDs on the MCS faceplate.

Table 88 describes the functions of these LEDs.

Table 88: MCS LEDs

Color	Label	State	Description
Blue	MASTER	On steadily	MCS is master.
Green	OK	On steadily	MCS is operating normally.
		Blinking	MCS is starting up.
Amber	FAIL	On steadily	MCS has failed.

When the MCS is functioning normally, the green OK LED remains on steadily. If the amber FAIL LED is on, check for MCS alarms.

Verifying MCS Failure

Steps To Take To verify MCS operation failure, follow these steps:

1. Check the MCS Fuses on page 365
2. Perform an MCS Swap Test on page 366

Step 1: Check the MCS Fuses

Action Check the MCS fuses to check for failure.

The M40e and M160 router fuses are located in a fuse box at the rear of the midplane, behind the lower rear impeller assembly. You must remove the lower impeller assembly to access the fuses, as described in the appropriate router hardware guide.

When the fuse for an MCS blows, the MCS stops functioning even though it is installed correctly and the power supplies are providing power to the router.

For the M40e and M160 routers, when a fuse has blown but the power supplies are still delivering power to router, the amber LED adjacent to the fuse lights. See Figure 151.

Figure 151: M40e M160 Router Fuses

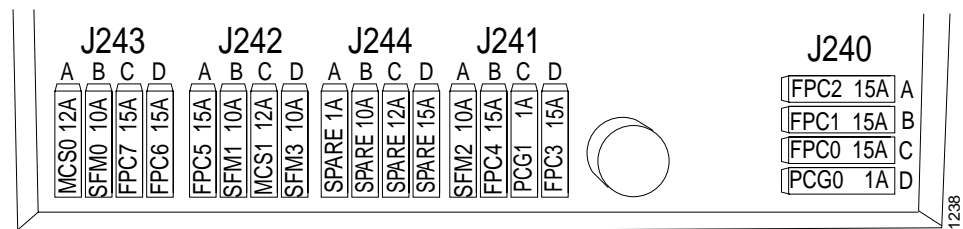

Another indication that a fuse has blown is that the colored indicator bulb inside it becomes visible through the clear cover on the fuse. For information about the indicator bulb color for each fuse type, see the appropriate router hardware guide.

A blown fuse can cause a component to fail even though it is correctly installed and the power supplies are functioning. Check for a blown fuse in the following circumstances:

The LED that indicates normal operation for the component fails to light.

The appropriate CLI show chassis environment command indicates that the component is installed but is not receiving power.

Step 2: Perform an MCS Swap Test

The MCS can fail and not start, or it can cause a connectivity problem between the Routing Engine and the Packet Forwarding Engine components, such as the Flexible PIC Concentrator (FPC) and Switching and Forwarding Module (SFM). You can perform a swap test on the MCS to try to pinpoint the problem.



CAUTION: The MCS is hot-pluggable. Routing functions are interrupted until a replacement is installed. You should perform a swap test during a maintenance window.

Before performing a swap test, always check for bent pins in the midplane and check the MCS for stuck pins in the connector. Pins stuck in the component connector can damage other good slots during a swap test.

Action To perform a swap test on an MCS, remove it and replace it with one that you know works.

Normally, if two host modules are installed in the router, HOST0 functions as the master and HOST1 as the backup. You can remove the backup host module (or either of its components) without interrupting the functioning of the router. If you take the master host module offline, the router reboots and the backup host module becomes the master. If the router has only one host module, taking it offline causes the router to shut down.

The host module is taken offline and brought back online as a unit. Before you replace the Routing Engine or an MCS, you must take the host module offline; the host module is hot-pluggable.

To remove an MCS, follow these steps:

1. Place an electrostatic bag or antistatic mat on a flat, stable surface to receive the Routing Engine.
2. Attach an electrostatic discharge (ESD) strap to your bare wrist and connect the strap to one of the ESD points on the chassis.
3. Remove the rear component cover by loosening the screws at the corners of the cover and pulling it straight off of the chassis.
4. If two host modules are installed, check whether the MCS you are removing belongs to the master host module. Use the `show chassis environment mcs` CLI command or check the MCS LEDs. If it does, switch mastership to the standby host module. You can change the default mastership by including the `routing-engine` statement at the `[edit chassis redundancy]` hierarchy level in the configuration, as described in the *JUNOS System Basics Configuration Guide*.

- On the console or other management device connected to the Routing Engine that is paired with the MCS you are removing, enter CLI operational mode and issue the following command. The command shuts down the Routing Engine cleanly, so its state information is preserved.

```
user@host> request system halt
```

Wait to continue until all software processes have shut down.

- Flip the ends of the extractor clips outward.
- Grasp the extractor clips and slide the unit about halfway out of the chassis.
- Place one hand under the MCS to support it, slide it completely out of the chassis, and place it on the antistatic mat or in the electrostatic bag.
- Align the rear of the MCS with the guides inside the chassis and slide it in completely.
- Press the extractor clips on the left and right sides of the MCS inward.
- Verify that the green LED labeled OK on the MCS faceplate is lit. Also check the host module LEDs on the craft interface to verify that the green LED labeled ONLINE is lit for the host module to which the MCS belongs.

You can also verify correct MCS functioning by using the show chassis environment mcs command.

- Reinstall the rear component cover and tighten the screws at the corners to secure it to the chassis.

Getting MCS Hardware Information

Steps To Take To get MCS hardware information, follow these steps:

- Display the MCS Hardware Information on page 367
- Locate the MCS Serial Number ID Label on page 368

Step 1: Display the MCS Hardware Information

Action To display the MCS hardware information, use the following CLI command:

```
user@host> show chassis hardware
```

Sample Output

```
user@host> show chassis hardware
Hardware inventory:
Item      Version Part number Serial number  Description
Chassis                               M40e
[...Output truncated...]
Routing Engine 0                      d8000007c8460a01 RE-2.0
MCS 0      REV 11 710-001226 AS4709
[...Output truncated...]
```

What It Means The command output displays the MCS slot number, revision level, part number, and serial number. Give this information to the Juniper Networks Technical Assistance Center (JTAC) if the MCS fails.

Step 2: Locate the MCS Serial Number ID Label

Action To locate the MCS serial number ID label, look on the bottom left side of the board, as shown in Figure 152.

Figure 152: MCS Serial Number ID Label

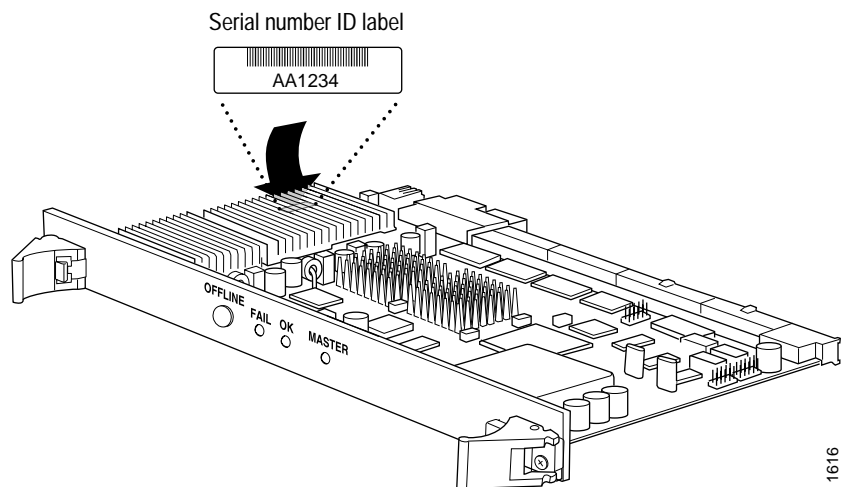

Returning the MCS

Action To return the MCS, see “Replacing a Failed Component” on page 122, or the procedure to return a field-replaceable unit in the M40e or M160 router hardware guide.