



**Security Threat Response Manager**

# **STRM Installation Guide**

***Release 2009.1***

**Juniper Networks, Inc.**

1194 North Mathilda Avenue

Sunnyvale, CA 94089

USA

408-745-2000

**[www.juniper.net](http://www.juniper.net)**

Published: 2010-02-15

## Copyright Notice

Copyright © 2008 Juniper Networks, Inc. All rights reserved. Juniper Networks and the Juniper Networks logo are registered trademarks of Juniper Networks Inc. in the United States and other countries. All other trademarks, service marks, registered trademarks, or registered service marks in this document are the property of Juniper Networks or their respective owners. All specifications are subject to change without notice. Juniper Networks assumes no responsibility for any inaccuracies in this document or for any obligation to update information in this document. Juniper Networks reserves the right to change, modify, transfer, or otherwise revise this publication without notice.

## FCC Statement

The following information is for FCC compliance of Class A devices: This equipment has been tested and found to comply with the limits for a Class A digital device, pursuant to part 15 of the FCC rules. These limits are designed to provide reasonable protection against harmful interference when the equipment is operated in a commercial environment. The equipment generates, uses, and can radiate radio-frequency energy and, if not installed and used in accordance with the instruction manual, may cause harmful interference to radio communications. Operation of this equipment in a residential area is likely to cause harmful interference, in which case users will be required to correct the interference at their own expense. The following information is for FCC compliance of Class B devices: The equipment described in this manual generates and may radiate radio-frequency energy. If it is not installed in accordance with NetScreen's installation instructions, it may cause interference with radio and television reception. This equipment has been tested and found to comply with the limits for a Class B digital device in accordance with the specifications in part 15 of the FCC rules. These specifications are designed to provide reasonable protection against such interference in a residential installation. However, there is no guarantee that interference will not occur in a particular installation. If this equipment does cause harmful interference to radio or television reception, which can be determined by turning the equipment off and on, the user is encouraged to try to correct the interference by one or more of the following measures: Reorient or relocate the receiving antenna. Increase the separation between the equipment and receiver. Consult the dealer or an experienced radio/TV technician for help. Connect the equipment to an outlet on a circuit different from that to which the receiver is connected.

Caution: Changes or modifications to this product could void the user's warranty and authority to operate this device.

## Disclaimer

THE SOFTWARE LICENSE AND LIMITED WARRANTY FOR THE ACCOMPANYING PRODUCT ARE SET FORTH IN THE INFORMATION PACKET THAT SHIPPED WITH THE PRODUCT AND ARE INCORPORATED HEREIN BY THIS REFERENCE. IF YOU ARE UNABLE TO LOCATE THE SOFTWARE LICENSE OR LIMITED WARRANTY, CONTACT YOUR JUNIPER NETWORKS REPRESENTATIVE FOR A COPY.

*Configuring DSMs*  
Release 2009.1

Copyright © 2008, Juniper Networks, Inc.

All rights reserved. Printed in USA.

Revision History

October 2009—Revision 1

The information in this document is current as of the date listed in the revision history.

# CONTENTS

---

## ABOUT THIS GUIDE

- Conventions 1
- Technical Documentation 1
- Contacting Customer Support 2

---

## 1 PREPARING FOR YOUR INSTALLATION

- Deploying STRM 3
- Additional Hardware Requirements 5
- Additional Software Requirements 5
- Browser Support 6
- Preparing Your Network Hierarchy 6
- Identifying Network Settings 7
- Identifying Security Monitoring Log Sources 7

---

## 2 INSTALLING STRM

- Setting Up Appliances 9
- Accessing STRM 19

---

## A CHANGING NETWORK SETTINGS

- Changing Network Settings in an All-in-One Console 21
- Changing the Network Settings of a Console in a Multi-System Deployment 24
- Changing the Network Settings of a Non-Console in a Multi-System Deployment 29

---

## C REINSTALLING STRM

- About the Recovery Partition 35
- Reinstalling STRM 36

---

## INDEX



# ABOUT THIS GUIDE



The *STRM Installation Guide* provides you with information on setting up STRM. STRM appliances are pre-installed with software and CentOS 5.3; however, you can install STRM software on your own appliances using Red Hat Enterprise Linux 5.3. This guide assumes a working knowledge of networking and Linux systems

---

## Conventions

The following table lists conventions that are used throughout this guide.

**Table 1** Icons

Icon	Type	Description
	Information note	Information that describes important features or instructions.
	Caution	Information that alerts you to potential loss of data or potential damage to an application, system, device, or network.
	Warning	Information that alerts you to potential personal injury.

---

## Technical Documentation

You can access technical documentation, technical notes, and release notes directly from the Juniper Customer Support web site at <https://www.juniper.net/support/>. Once you access the Juniper Customer Support web site, locate the product and software release for which you require documentation. Your comments are important to us. Please send your e-mail comments about this guide or any of the Juniper Networks documentation to:

[techpubs-comments@juniper.net](mailto:techpubs-comments@juniper.net).

Include the following information with your comments:

- Document title
- Page number

---

**Contacting  
Customer Support**

To help you resolve any issues that you may encounter when installing or maintaining STRM, you can contact Customer Support as follows:

- Open a support case using the Case Management link at <http://www.juniper.net/support>.
- Call 1-888-314-JTAC (from the United States, Canada, or Mexico) or 1-408-745-9500 (from elsewhere).

# 1

## PREPARING FOR YOUR INSTALLATION

Your STRM deployment will consist of STRM installed on one or multiple systems. You can use the STRM three-tier architecture to install components on a single server for small enterprises or distributed across multiple servers for maximum performance and scalability in large enterprise environments:

To ensure a successful STRM deployment, adhere to the recommendations in this document.

This chapter provides information about planning your STRM deployment including:

- [Deploying STRM](#)
- [Additional Hardware Requirements](#)
- [Additional Software Requirements](#)
- [Browser Support](#)
- [Preparing Your Network Hierarchy](#)
- [Identifying Network Settings](#)
- [Identifying Security Monitoring Log Sources](#)

---

### Deploying STRM

You can deploy STRM using STRM appliances or STRM software installed on your own hardware. This section provides information about deploying STRM including:

- [STRM Components](#)
- [Examples of STRM Deployments](#)

A STRM appliance includes STRM software and a CentOS-5.3 operating system. For further information about STRM appliances, see the *Hardware Installation Guide*.

**STRM Components** STRM components that can exist in your deployment include:



**Note:** For more information on each STRM component, see the *STRM Administration Guide*.

- **Flow Collector** - Passively collects traffic flows from your network through span ports or network taps. The Flow Collector also supports the collection of external flow-based data sources, such as NetFlow. You can install a Flow Collector on your own hardware or use one of the Flow Collector appliances.
- **Flow Processor** - Normalizes flows sent from one or more Flow Collector by consolidating, aggregating, and removing duplicate flows. The Flow Collector can also create *superflows* (grouped flows) before the flows reach the Classification Engine.
- **Classification Engine** - Analyzes flows to classify and identify all traffic in the enterprise network into multiple objects.
- **Console** - Provides the user interface for STRM. The Console provides real time views, reports, alerts, and in-depth flow views of network traffic and security threats. Using the Console, you can also manage distributed STRM deployments.

You access the Console from a standard web browser. When you access the system, a prompt appears for a user name and password, which you configure during the installation process. You must also have Java installed on your desktop system. For information about software requirements, see [Additional Software Requirements](#).

- **Update Daemon** - Writes to the database and TopN data. Typically, the Update Daemon is installed on the Console.
- **Flow Writer** - Writes the flow and asset profile data.
- **Event Collector** - The Event Collector gathers events from local and remote device sources. The Event Collector normalizes events, and then sends the information to the Event Processor. Before sending information to the Event Processor, the Event Collector bundles identical events to conserve system usage. During this process, Magistrate risk factors map the events to the STRM Identification System, and then creates the bundles.
- **Event Processor** - Processes events collected from one or more Event Collector. Once received, the Event Processor correlates the information from STRM and distributes the information to the appropriate area, depending on the type of event. The Event Processor also includes information gathered by STRM to indicate behavioral changes or policy violations for the event. Rules are applied to the events that allow the Event Processor to process events according to the configured rules. Once complete, the Event Processor sends the events to the Magistrate.
- **Magistrate** - Provides the core processing components. You can add one Magistrate component for each deployment. The Magistrate provides views, reports, alerts, and analysis of network traffic and security events. The Magistrate processes the event against the defined custom rules to create an offense. If there is no match to a custom rule, the Magistrate uses default rules

to process the event. An offense is an event that has been processed through STRM using multiple inputs, individual events, and events combined with analyzed behavior and vulnerabilities. Magistrate prioritizes the offenses and assigns a magnitude value based on several factors, including number of events, severity, relevance, and credibility.

**Examples of STRM Deployments**

The following figure shows an example of a small deployment using STRM and Flow Collector appliances.

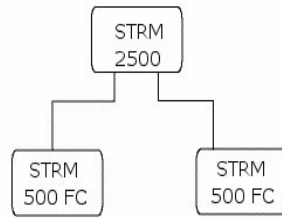

The following figure shows an example of a multisystem deployment using a mixture of Flow Collector and STRM appliances.

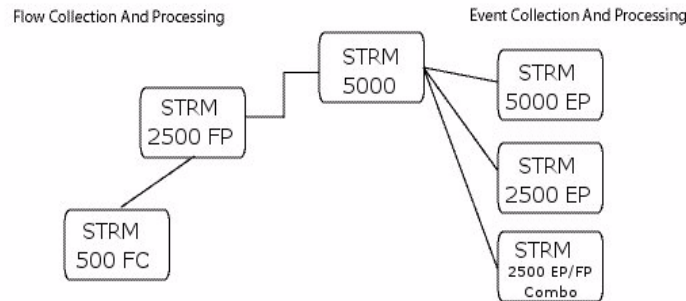

**Additional Hardware Requirements**

Before installing your STRM systems, make sure you have access to the additional hardware components:

- Uninterrupted Power Supply (UPS)



**Note:** To make sure that your STRM data is preserved during a power failure, we highly recommend that all STRM appliances or systems running STRM software that store data, such as, Consoles Event Processors, or Flow Processors be equipped with a Uninterrupted Power Supply (UPS).

**Additional Software Requirements**

Before installing STRM, make sure you have Java Runtime Environment installed on your system. You can download Java version 1.6.0\_13 X86 at the following web site: <http://java.com/>.



**Note:** Make sure that you install Java Runtime Environment on your desktop system, not the STRM appliance.

**Browser Support**

You must have a browser installed on your client system to access the STRM interface. STRM supports the following web browsers:

- Microsoft Internet Explorer 7.0
- Firefox 3.0

**Preparing Your Network Hierarchy**

STRM uses the network hierarchy to understand your network traffic and provide you with the ability to view network activity for your entire deployment. STRM supports any network hierarchy that can be defined by a range of IP addresses. You can create your network based on many different variables, including geographical or business units. For example, your network hierarchy may include corporate IP address ranges (internal or external), physical departments or areas, mails servers, and web servers.

After you define the STRM components you want to add to your network hierarchy and install STRM, you can then configure the network hierarchy using the STRM Console. For each STRM component you want to add to your network hierarchy, use the following table as a job aid to indicate each network component (object) in your network map.

**Table 1-1** Network Hierarchy

Description	Name	IP/CIDR Value	Weight

At a minimum, we recommend that you define objects in the network hierarchy for:

- Internal/external Demilitarized zone (DMZ)
- Virtual Private Network (VPN)
- All internal IP address space (for example, 0.0.0.0/8)
- Proxy servers
- Network Address Translation (NAT) IP address range
- Server Network subnets
- Voice over IP (VoIP) subnets

For more information, see the *STRM Administration Guide - Setting Up STRM, Creating Your Network Hierarchy*.

**Identifying Network Settings**

Before you install STRM, you must have the following information for each system you want to install:

- Hostname
- IP address
- Network mask address
- Subnet mask
- Default gateway address
- Primary Domain Name System (DNS) server address
- Secondary DNS server (optional) address
- Public IP address for networks using NAT
- E-mail server name
- Network Time Protocol (NTP) server (Console only) or time server name

**Identifying Security Monitoring Log Sources**

STRM collects and correlates events received from external sources including:

- Security equipment, such as firewalls, VPNs, and Intrusion Detection Systems (IDSs)
- Host or application security logs such as window logs

Device Support Modules (DSMs) and Flow Collectors allow you to integrate STRM with this external data.

STRM automatically discovers log sources that send syslog messages to an Event Collector. Automatically discovered log sources appear in the Log Sources window within the STRM Admin interface. For more information, see the *STRM Administration Guide*.

You must add non-syslog based information sources to your deployment manually. For more information, see the *Managing Log Sources Guide*. For each log source you want to add to your deployment, record log source information in the following table.

**Table 1-2** Log Sources

Log Source Type	QTY	Product Name/Version	Link Speed & Type	Msg Level	Avg Log Rate (Event/Sec)	No. of Users	Network Location	Geographic Location	Credibility (0 to 10)

Table 1-2 Log Sources (continued)

Log Source Type	QTY	Product Name/Version	Link Speed & Type	Msg Level	Avg Log Rate (Event/Sec)	No. of Users	Network Location	Geographic Location	Credibility (0 to 10)
-----------------	-----	----------------------	-------------------	-----------	--------------------------	--------------	------------------	---------------------	-----------------------

Where:

- **Log Source Type** - Specifies the type of log source, such as firewall, router, or VPN log sources.
- **QTY** - Specifies how many log sources you have of each log source type.
- **Product Name/Version** - Specifies the log source product name and version number.
- **Link Speed & Type** - Specifies the maximum network link speed (in Kbps) for firewall, router, and VPN log sources. For the type, record the primary application of the host system, for example, e-mail, anti-virus, domain controller, or a workstation.
- **Msg Level** - Specifies the message level you want to log. For example, critical, informational, or debug.
- **Avg Log Rate (Event/Sec)** - Specifies the average event rate per second.
- **No. of Users** - Specifies the maximum number of hosts/users using or being served by this log source.
- **Network Location** - Specifies whether this log source is located on the Internet DMZ, Intranet, or Extranet DMZ.
- **Geographic Location** - Specifies if the log sources are located on the same LAN as STRM or if they are sending logs over the WAN identified in the Link Speed & Type column.
- **Credibility** - Specifies the integrity of an event or offense as determined by the credibility rating from log sources. Credibility increases as multiple sources report the same event.

# 2

## INSTALLING STRM

This chapter provides information on installing your STRM system including:

- [Setting Up Appliances](#)
- [Accessing STRM](#)

---

### Setting Up Appliances

A STRM appliance includes STRM software and a CentOS-5.3 operating system. This section provides information for how to set up your appliance. For more information about appliances, see the *Hardware Installation Guide*.

This section includes:

- [Preparing Your Appliance](#)
- [Setting Up Your STRM Appliance](#)
- [Setting up Your Flow Appliance](#)

### Preparing Your Appliance

To set up your appliance:

**Step 1** Install all necessary hardware.

For information on rack mounting your STRM appliance, see the *Hardware Installation Guide*.

**Step 2** Connect a laptop to the console port on the front of the appliance.



**Note:** If you use a laptop to connect to the system, you must use a terminal program, such as *HyperTerminal*, to connect to the system. Make sure you set **Connect Using** to the appropriate COM port of the serial connector and **Bits per second** to 9600. You must also set **Stop Bits** (1), **Data bits** (8), and **Parity** (None).

**Step 3** Using the keyboard with monitor or laptop, log in using the default username and password.



**Note:** The username are case sensitive.

Username: `root`  
Password: `password`

Press Enter.

The End User License Agreement (EULA) appears.

**Step 4** Read the information in the window. Press the Spacebar to advance each window until you have reached the end of the document. Type **yes** to accept the agreement, and then press Enter.

**Step 5** Enter your activation key and press Enter.



**Note:** The letter *I* and the number 1 (one) are treated the same, as are the letter *O* and the number 0 (zero).

**Setting Up Your STRM Appliance**

To set up your STRM appliance:

**Step 1** To select a tuning template:

- a Using the up/down arrow keys, select one of the following tuning templates:
  - **Enterprise** - Tunes properties for internal network activity.
  - **University** - Tunes properties for education-specific concerns.
- b Press Enter to select **Next**.

The Set Time and Date window appears.

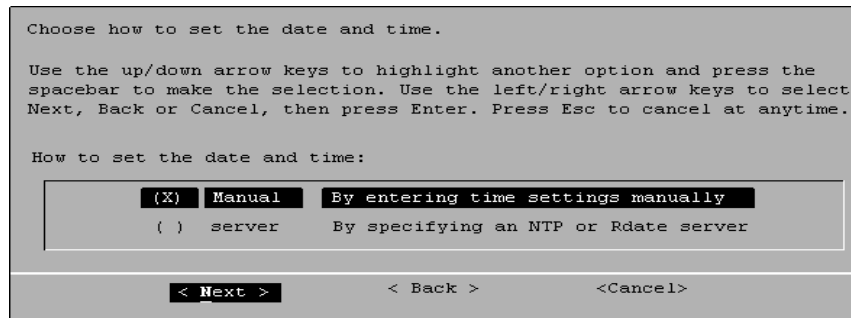

**Step 2** Using the up/down arrow keys, highlight the method you want to use to set the date and time, and then use the spacebar to select that option:

- **Manual** - Allows you to manually input the time and date. Use the Tab key to select the **Next** option. Press Enter. The Current Date and Time window appears. Go to [Step 3](#).
- **Server** - Allows you to specify your time server. Use the Tab key to select the **Next** option. Press Enter. The Enter Time Server window appears. Go to [Step 4](#).

**Step 3** To manually enter the time and date:

- a Enter the current date and time.
- b Using the Tab key, select **Next**. Press Enter.
- c Go to [Step 5](#).

**Step 4** To specify a time server:

- a In the text field, enter the time server name or IP address.

- b Using the Tab key, select **Next**. Press Enter.

The Time Zone Continent window appears.

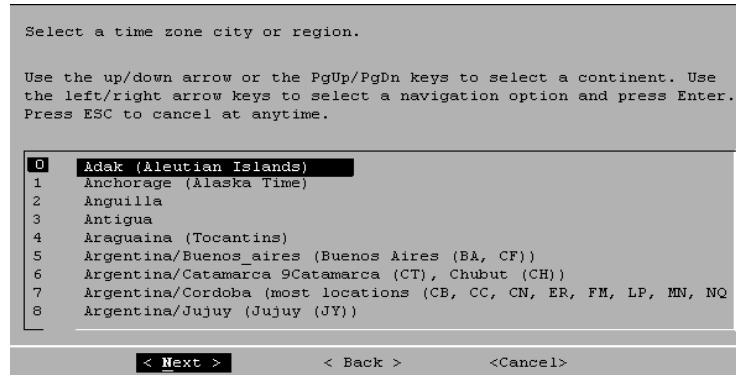

**Step 5** To select the time zone continent:

- a Using the up/down arrow keys, or the page up/page down keys, select your time zone continent or area.
- b Press Enter to select **Next**.

The Time Zone Region window appears.

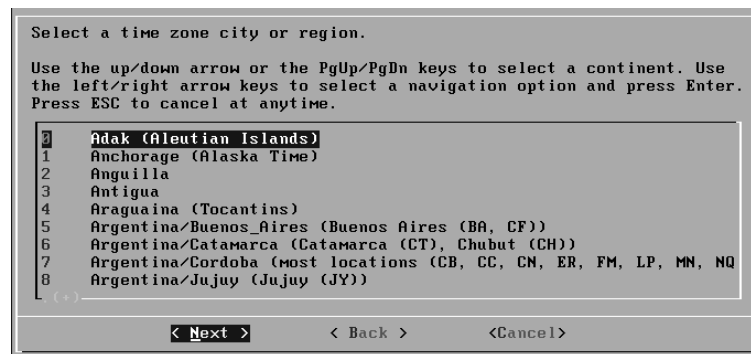

**Note:** The options that appear in this window are regions that are associated with the continent or area previously selected.

- c Using the up/down arrow keys, or the page up/page down keys, select your time zone region.
- d Press Enter to select **Next**.

The Choose which Internet protocol to use window appears.

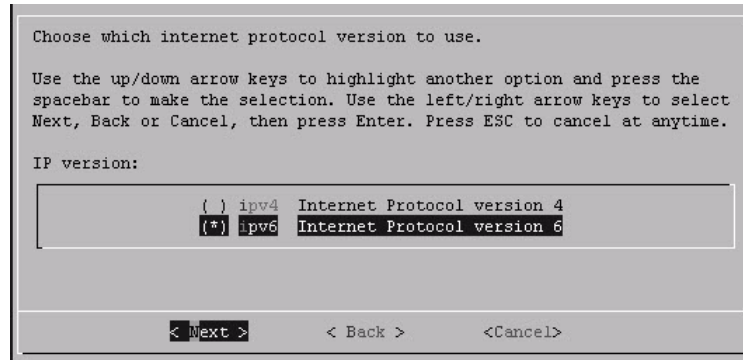

**Step 6** To select the Internet protocol:

- a Using the up/down arrow keys, and then the spacebar, select one of the following options:

- **IPv4**
- **IPv6**

- b Press Enter to select **Next**.

If you selected IPv4, the Specify the management interface window appears. Go to [Step 9](#).

If you selected IPv6, the Autoconfigure window appears. Go to [Step 7](#).

**Step 7** Choose one of the following options:

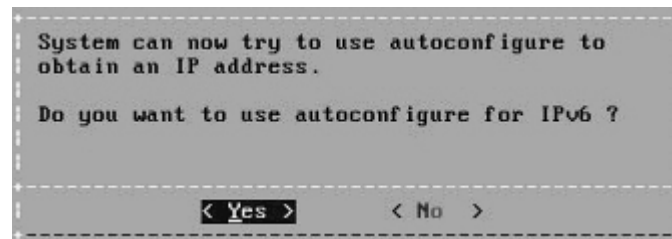

- a To automatically configure for IPv6, select **Yes**. Press Enter. The automatic configuration can take an extended period of time. When the automatic configuration is complete, the Specify a management interface window appears. Go to [Step 9](#).
- b To manually configure for IPv6, select **No**. Press Enter. Go to [Step 8](#). The Enter the IP address to use for IPv6 window appears.

```

Enter the IP address to use for IPv6
Use the up/down arrows to navigate between fields. Use the Tab key and
then the left/right arrow keys to select Next, back or Cancel, then
press Enter. Press ESC to cancel at anytime.

Host name:  strm.juniper.net
IP address:
Email server:

< Next >    < Back >    <Cancel>

```

- Step 8** To enter the IP address to use for IPv6:
- a Enter the values for the **Hostname**, **IP Address**, and **Email server**.
  - b Using the Tab key, select **Next**. Press Enter.

The Specify the management interface window appears.

```

Specify which is the management interface. If the interface has a link
(cable connected), a plus (+) is displayed before the description.

Use the up/down arrow keys to highlight another option and press the
spacebar to make the selection. Use the left/right arrow keys to select
Next, Back or Cancel, then press Enter. Press ESC to cancel at anytime.

Select management interface:

(*) eth0  +Ethernet HWaddr 00:0C:29:90:3F:24
( ) eth1  Ethernet HWaddr 00:0C:29:90:3F:2E
( ) eth2  Ethernet HWaddr 00:0C:29:90:3F:38
( ) lo    +Local Loopback
( ) sit0  IPv6-in-IPv4

< Next >    < Back >    <Cancel>

```

- Step 9** To specify a management interface:
- a Using the up/down arrow keys, highlight the interface you want to specify as the management interface and press the spacebar to select it.  
The plus (+) symbol indicates which interfaces have physical links.
  - b Press Enter to select **Next**.



**Note:** If you selected IPv6 as your Internet protocol, go to [Step 11](#).

The Configure STRM window appears.

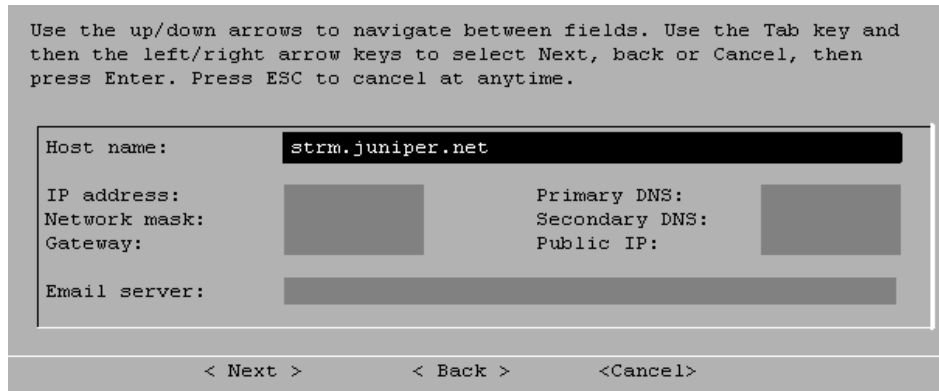

- Step 10** To configure the STRM network settings, using the up/down arrow keys to navigate the fields, enter values for the following parameters:
- **Hostname** - Specify a fully qualified domain name as the system hostname.
  - **IP Address** - Specify the IP address of the system.
  - **Network Mask** - Specify the network mask address for the system.
  - **Gateway** - Specify the default gateway of the system.
  - **Primary DNS** - Specify the primary DNS server address.
  - **Secondary DNS** - Optional. Specify the secondary DNS server address.
  - **Public IP** - Optional. Specify the Public IP address of the server. This is a secondary IP address that is used to access the server, usually from a different network or the Internet, and is managed by your network administrator. The Public IP address is often configured using Network Address Translation (NAT) services on your network or firewall settings on your network. NAT translates an IP address in one network to a different IP address in another network.
  - **Email Server** - Specify the e-mail server. If you do not have an e-mail server, specify **localhost** in this field.

**Step 11** Use the Tab key to move to the **Next** option. Press Enter.  
The New Root Password window appears.

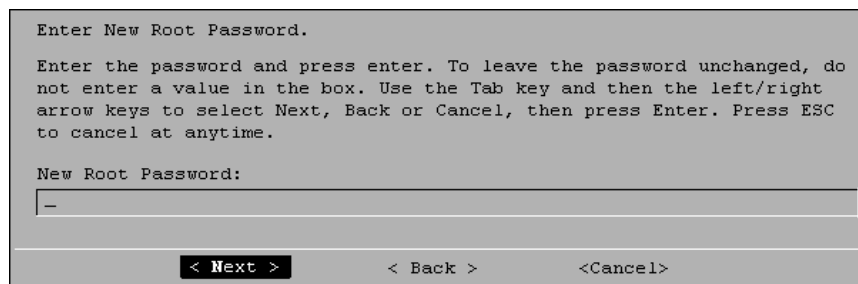

- Step 12** To configure the STRM root password:
- a Enter your password.

- b Use the Tab key to move to the **Next** option. Press Enter.  
The Confirm New Root Password window appears.

```

Confirm New Root Password.

Re-register the password and press enter. Use the Tab key and then the
left/right arrow keys to select Next, Back or Cancel, then press Enter.
Press ESC to cancel at anytime.

New Root Password (confirmation):
_____

<Finish>    < Back >    <Cancel>

```

- c Re-enter your new password to confirm.  
d Use the Tab key to move to the **Finish** option. Press Enter.  
A series of messages appear as STRM continues with the installation. This process typically takes several minutes.

The Configuration is Complete window appears.

**Step 13** Press Enter to select **OK**.

You are now ready to access STRM. For more information, see [Accessing STRM](#).

## Setting up Your Flow Appliance

To set up your Flow appliance:

**Step 1** To select the time zone continent:

- a Using the up/down arrow keys, or the page up/page down keys, select your time zone continent or area.  
b Press Enter to select **Next**.

The Time Zone Region window appears.

```

Select a time zone city or region.

Use the up/down arrow or the PgUp/PgDn keys to select a continent. Use
the left/right arrow keys to select a navigation option and press Enter.
Press ESC to cancel at anytime.

0 Adak (Aleutian Islands)
1 Anchorage (Alaska Time)
2 Anguilla
3 Antigua
4 Araguaina (Tocantins)
5 Argentina/Buenos_aires (Buenos Aires (BA, CF))
6 Argentina/Catamarca 9Catamarca (CT), Chubut (CH)
7 Argentina/Cordoba (most locations (CB, CC, CN, ER, FM, LP, MN, NQ
8 Argentina/Jujuy (Jujuy (JY))

< Next >    < Back >    <Cancel>

```



**Note:** The options that appear in this window are regions that are associated with the continent or area previously selected.

- c Using the up/down arrow keys, or the page up/page down keys, select your time zone region.  
d Press Enter to select **Next**.

The Choose which Internet protocol to use window appears.

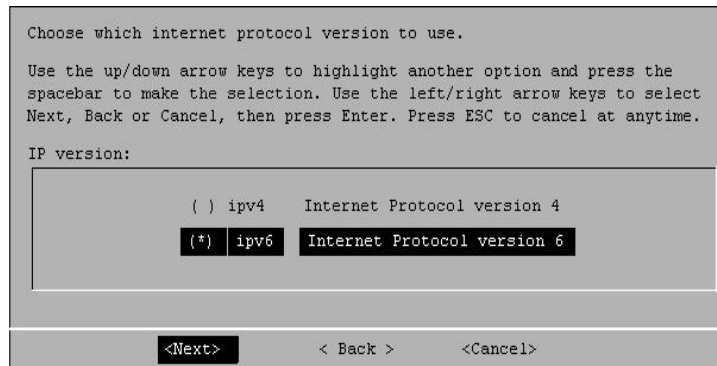

**Step 2** To select the Internet protocol:

a Using the up/down arrow keys, and then the spacebar, select one of the following options:

- IPv4
- IPv6

b Press Enter to select **Next**.

If you selected IPv4, the Specify the management interface window appears. Go to [Step 5](#).

If you selected IPv6, the Autoconfigure window appears. Go to [Step 3](#).

**Step 3** Choose one of the following options:

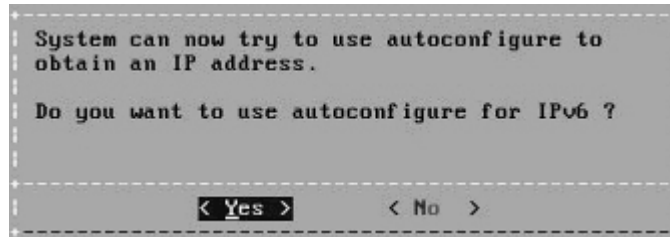

a To automatically configure for IPv6, select **Yes**. Press Enter. The automatic configuration can take an extended period of time. When the automatic configuration is complete, the Specify a management interface window appears. Go to [Step 5](#).

b To manually configure for IPv6, select **No**. Press Enter. Go to [Step 4](#).

The Enter the IP address to use for IPv6 window appears.

```

Enter the IP address to use for IPv6
Use the up/down arrows to navigate between fields. Use the Tab key and
then the left/right arrow keys to select Next, back or Cancel, then
press Enter. Press ESC to cancel at anytime.

```

Host name:	strm.juniper.net
IP address:	
Email server:	

- Step 4** To enter the IP address to use for IPv6:
- a Enter the values for the **Hostname**, **IP Address**, and **Email server**.
  - b Using the Tab key, select **Next**. Press Enter.

The Specify the management interface window appears.

```

Specify which is the management interface. If the interface has a link
(cable connected), a plus (+) is displayed before the description.
Use the up/down arrow keys to highlight another option and press the
spacebar to make the selection. Use the left/right arrow keys to select
Next, Back or Cancel, then press Enter. Press ESC to cancel at anytime.

```

Select management interface:

<input checked="" type="checkbox"/>	eth0	+Ethernet HWaddr 00:0C:29:90:3F:24
<input type="checkbox"/>	eth1	Ethernet HWaddr 00:0C:29:90:3F:2E
<input type="checkbox"/>	eth2	Ethernet HWaddr 00:0C:29:90:3F:38
<input type="checkbox"/>	lo	+Local Loopback
<input type="checkbox"/>	sit0	IPv6-in-IPv4

- Step 5** To specify a management interface:
- a Using the up/down arrow keys, highlight the interface you want to specify as the management interface and press the spacebar to select it.  
The plus (+) symbol indicates which interfaces have physical links.
  - b Press Enter to select **Next**.



**Note:** If you selected IPv6 as your Internet protocol, go to [Step 7](#).

The Configure STRM window appears.

Use the up/down arrows to navigate between fields. Use the Tab key and then the left/right arrow keys to select Next, back or Cancel, then press Enter. Press ESC to cancel at anytime.

Host name:	strm.juniper.net		
IP address:		Primary DNS:	
Network mask:		Secondary DNS:	
Gateway:		Public IP:	
Email server:			

< Next >      < Back >      <Cancel>

**Step 6** To configure the STRM network settings, using the up/down arrow keys to navigate the fields, enter values for the following parameters:

- **Hostname** - Specify a fully qualified domain name as the system hostname.
- **IP Address** - Specify the IP address of the system.
- **Network Mask** - Specify the network mask address for the system.
- **Gateway** - Specify the default gateway of the system.
- **Primary DNS** - Specify the primary DNS server address.
- **Secondary DNS** - Optional. Specify the secondary DNS server address.
- **Public IP** - Optional. Specify the Public IP address of the server. This is a secondary IP address that is used to access the server, usually from a different network or the Internet, and is managed by your network administrator. The Public IP address is often configured using Network Address Translation (NAT) services on your network or firewall settings on your network. NAT translates an IP address in one network to a different IP address in another network.
- **Email Server** - Specify the e-mail server. If you do not have an e-mail server, specify **localhost** in this field.

**Step 7** Use the Tab key to move to the **Next** option. Press Enter.

The New Root Password window appears.

Enter New Root Password.

Enter the password and press enter. To leave the password unchanged, do not enter a value in the box. Use the Tab key and then the left/right arrow keys to select Next, Back or Cancel, then press Enter. Press ESC to cancel at anytime.

New Root Password:

—

< Next >      < Back >      <Cancel>

**Step 8** To configure the STRM root password:

- a Enter your password.

- b Use the Tab key to move to the **Next** option. Press Enter.  
The Confirm New Root Password window appears.

```

Confirm New Root Password.

Re-register the password and press enter. Use the Tab key and then the
left/right arrow keys to select Next, Back or Cancel, then press Enter.
Press ESC to cancel at anytime.

New Root Password (confirmation):
_____

<Finish>    < Back >    <Cancel>

```

- c Re-enter your new password to confirm.  
d Use the Tab key to move to the **Finish** option. Press Enter.  
A series of messages appear as STRM continues with the installation. This process typically takes several minutes.

The Configuration is Complete window appears.

**Step 9** Press Enter to select **OK**.

You are now ready to access STRM. For more information, see [Accessing STRM](#).

## Accessing STRM

To access the STRM interface:

**Step 1** Open your web browser.

**Step 2** Log in to STRM:

`https://<IP Address>`

Where **<IP Address>** is the IP address of the STRM system. The default values are:

Username: **admin**

Password: **<root password>**

Where **<root password>** is the password assigned to STRM during the installation process.



**Note:** If you are using Mozilla Firefox 3.0, you must add an exception to Mozilla Firefox to log in to STRM. For more information, see your Mozilla documentation.

**Step 3** Click **Login To STRM**.

For your STRM Console, a default key provides you access to STRM for five weeks. For more information on the license key, see the *STRM Administration Guide*.



# A

## CHANGING NETWORK SETTINGS

This appendix provides information on changing network settings for the Console and non-Console systems including:

- [Changing Network Settings in an All-in-One Console](#)
- [Changing the Network Settings of a Console in a Multi-System Deployment](#)
- [Changing the Network Settings of a Non-Console in a Multi-System Deployment](#)

---

### Changing Network Settings in an All-in-One Console

You can change the network settings in your All-In-One system. An All-In-One system has all STRM components, including the Admin interface, installed on one system.

To change the settings on the STRM Console:



**Note:** You must have a local connection to your Console before executing the script.

**Step 1** Log in to the Console, as root.

**Step 2** Enter the following command:

```
qchange_netsetup
```

The Choose which Internet protocol to use window appears.

```
Choose which internet protocol version to use.
Use the up/down arrow keys to highlight another option and press the
spacebar to make the selection. Use the left/right arrow keys to select
Next, Back or Cancel, then press Enter. Press ESC to cancel at anytime.

IP version:
( ) ipv4   Internet Protocol version 4
(*) ipv6   Internet Protocol version 6

<Next>    < Back >    <Cancel>
```

**Step 3** To select the Internet protocol:

- a Using the up/down arrow keys, and then the spacebar, select one of the following options:
  - IPv4
  - IPv6
- b Press Enter to select **Next**.  
 If you selected IPv4, the Specify the management interface window appears. Go to [Step 6](#).  
 If you selected IPv6, the Autoconfigure window appears. Go to [Step 4](#).

**Step 4** Choose one of the following options:

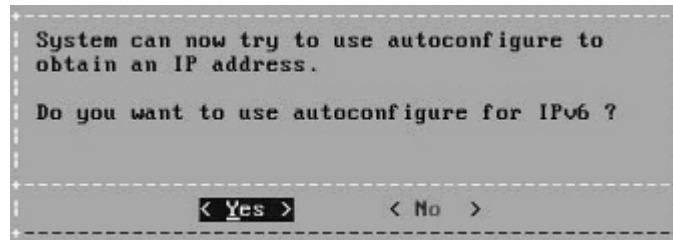

- a To automatically configure for IPv6, select **Yes**. Press Enter. The automatic configuration can take an extended period of time. When the automatic configuration is complete, the Specify a management interface window appears. Go to [Step 6](#).
- b To manually configure for IPv6, select **No**. Press Enter. Go to [Step 5](#).  
 The Enter the IP address to use for IPv6 window appears.

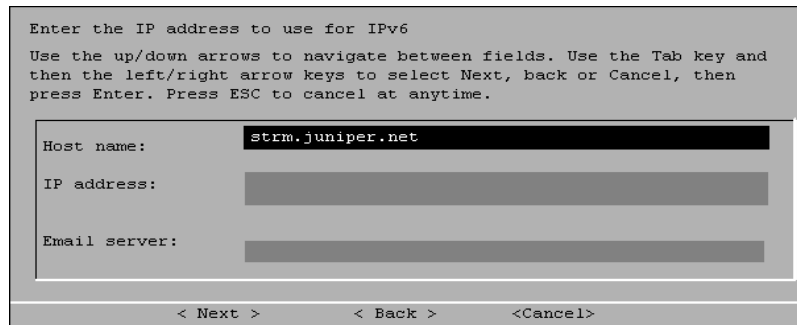

**Step 5** To enter the IP address to use for IPv6:

- a Enter the values for the **Hostname**, **IP Address**, and **Email server**.
- b Using the Tab key, select **Next**. Press Enter.  
 The Specify the management interface window appears.

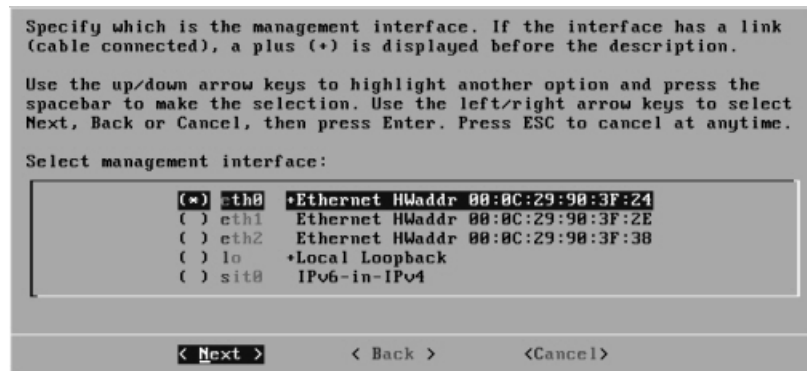

**Step 6** To specify a management interface:

- a Using the up/down arrow keys, highlight the interface you want to specify as the management interface and press the spacebar to select it.

The plus (+) symbol indicates which interfaces have physical links.

- b Press Enter to select **Next**.



**Note:** If you selected IPv6 as your Internet protocol, go to [Step 8](#).

The Configure STRM window appears.

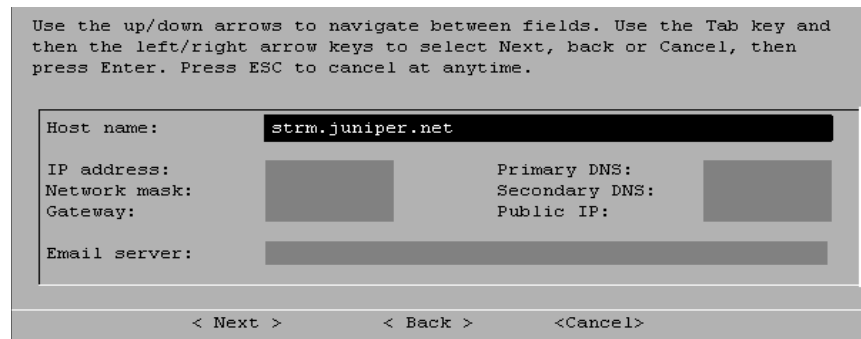

**Step 7** To configure the STRM network settings, using the up/down arrow keys to navigate the fields, enter values for the following parameters:

- **Hostname** - Specify a fully qualified domain name as the system hostname.
- **IP Address** - Specify the IP address of the system.
- **Network Mask** - Specify the network mask address for the system.
- **Gateway** - Specify the default gateway of the system.
- **Primary DNS** - Specify the primary DNS server address.
- **Secondary DNS** - Optional. Specify the secondary DNS server address.
- **Public IP** - Optional. Specify the Public IP address of the server. This is a secondary IP address that is used to access the server, usually from a different network or the Internet, and is managed by your network administrator. The Public IP address is often configured using Network Address Translation (NAT) services on your network or firewall settings on

your network. NAT translates an IP address in one network to a different IP address in another network.

- **Email Server** - Specify the e-mail server. If you do not have an e-mail server, specify **localhost** in this field.

**Step 8** Use the Tab key to navigate to the **Finish** option. Press Enter.

A series of messages appear as STRM processes the requested changes. After the requested changes are processed, the STRM system is automatically shutdown and rebooted.

---

## Changing the Network Settings of a Console in a Multi-System Deployment

To change the network settings in a multi-system deployment, you must remove all non-Console managed hosts from the deployment, change the network settings, re-add the managed host(s), and then re-assign the component(s).

You must perform this procedure in the following order:

- [Removing Non-Console Managed Hosts](#)
- [Changing the Network Settings](#)
- [Re-Adding Managed Host\(s\) and Re-Assigning the Components](#)



**Note:** This procedure requires you to use the deployment editor. For more information on using the deployment editor, see the *STRM Administration Guide*.

## Removing Non-Console Managed Hosts

To remove non-Console managed hosts from your deployment, you must:

**Step 1** Log in to STRM:

`https://<IP Address>`

Where `<IP Address>` is the IP address of the STRM system.

Username: **admin**

Password: **<admin password>**

**Step 2** In the main STRM interface, click the **Admin** tab.

The Admin interface appears.

**Step 3** Click the **Deployment Editor** icon.

The deployment editor appears.

**Step 4** Click the **System View** tab.

**Step 5** Select the managed host you want to delete.

**Step 6** Use the right mouse button (right-click) to access the menu, select **Remove host**.

Repeat for each non-Console managed host until all hosts are deleted.

**Step 7** Click **Save**.

**Step 8** Close the deployment editor.

**Step 9** From the Admin interface, click **Deploy Changes**.

The changes are deployed.

### Changing the Network Settings

To change the network settings, you must:

**Step 1** Log in to the Console as root.

**Step 2** Enter the following command:

```
qchange_netsetup
```

The Choose which Internet protocol to use window appears.

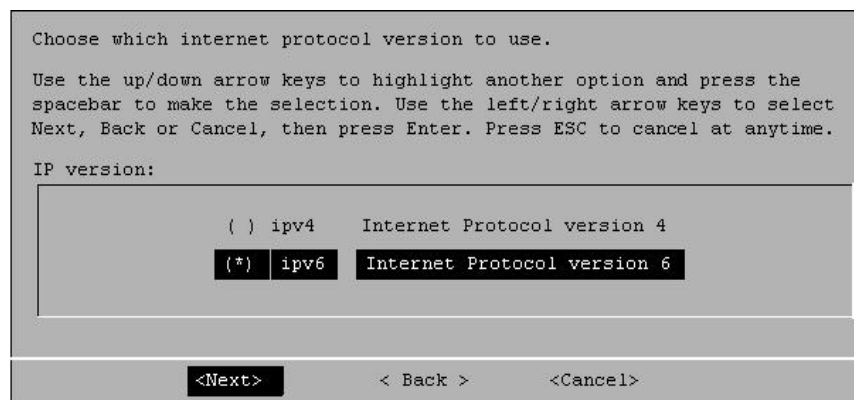

**Step 3** To select the Internet protocol:

**a** Using the up/down arrow keys, and then the spacebar, select one of the following options:

- IPv4
- IPv6

**b** Press Enter to select **Next**.

If you selected IPv4, the Specify the management interface window appears. Go to [Step 6](#).

If you selected IPv6, the Autoconfigure window appears. Go to [Step 4](#).

**Step 4** Choose one of the following options:

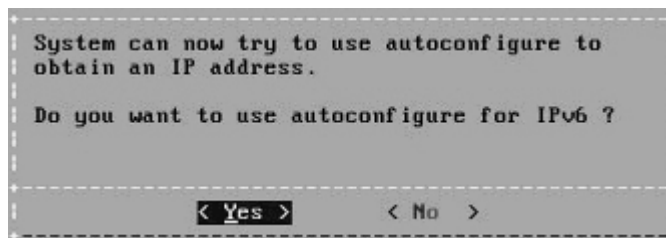

**a** To automatically configure for IPv6, select **Yes**. Press Enter. The automatic configuration can take an extended period of time. When the automatic

configuration is complete, the Specify a management interface window appears. Go to [Step 6](#).

- b To manually configure for IPv6, select **No**. Press Enter. Go to [Step 5](#).  
The Enter the IP address to use for IPv6 window appears.

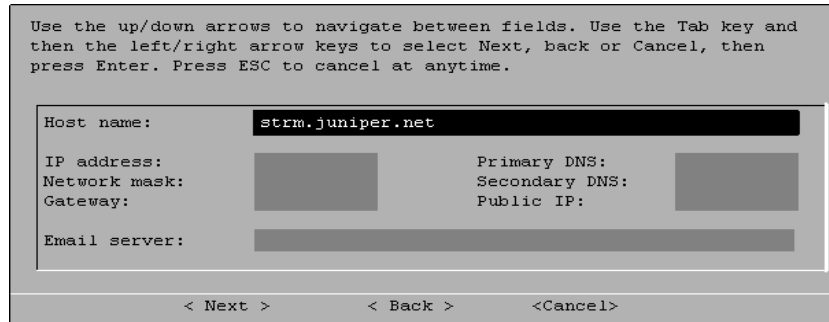

**Step 5** To enter the IP address to use for IPv6:

- a Enter the values for the **Hostname**, **IP Address**, and **Email server**.
- b Using the Tab key, select **Next**. Press Enter.

The Specify the management interface window appears.

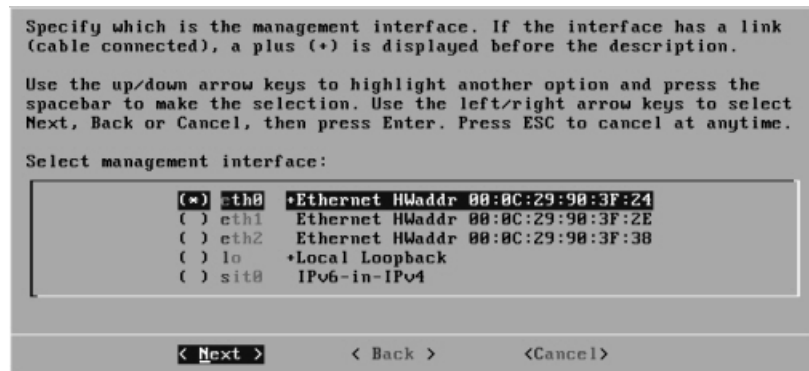

**Step 6** To specify a management interface:

- a Using the up/down arrow keys, highlight the interface you want to specify as the management interface and press the spacebar to select it.  
The plus (+) symbol indicates which interfaces have physical links.
- b Press Enter to select **Next**.



**Note:** If you selected IPv6 as your Internet protocol, go to [Step 8](#).

The Configure STRM window appears.

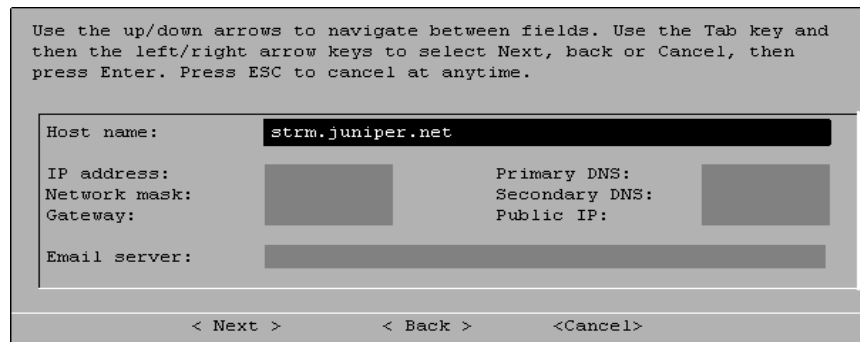

**Step 7** To configure the STRM network settings, using the up/down arrow keys to navigate the fields, enter values for the following parameters:

- **Hostname** - Specify a fully qualified domain name as the system hostname.
- **IP Address** - Specify the IP address of the system.
- **Network Mask** - Specify the network mask address for the system.
- **Gateway** - Specify the default gateway of the system.
- **Primary DNS** - Specify the primary DNS server address.
- **Secondary DNS** - Optional. Specify the secondary DNS server address.
- **Public IP** - Optional. Specify the Public IP address of the server. This is a secondary IP address that is used to access the server, usually from a different network or the Internet, and is managed by your network administrator. The Public IP address is often configured using Network Address Translation (NAT) services on your network or firewall settings on your network. NAT translates an IP address in one network to a different IP address in another network.
- **Email Server** - Specify the e-mail server. If you do not have an e-mail server, specify **localhost** in this field.

**Step 8** Use the Tab key to move to the **Finish** option. Press Enter.

A series of messages appear as STRM processes the requested changes. After the requested changes are processed, the STRM system is automatically shutdown and rebooted.

### Re-Adding Managed Host(s) and Re-Assigning the Components

To re-add the managed host(s) and re-assign component(s), you must:

**Step 1** Log in to STRM:

`https://<IP Address>`

Where **<IP Address>** is the IP address of the STRM system.

Username: **admin**

Password: **<admin password>**

**Step 2** In the main STRM Interface, click the **Admin** tab.

The Admin interface appears.

**Step 3** Click the **Deployment Edit** icon.

The deployment editor appears.

**Step 4** Click the **System View** tab.

**Step 5** From the menu, select **Actions > Add a managed host**.

The Add a new host wizard appears.

**Step 6** Click **Next**.

The Enter the host's IP window appears.

**Step 7** Enter values for the parameters:

- **Enter the IP of the server or appliance to add** - Specify the IP address of the host you want to add to your System View.
- **Enter the root password of the host** - Specify the root password for the host.
- **Confirm the root password of the host** - Specify the password again, for confirmation.
- **Host is NATed** - Select if you want to specify NAT values if necessary.
- **Enable Encryption** - Select if you want to enable encryption.

**Step 8** Click **Next**.

**Step 9** Click **Finish**.

**Step 10** Re-assign all components to your non-Console managed host.

- a In the STRM deployment editor, click the **Event View** tab.
- b Select the component you want to re-assign to the managed host.
- c From the menu, select **Actions > Assign**



**Note:** You can also use the right mouse button (right-click) to access the Actions menu items.

The Assign Component wizard appears.

- d From the **Select a host** drop-down list box, select the host you want to re-assign to this component. Click **Next**.
- e Click **Finish**.

**Step 11** Repeat for each non-Console managed host until all hosts are re-added and re-assigned.

**Step 12** Close the deployment editor.

**Step 13** From the Admin interface, click **Deploy Changes**.

The changes are deployed.

## Changing the Network Settings of a Non-Console in a Multi-System Deployment

To change the network settings of a non-Console in a multi-system deployment, you must remove all non-Console managed host from the deployment, change the network settings, re-add the managed host, and then re-assign the component(s).

You must perform this procedure in the following order:

- [Removing the Non-Console Managed Host](#)
- [Changing the Network Settings](#)
- [Re-Adding the Managed Host and Re-Assigning the Components](#)



**Note:** This procedure requires you to use the deployment editor. For more information on using the deployment editor, see the *STRM Administration Guide*.

### Removing the Non-Console Managed Host

To remove non-Console managed host from your deployment, you must:

**Step 1** Log in to STRM:

`https://<IP Address>`

Where `<IP Address>` is the IP address of the STRM system.

Username: **admin**

Password: **<admin password>**

**Step 2** In the main STRM Interface, click the **Admin** tab.

The Admin interface appears.

**Step 3** Click the **Deployment Editor** icon.

The deployment editor appears.

**Step 4** Click the **System View** tab.

**Step 5** Select the managed host you want to delete.

**Step 6** Use the right mouse button (right-click) to access the menu, select **Remove host**.

**Step 7** Close the deployment editor.

**Step 8** From the Admin interface, click **Deploy Changes**.

The changes are deployed.

### Changing the Network Settings

To change the network settings, you must:

**Step 1** Log in to the non-Console as root.

**Step 2** Enter the following command:

`qchange_netsetup`

The Choose which Internet protocol to use window appears.

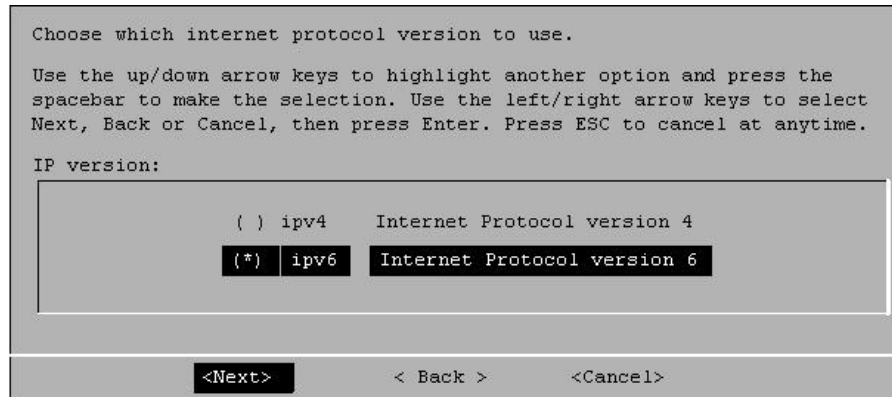

**Step 3** To select the Internet protocol:

a Using the up/down arrow keys, and then the spacebar, select one of the following options:

- IPv4
- IPv6

b Press Enter to select **Next**.

If you selected IPv4, the Specify the management interface window appears. Go to [Step 6](#).

If you selected IPv6, the Autoconfigure window appears. Go to [Step 4](#).

**Step 4** Choose one of the following options:

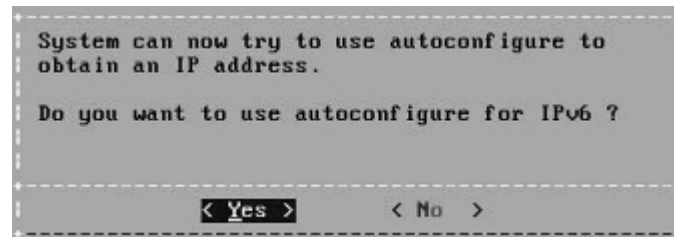

a To automatically configure for IPv6, select **Yes**. Press Enter. The automatic configuration can take an extended period of time. When the automatic configuration is complete, the Specify a management interface window appears. Go to [Step 6](#).

b To manually configure for IPv6, select **No**. Press Enter. Go to [Step 5](#).

The Enter the IP address to use for IPv6 window appears.

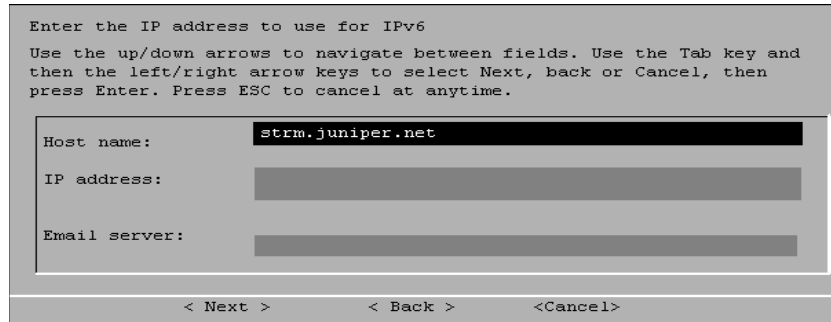

- Step 5** To enter the IP address to use for IPv6:
- a Enter the values for the **Hostname**, **IP Address**, and **Email server**.
  - b Using the Tab key, select **Next**. Press Enter.

The Specify the management interface window appears.

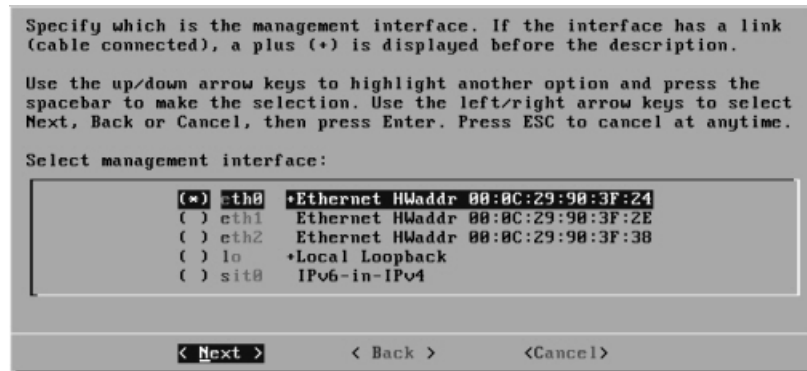

- Step 6** To specify a management interface:
- a Using the up/down arrow keys, highlight the interface you want to specify as the management interface and press the spacebar to select it.  
The plus (+) symbol indicates which interfaces have physical links.
  - b Press Enter to select **Next**.



**Note:** If you selected IPv6 as your Internet protocol, go to [Step 8](#).

The Configure STRM window appears.

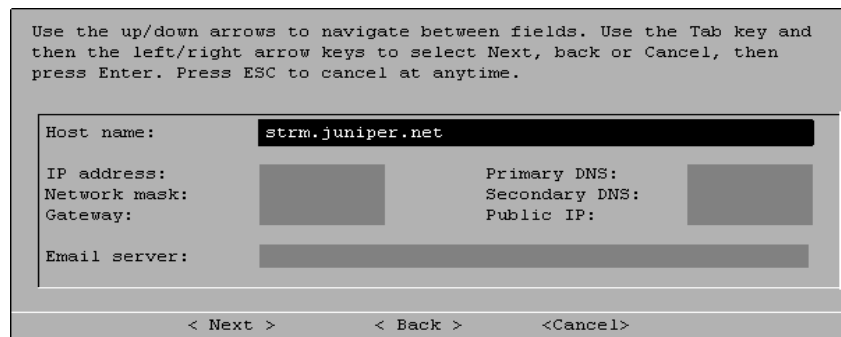

- Step 7** To configure the STRM network settings, using the up/down arrow keys to navigate the fields, enter values for the following parameters:
- **Hostname** - Specify a fully qualified domain name as the system hostname.
  - **IP Address** - Specify the IP address of the system.
  - **Network Mask** - Specify the network mask address for the system.
  - **Gateway** - Specify the default gateway of the system.
  - **Primary DNS** - Specify the primary DNS server address.
  - **Secondary DNS** - Optional. Specify the secondary DNS server address.
  - **Public IP** - Optional. Specify the Public IP address of the server. This is a secondary IP address that is used to access the server, usually from a different network or the Internet, and is managed by your network administrator. The Public IP address is often configured using Network Address Translation (NAT) services on your network or firewall settings on your network. NAT translates an IP address in one network to a different IP address in another network.
  - **Email Server** - Specify the e-mail server. If you do not have an e-mail server, specify **localhost** in this field.

- Step 8** Use the Tab key to move to the **Finish** option. Press Enter.

A series of messages appear as STRM processes the requested changes. After the requested changes are processed, the STRM system is automatically shutdown and rebooted.

### Re-Adding the Managed Host and Re-Assigning the Components

To re-add the managed host and re-assign component(s), you must:

- Step 1** Log in to STRM:  
`https://<IP Address>`  
 Where **<IP Address>** is the IP address of the STRM system.  
 Username: **admin**  
 Password: **<admin password>**
- Step 2** In the main STRM Interface, click the **Admin tab**.  
 The Admin interface appears.
- Step 3** Click the **Deployment Editor** icon.  
 The deployment editor appears.
- Step 4** Click the **System View** tab.
- Step 5** From the menu, select **Actions > Add a managed host**.  
 The Add a new host wizard appears.
- Step 6** Click **Next**.

The Enter the host's IP window appears.

**Step 7** Enter values for the parameters:

- **Enter the IP of the server or appliance to add** - Specify the IP address of the host you want to add to your System View.
- **Enter the root password of the host** - Specify the root password for the host.
- **Confirm the root password of the host** - Specify the password again, for confirmation.
- **Host is NATed** - Select if you want to specify NAT values if necessary.
- **Enable Encryption** - Select if you want to enable encryption.

**Step 8** Click **Next**.

**Step 9** Click **Finish**.

**Step 10** Re-assign all components to your non-Console managed host.

- a In the STRM deployment editor, click the **Event View** tab.
- b Select the component you want to re-assign to the managed host.
- c From the menu, select **Actions > Assign**.



**Note:** You can also use the right mouse button (right-click) to access the Actions menu items.

The Assign Component wizard appears.

- d From a Select a host drop-down list box, select the host you want to re-assign to this component. Click **Next**.
- e Click **Finish**.

**Step 11** Close the deployment editor.

**Step 12** From the Admin interface, click **Deploy Changes**.

The changes are deployed.



# C

## REINSTALLING STRM

This appendix provides information about reinstalling STRM software from the recovery partition. When you re-install STRM, your system will be restored back to factory default configuration, meaning that your current configuration and data files will be overwritten.



**Note:** *This appendix only applies to fresh STRM 2009.1 installations or upgrades from fresh STRM 2008.3 installations on systems using CentOS; it does not apply to appliances that have been upgraded from a previous release or systems using Red Hat Enterprise Linux.*

This appendix includes:

- [About the Recovery Partition](#)
- [Reinstalling STRM](#)

---

### About the Recovery Partition

When you install STRM 2009.1, the installer (ISO) is copied into the recovery partition. From this partition, you can re-install STRM, which restores STRM to factory defaults.



**Note:** *Any software upgrades you perform after you install STRM 2009.1 will replace the ISO file with newer version.*

Whenever you reboot your STRM appliance, you will be presented with the option to re-install the software. If you do not respond to the prompt after 5 seconds, the system will reboot as normal, thus maintaining your configuration and data files. If you choose the re-install STRM, a warning message appears and you must confirm that you want to re-install STRM. After confirmation, the installer is run and you can follow the prompts through the installation process.



**Note:** *After a hard disk failure, you will be unable to re-install from the recovery partition, because it will no longer be available. If you experience a hard disk failure, contact Customer Support for assistance.*

**Reinstalling STRM**

This section includes:

- [Preparing for Reinstallation](#)
- [Reinstalling on a STRM Appliance](#)
- [Reinstalling on a Flow Appliance](#)

**Preparing for Reinstallation**

To prepare for re-installation:

**Step 1** Reboot your STRM appliance.

A menu appears with the following options:

- Normal System - Starts STRM as normal.
- Factory re-install - Runs the installer.

**Step 2** Select **Factory reinstall**.

The installer runs and detects that there is already an installation present.

**Step 3** Enter `f1atten` to continue.

The installer repartitions and reformats the hard disk, installs the OS, and then reinstalls STRM. Wait for the flatten process to complete. This process can take up to several minutes, depending on your system. When the process is complete, the following appears:

```
OK: qsetup is completed.
```

```
Type HALT to shutdown or SETUP to login and configure system
```

**Step 4** Enter `SETUP`.

**Step 5** Log in to STRM as root.

**Step 6** Press Enter.

The End User License Agreement (EULA) appears.

**Step 7** Read the information in the window. Press the Spacebar to advance each window until you have reached the end of the document. Type **yes** to accept the agreement, and then press Enter.

The activation key window appears. The activation key is a 24-digit, four-part (separated by hyphens), alphanumeric string that you receive from Juniper Networks.

You can find the key:

- Printed on a sticker and physically placed on your appliance.
- Included with the packing slip; appliances are listed along with their associated keys.

**Step 8** Enter your activation key and press Enter.



**Note:** The letter *l* and the number *1* (one) are treated the same, as are the letter *O* and the number *0* (zero).

If you are setting up a STRM appliance, such as a STRM 2100, the Tuning Template window appears. Go to [Reinstalling on a STRM Appliance](#).

If you are setting up a Flow Collector appliance, such as a Flow 1101, the Time Zone Continent window appears. Go to [Reinstalling on a Flow Appliance](#).

## Reinstalling on a STRM Appliance

To re-install on a STRM appliance:

**Step 1** To select a tuning template:

- a Using the up/down arrow keys, select one of the following tuning templates:
  - **Enterprise** - Tunes properties for internal network activity.
  - **University** - Tunes properties for education-specific concerns.



**Note:** For more information about each template, see the *STRM Administration Guide*.

- b Press Enter to select **Next**.

The Set the Date and Time window appears.

**Step 2** Using the up/down arrow keys, highlight the method you want to use to set the date and time, then use the spacebar to select that option:

- **Manual** - Allows you to manually input the time and date. Use the Tab key to select the **Next** option. Press Enter. The Current Date and Time window appears. Go to [Step 3](#).
- **Server** - Allows you to specify your time server. Use the Tab key to select the **Next** option. Press Enter. The Enter Time Server window appears. Go to [Step 4](#).

**Step 3** To manually enter the time and date:

- a Enter the current date and time.
- b Using the Tab key, select **Next**, and then press Enter.
- c Go to [Step 5](#).

**Step 4** To specify a time server:

- a In the text field, enter the time server name or IP address.
- b Using the Tab key, select **Next**, and then press Enter.

The Time Zone Continent window appears.

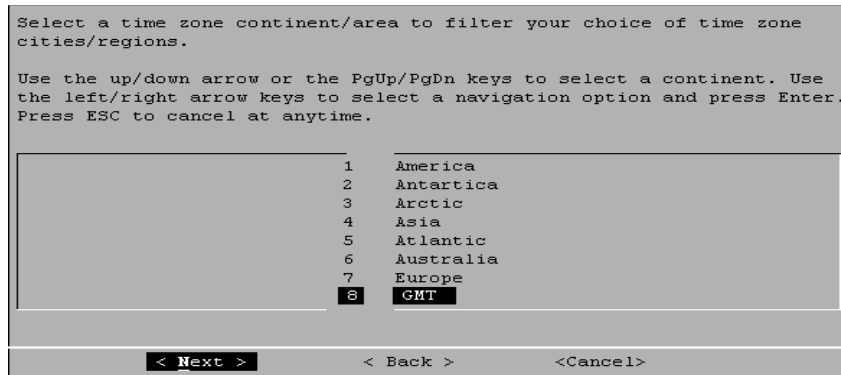

**Step 5** To select the time zone continent:

- a Using the up/down arrow keys, or the page up/page down keys, select your time zone continent or area.
- b Press Enter to select **Next**.

The Time Zone Region window appears.

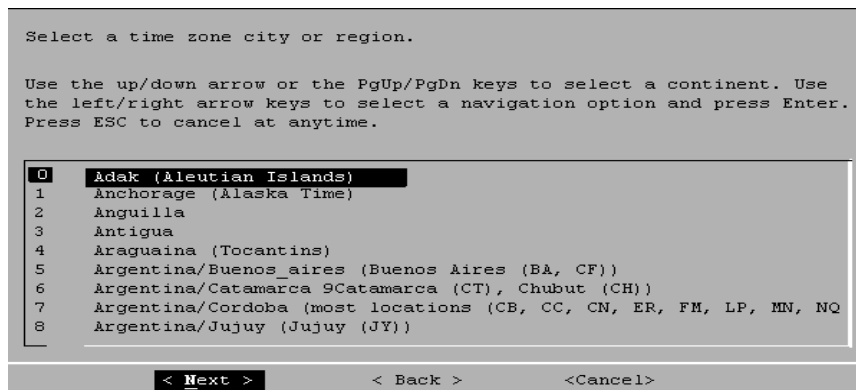

**Note:** The options that appear in this window are regions that are associated with the continent or area previously selected.

- c Using the up/down arrow keys, or the page up/page down keys, select your time zone region.
- d Press Enter to select **Next**.

The Choose which Internet protocol to use window appears.

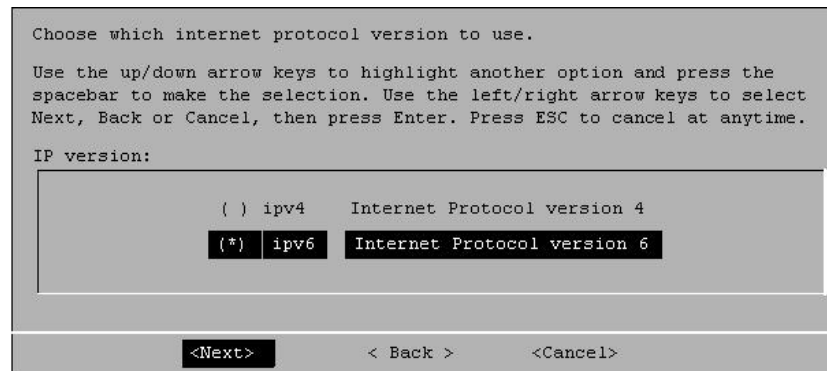

**Step 6** To select the Internet protocol:

- a Using the up/down arrow keys, and then the spacebar, select one of the following options:
  - **IPv4**
  - **IPv6**
- b Press Enter to select **Next**.

If you selected IPv4, the Specify the management interface window appears. Go to [Step 9](#).

If you selected IPv6, the Autoconfigure window appears. Go to [Step 7](#).

**Step 7** Choose one of the following options:

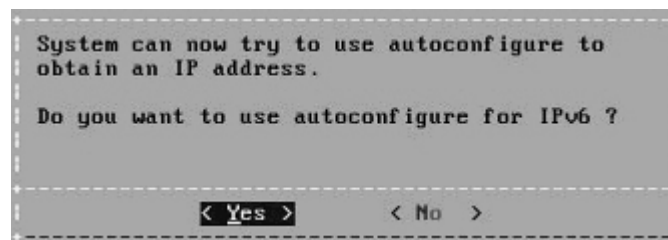

- a To automatically configure for IPv6, select **Yes**. Press Enter. The automatic configuration can take an extended period of time. When the automatic configuration is complete, the Specify a management interface window appears. Go to [Step 9](#).
- b To manually configure for IPv6, select **No**. Press Enter. Go to [Step 8](#). The Enter the IP address to use for IPv6 window appears.

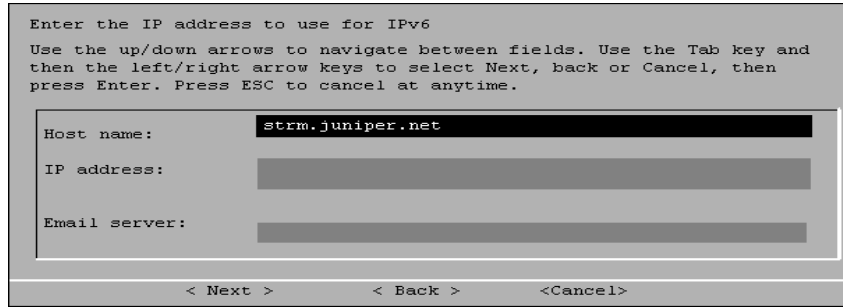

- Step 8** To enter the IP address to use for IPv6:
- a Enter the values for the **Hostname**, **IP Address**, and **Email server**.
  - b Using the Tab key, select **Next**. Press Enter.

The Specify the management interface window appears.

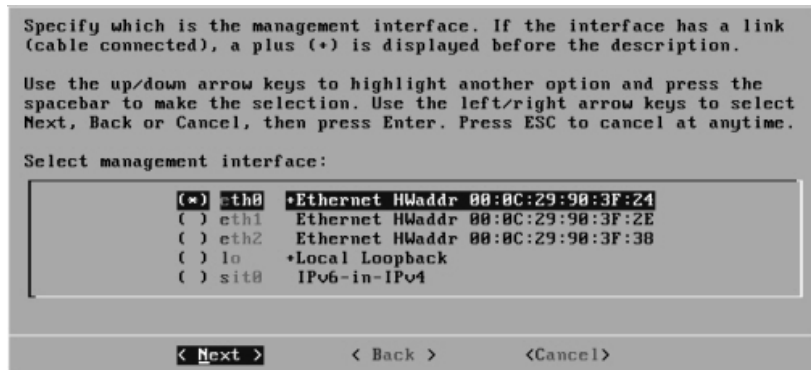

- Step 9** To specify a management interface:
- a Using the up/down arrow keys, highlight the interface you want to specify as the management interface and press the spacebar to select it.  
The plus (+) symbol indicates which interfaces have physical links.
  - b Press Enter to select **Next**.



**Note:** If you selected IPv6 as your Internet protocol, go to [Step 11](#).

The Configure STRM window appears.

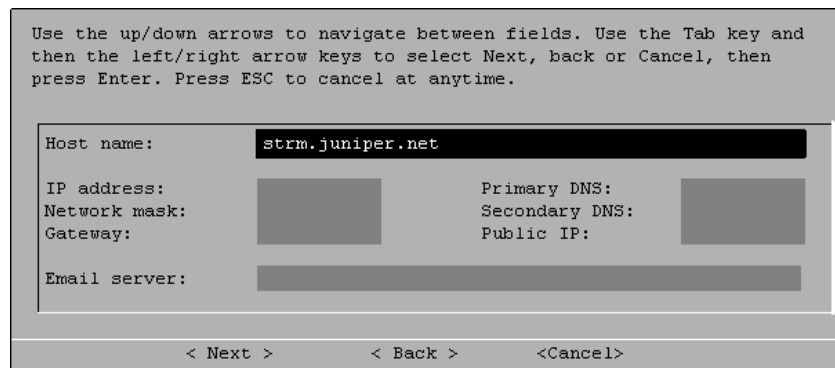

**Step 10** To configure the STRM network settings, using the up/down arrow keys to navigate the fields, enter values for the following parameters:

- **Hostname** - Specify a fully qualified domain name as the system hostname.
- **IP Address** - Specify the IP address of the system.
- **Network Mask** - Specify the network mask address for the system.
- **Gateway** - Specify the default gateway of the system.
- **Primary DNS** - Specify the primary DNS server address.
- **Secondary DNS** - Optional. Specify the secondary DNS server address.
- **Public IP** - Optional. Specify the Public IP address of the server. This is a secondary IP address that is used to access the server, usually from a different network or the Internet, and is managed by your network administrator. The Public IP address is often configured using Network Address Translation (NAT) services on your network or firewall settings on your network. NAT translates an IP address in one network to a different IP address in another network.
- **Email Server** - Specify the e-mail server. If you do not have an e-mail server, specify **localhost** in this field.

**Step 11** Use the Tab key to move to the **Next** option. Press Enter.

The New Root Password window appears.

Enter New Root Password.

Enter the password and press enter. To leave the password unchanged, do not enter a value in the box. Use the Tab key and then the left/right arrow keys to select Next, Back or Cancel, then press Enter. Press ESC to cancel at anytime.

New Root Password:

-

< Next >      < Back >      <Cancel>

**Step 12** To configure the STRM root password:

- a Enter your password.
- b Use the Tab key to move to the **Next** option. Press Enter.

The Confirm New Root Password window appears.

Confirm New Root Password.

Re-register the password and press enter. Use the Tab key and then the left/right arrow keys to select Next, Back or Cancel, then press Enter. Press ESC to cancel at anytime.

New Root Password (confirmation):

-

<Finish>      < Back >      <Cancel>

- c Re-enter your new password to confirm.
- d Use the Tab key to move to the **Finish** option. Press Enter.

A series of messages appear as STRM continues with the installation. This process typically takes several minutes.

The Configuration is Complete window appears.

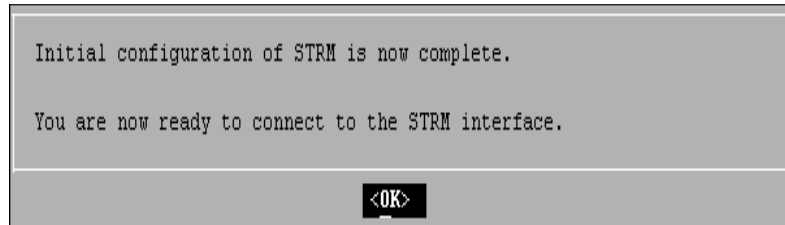

- Step 13** Press Enter to select **OK**.  
 You are now ready to access STRM.

**Reinstalling on a Flow Appliance** To re-install on a Flow appliance:

- Step 1** To select the time zone continent:
- a Using the up/down arrow keys, or the page up/page down keys, select your time zone continent or area.
  - b Press Enter to select **Next**.

The Time Zone Region window appears.

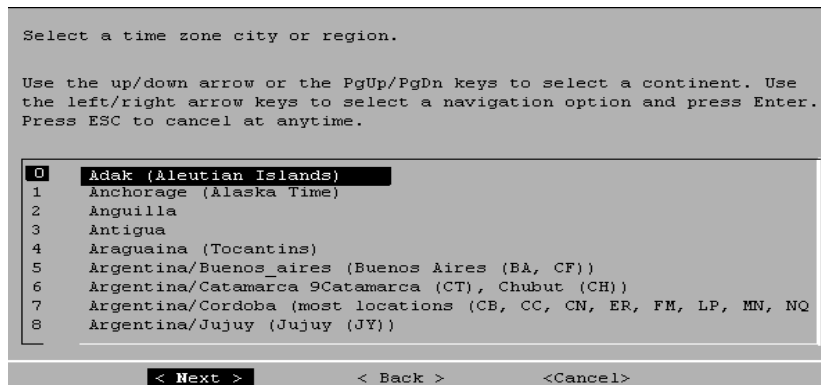

**Note:** The options that appear in this window are regions that are associated with the continent or area previously selected.

- c Using the up/down arrow keys, or the page up/page down keys, select your time zone region.
- d Press Enter to select **Next**.

The Choose which Internet protocol to use window appears.

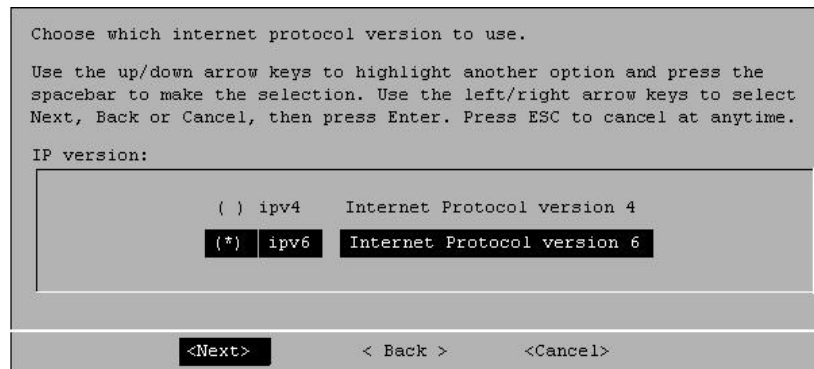

**Step 2** To select the Internet protocol:

- a Using the up/down arrow keys, and then the spacebar, select one of the following options:
  - **IPv4**
  - **IPv6**
- b Press Enter to select **Next**.  
 If you selected IPv4, the Specify the management interface window appears. Go to [Step 5](#).  
 If you selected IPv6, the Autoconfigure window appears. Go to [Step 3](#).

**Step 3** Choose one of the following options:

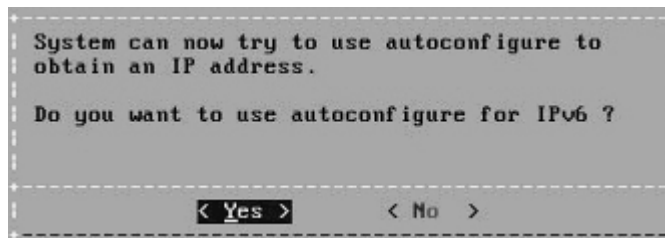

- a To automatically configure for IPv6, select **Yes**. Press Enter. The automatic configuration can take an extended period of time. When the automatic configuration is complete, the Specify a management interface window appears. Go to [Step 5](#).
- b To manually configure for IPv6, select **No**. Press Enter. Go to [Step 4](#).  
 The Enter the IP address to use for IPv6 window appears.

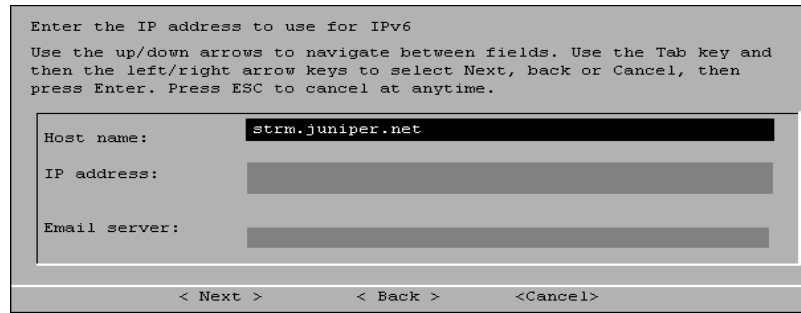

- Step 4** To enter the IP address to use for IPv6:
- a Enter the values for the **Hostname**, **IP Address**, and **Email server**.
  - b Using the Tab key, select **Next**. Press Enter.

The Specify the management interface window appears.

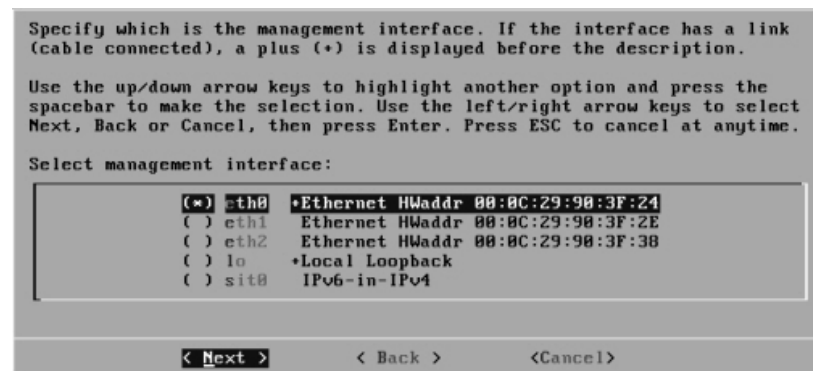

- Step 5** To specify a management interface:
- a Using the up/down arrow keys, highlight the interface you want to specify as the management interface and press the spacebar to select it.  
The plus (+) symbol indicates which interfaces have physical links.
  - b Press Enter to select **Next**.



**Note:** If you selected IPv6 as your Internet protocol, go to [Step 7](#).

The Configure STRM window appears.

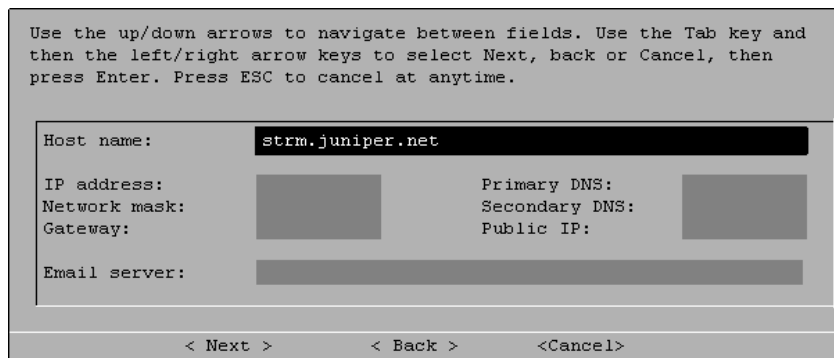

**Step 6** To configure the STRM network settings, using the up/down arrow keys to navigate the fields, enter values for the following parameters:

- **Hostname** - Specify a fully qualified domain name as the system hostname.
- **IP Address** - Specify the IP address of the system.
- **Network Mask** - Specify the network mask address for the system.
- **Gateway** - Specify the default gateway of the system.
- **Primary DNS** - Specify the primary DNS server address.
- **Secondary DNS** - Optional. Specify the secondary DNS server address.
- **Public IP** - Optional. Specify the Public IP address of the server. This is a secondary IP address that is used to access the server, usually from a different network or the Internet, and is managed by your network administrator. The Public IP address is often configured using Network Address Translation (NAT) services on your network or firewall settings on your network. NAT translates an IP address in one network to a different IP address in another network.
- **Email Server** - Specify the e-mail server. If you do not have an e-mail server, specify **localhost** in this field.

**Step 7** Use the Tab key to navigate to the **Finish** option. Press Enter.

The New Root Password window appears.

Enter New Root Password.

Enter the password and press enter. To leave the password unchanged, do not enter a value in the box. Use the Tab key and then the left/right arrow keys to select Next, Back or Cancel, then press Enter. Press ESC to cancel at anytime.

New Root Password:

-

< Next >      < Back >      <Cancel>

**Step 8** To configure the STRM root password:

- a Enter your password.
- b Use the Tab key to move to the **Next** option. Press Enter.

The Confirm New Root Password window appears.

Confirm New Root Password.

Re-register the password and press enter. Use the Tab key and then the left/right arrow keys to select Next, Back or Cancel, then press Enter. Press ESC to cancel at anytime.

New Root Password (confirmation):

-

<Finish>      < Back >      <Cancel>

- c Re-enter your new password to confirm.
- d Use the Tab key to move to the **Finish** option. Press Enter.

A series of messages appear as STRM continues with the installation. This process typically takes several minutes.

The Configuration is Complete window appears.

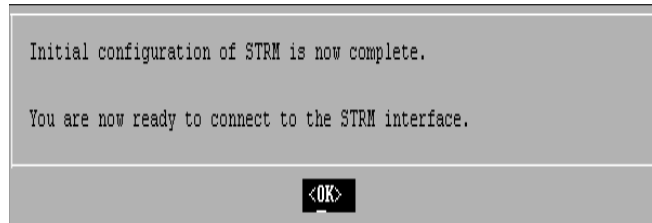

**Step 9** Press Enter to select **OK**.

You are now ready to access STRM.

# INDEX

---

## A

about this guide 1  
appliances  
    setting-up 9

---

## B

browser support 6

---

## C

Classification Engine  
    definition 4  
Console  
    definition 4  
conventions 1

---

## E

Event Collector  
    definition 4  
Event Processor  
    definition 4

---

## F

Flow Processor  
    definition 4  
Flow Writer  
    definition 4

---

## H

hardware requirements 5

---

## I

installing  
    preparing 3  
installing STRM 9

---

## M

Magistrate  
    definition 4

---

## N

network hierarchy  
    preparing 6

---

## network settings

all-in-one Console 21  
changing 21  
Console in a multi-system deployment 24  
identifying 7  
non-Console in a multi-system deployment 29

---

## P

preparing  
    installation 3  
preparing your network hierarchy 6

---

## Q

QFlow Collector  
    definition 4

---

## R

recovery partition 35  
re-installing STRM 35  
requirements  
    hardware 5  
    software 5

---

## S

security monitoring devices  
    identifying 7  
software requirements 5

---

## U

Update Daemon  
    definition 4

