

## Chapter 5

# Configuring NMC-RX Application Settings

This chapter describes how to configure NMC-RX application settings and contains the following sections:

- Overview on page 61
- Configuring Config Sync Services on page 62
- Configuring the Polling Service on page 67
- Configuring Remote Login Settings on page 68
- Configuring User Authentication Settings on page 69
- Configuring the User Inactivity Timer on page 72
- Configuring Software Download Settings on page 73

## Overview

---

You can configure the following application settings by choosing NMC-RX Application Settings from the Configuration menu:

- Config Sync Services
- Polling Service
- Remote Login
- NMC-RX User Authentication
- User Inactivity Timer
- Software Download



**NOTE:** You may need security privileges to set or configure some of these application settings. Refer to each section for specific details.

---

## Configuring Config Sync Services

Config Sync Services provide device discovery services, software download services, and task scheduling services. For a Config Sync Service to discover a device on your network, you must create the device in the NMC-RX application using the network IP address of the device. When you create a new device using the NMC-RX application, the Config Sync Service goes out to the device and obtains information about it.

The NMC-RX application uses a distributed processing model to provide greater scalability and control of discovery and update processes for E-series devices (see Figure 13).

**Figure 13: Sample Config Sync Services Distribution**

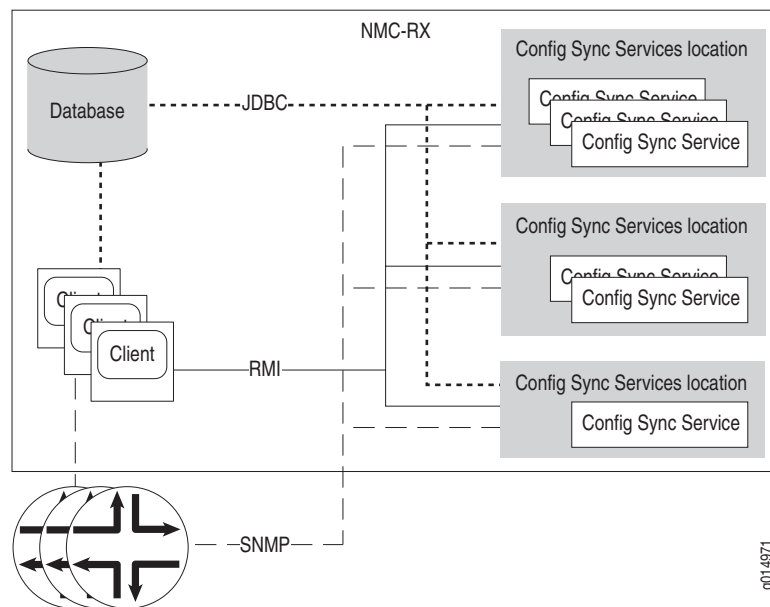

A Config Sync Services pool allows multiple Config Sync Services to be active simultaneously, thus providing a wealth of processing power that is available to multiple Config Sync Services locations. During installation, a system administrator can choose to install one or more Config Sync Services on a workstation without having to install the other NMC-RX components.

You can run multiple Config Sync Services on a single platform or utilize multiple platforms as part of the same NMC-RX Config Sync Services pool. You can oversee and manage the distributed Config Sync Services pool using the NMC-RX client application.



**NOTE:** An FTP user must be set up and running correctly for the NMC-RX application to use the Config Sync Services.



**NOTE:** Only users with a security privilege can configure Config Sync Services. For more information, see *Chapter 9, Configuring Security Settings*.

To configure Config Sync Services:

1. From the Configuration menu in either the Network Workshop or the Device Workshop, choose NMC-RX Application Settings, and then click Config Sync Services.

The Config Sync Services tab appears.

Config Sync Services | Polling Service | Remote Login | NMC-RX User Authentication | User Inactivity Timer | Software Download

SNMP Settings User Profile:

Config Sync Services:

Service ID	Location	Start Time	Status
1	10.10.120.237	2005-02-23 09:08	Available
2	10.10.120.237	2005-02-23 09:08	Available
3	10.10.120.237	2005-02-23 09:08	Available
4	10.10.120.237	2005-02-23 09:08	Available
5	10.10.120.237	2005-02-23 09:08	Available
6			Not Installed
7			Not Installed
8			Not Installed
9			Not Installed
10			Not Installed

Config Sync Service:

RMI Registry Port:  Scheduler MAX Operations:

FTP Destinations:

FTP Destination: (Discovery & Staging)

FTP Settings:

Login:  IP Address:

Password:  Sub Directory:

Re-enter Password:  FTP Timeout (sec):

Local Root Directory:  Local Sub Directory:

When you select a service in the Config Sync Services table, the values for the Config Sync Service parameters are automatically populated. The parameters are disabled for a Config Sync Service whose status is Not Installed.

The RMI Registry Port, Scheduler MAX Operations, and FTP Destinations values are applied to all Config Sync Services on the location of the currently selected service. If you modify any of these values, a warning dialog box appears asking if you want to continue. The SNMP Settings User Profile is applied to all Config Sync Services, regardless of their location. If you set SNMP settings as a Config Sync Services user, the settings are used by all Config Sync Services when communicating by means of SNMP.

2. Set the Config Sync Services parameters (Table 8).



**NOTE:** You can edit the RMI Registry Port value of the selected Config Sync Service when the status is Not Run Yet or Not Responding for all Config Sync Services on the location of the selected service. The new setting takes effect when the Config Sync Services on that location are started.

When you set the FTP Destinations parameter to Same for Discovery & Staging, only one set of FTP Destination parameters appears for both discovery and staging. When you set the parameter to Separate Destinations, two different sets of FTP Destinations parameters appear.

When you change the FTP Destinations parameter from Separate Destinations to Same for Discovery & Staging, a dialog box appears prompting you for the settings to use. Click either Discovery or Staging.

**Table 8: Config Sync Services Parameters**

Parameter	Default	Range/Options	Description
SNMP Settings User Profile	admin	User profile name	User profile that the Config Sync Service uses when communicating by means of SNMP.
<b>Config Sync Service</b>			
RMI Registry Port	Set during installation	0–65535	Port with which the Config Sync Service registers. The standard default for the port is 1099; if 1099 is in use, you can change the port number.
Scheduler Max Operations	Set during installation	0–2147483647	Total number of operations that can be active in the Config Sync Service at one time; zero indicates no limit.
FTP Destinations	Set during installation	Separate Destinations, Same for Discovery and Staging	Indicator that determines whether Discovery and Staging uses the same set of values for the FTP destination or whether separate sets of values are used.
<b>FTP Discovery Destination and FTP Staging Destination: FTP Settings</b>			
Login	Set during installation	32-character alphanumeric string	Login name for FTP; if you change the Login, the change does not take effect until the next startup.
Password	Set during installation	1024-character alphanumeric string	Password for FTP; if you change the Password, the change does not take effect until the next startup.
Re-enter Password	Set during installation	1024-character alphanumeric string	Validation of Password.
IP Address	Set during installation	Valid IP address	IP address of the FTP destination.
Sub Directory	Set during installation	255 characters maximum	Subdirectory within the FTP area that is used for Discovery and/or Staging; the subdirectory is case sensitive.
FTP Timeout (sec)	Set during installation	1–2147483 seconds	Amount of time, in seconds, when an FTP request is made and is considered unresponsive.
Local Root Directory	Set during installation	255 characters maximum	Directory on the Config Sync server machine that is the FTP root; when you send an FTP request to the target machine, this is the directory you reach; the local root directory is case sensitive.
			<b>NOTE:</b> The local root directory needs write permission and anonymous access.

**Table 8: Config Sync Services Parameters (continued)**

Parameter	Default	Range/Options	Description
Local Sub Directory	Set during installation	255 characters maximum	Subdirectory in the local root directory that is used for Discovery and/or Staging; the local subdirectory is case sensitive.



**NOTE:** If FTP is configured properly, the following URL brings up an FTP connection when placed in a Web browser address line:

`ftp://your IP address:21`

- When you are done, click Save.

## Getting Status Information

You can view the status for every Config Sync Service that is running from the Status field in the Config Sync Services tab. Each Config Sync Service is assigned a Service ID during installation.

Service ID	Location	Start Time	Status
1	10.10.120.237	2005-03-14 08:59	Available
2	10.10.120.237	2005-03-14 08:59	Available
3	10.10.120.237	2005-03-14 08:59	Not Responding
4	10.10.120.237	2005-03-14 08:59	Available
5	10.10.120.237	2005-03-14 08:59	Available
6			Not Installed
7			Not Installed
8			Not Installed
9			Not Installed
10			Not Installed

Table 9 lists the status indicators and their meanings.

**Table 9: Config Sync Services Status Indicators**

Status	Meaning
Available	Config Sync Service is running and is not performing an operation.
Busy	Config Sync Service is running and is performing an operation.
Not Responding	Config Sync Service was running previously but is not running currently.
Not Run Yet	Config Sync Service is installed but was never running.
Not Installed	Config Sync Service is not installed.

## Locating the Config Sync Services Log

All Config Sync Services maintain a log, which details discovery activities. Consult this log file for more information when you are diagnosing an error condition.

The log file (*CfgSyncSvc < serviceID > /CfgSyncSvc < serviceID > .log*) is located in the *log* directory of the *NMC-RX home* directory of the system on which the Config Sync Service is installed. For example:

`<NMC-RX installation directory>/log/CfgSyncSvc<serviceID>/CfgSyncSvc<serviceID>.log`

## Uninstalling Config Sync Services

You can uninstall individual Config Sync Services. When you uninstall a Config Sync Service, you remove all files associated with that service from your machine, as well as its entry in the NMC-RX database.

Before you uninstall, be sure that the NMC-RX database is running and the Config Sync Service that you want to uninstall is not running.

### Uninstalling in Windows

To uninstall a Config Sync Service in Windows:

1. Choose Start > Settings > Control Panel.
2. Double-click Add or Remove Programs.

The Add or Remove Programs dialog box appears.

3. Select the Config Sync Service that you want to uninstall (for example, Juniper Networks CfgSyncSvc6), and then click Remove.
4. Click Uninstall, then Done.

In the Config Sync Service tab, the status for the Service ID of the Config Sync Service that you uninstalled is Not Installed, and the Config Sync Service and its entry are removed from the NMC-RX database.

### Uninstalling in Solaris

To uninstall an individual Config Sync Service from *< NMC-RX installation directory >* /UninstallerData/CfgSyncSvc *< serviceID >* , run:

```
./CfgSyncSvcUninstaller
```

To remove an entire NMC-RX installation from this workstation, run:

```
./NMC-RX_Uninstaller
```

## Removing Config Sync Services from the NMC-RX Database

When the status of a selected Config Sync Service is either Not Responding or Not Run Yet, the Remove button in the Config Sync Services tab is enabled. When you remove a Config Sync Service, you clear it from the NMC-RX database.



**NOTE:** Perform this action only if you uninstalled the Config Sync Service and the uninstaller had a problem clearing the service from the database. For more information about uninstalling a Config Sync Service, see *Uninstalling Config Sync Services* on page 66.

---

To remove a Config Sync Service:

1. From the Configuration menu in either the Network Workshop or the Device Workshop, choose NMC-RX Application Settings, and then click the Config Sync Services tab.
2. Select the Config Sync Service that you want to remove, then click Remove.

A warning dialog box appears indicating that if you remove the service, you cannot use it until it is reinstalled.

3. Click Yes to remove the Config Sync Service.

The IP address of the workstation on which the Config Sync Service was installed is removed from the Config Sync Services table, but the service ID remains. You cannot use this service ID until you reinstall the Config Sync Service.

## Configuring the Polling Service

The Polling Service is an application that collects status information about managed devices by means of SNMP and redistributes that information to network management clients. This service eliminates the need for every client to poll devices individually for status and reduces the SNMP load placed on managed devices. The status must be updated frequently to maintain an accurate view of the device.



**NOTE:** The Security privilege is required to access the Polling Service tab. For more information, see *Chapter 9, Configuring Security Settings*.

To configure the settings in the Polling Service tab:

1. From the Configuration menu in either the Network Workshop or the Device Workshop, choose NMC-RX Application Settings, and then click the Polling Service tab.

2. Set the parameters (Table 10).

**Table 10: Polling Service Parameters**

Parameter	Default	Description
SNMP Settings User Profile	admin	Specifies which user profile to use for SNMP settings.

**Table 10: Polling Service Parameters**

Parameter	Default	Description
RMI Registry Port	1099	Port with which the Polling Service registers. This port is set during installation.



**NOTE:** If you change the RMI Registry Port value, a warning dialog box appears prompting you to shut down and restart the Polling Service for the change to take effect.

If you set SNMP settings as a Polling Service user, the settings are used by the Polling Service when communicating by means of SNMP.

- When you are done, click Save.

## Configuring Remote Login Settings

From the NMC-RX application, you can log in to routers remotely through Telnet or SSH. The selection of either Telnet or SSH is an NMC-RX application-wide setting and is accessible only to users with security privileges. Although the NMC-RX application automatically defaults to Telnet, SSH is considered a more secure alternative to Telnet for logging in to routers remotely.

Only a user with security privileges can configure remote login settings. Otherwise, this menu item is disabled. For more information on using remote login, see *Configuring Remote Login* in *Chapter 9, Configuring Security Settings*.

To configure the remote login settings:

- From the Configuration menu in either the Network Workshop or the Device Workshop, choose NMC-RX Application Settings, and then click the Remote Login tab.

- Set the parameters as shown in Table 11. For example:

**Table 11: Remote Login Parameters**

Parameters	Description
Login Type	<p>Determines the type of login specified through the NMC-RX application:</p> <ul style="list-style-type: none"> <li>■ TELNET ONLY—Default. When selected, SSH is disabled.</li> <li>■ SSH ONLY—When selected, the SSH command-line parameters are enabled and must be specified.</li> </ul>
<b>SSH Command Line</b>	Specifies the parameters in this section for SSH authentication.
Available NMC-RX Arguments	<ul style="list-style-type: none"> <li>■ &lt; HOST &gt; —Specifies the IP address of the device to which you are connecting. When clicked, the &lt; HOST &gt; token is added to the command-line string (see below).</li> <li>■ &lt; USER NAME &gt; —Specifies the username, which is the SSH username set in the NMC-RX user profile. You can use either the NMC-RX username or another username specified by the administrator. When clicked, the &lt; USER NAME &gt; token is added to the command-line string (see below).</li> </ul>
Command Line String	<p>Specifies what is executed when the remote login action starts. The string contains arguments that are necessary for SSH authentication. Syntax example:</p> <pre>ssh2 &lt;USER NAME&gt;@&lt;HOST&gt;</pre> <ul style="list-style-type: none"> <li>■ ssh2—SSH executable</li> <li>■ &lt; USER NAME &gt; —Parameter syntax for username</li> <li>■ &lt; HOST &gt; —Parameter syntax for IP address</li> </ul>
Test	When clicked, the remote login action is started with the command-line string that you specified.

3. Click Save.

## Configuring User Authentication Settings

Only users with security privileges can configure user authentication settings. You can set either RADIUS authentication or local database authentication as the default mode of user login authentication.

For RADIUS authentication, you specify a list of RADIUS servers to authenticate user logins and set the order in which they are queried. You configure RADIUS authentication on a per user basis when you create user profiles (see *Setting SSH Username Source* on page 138 for more information).

To configure user authentication settings:

1. From the Configuration menu in either the Network Workshop or the Device Workshop, choose NMC-RX Application Settings, and then click the NMC-RX User Authentication tab.

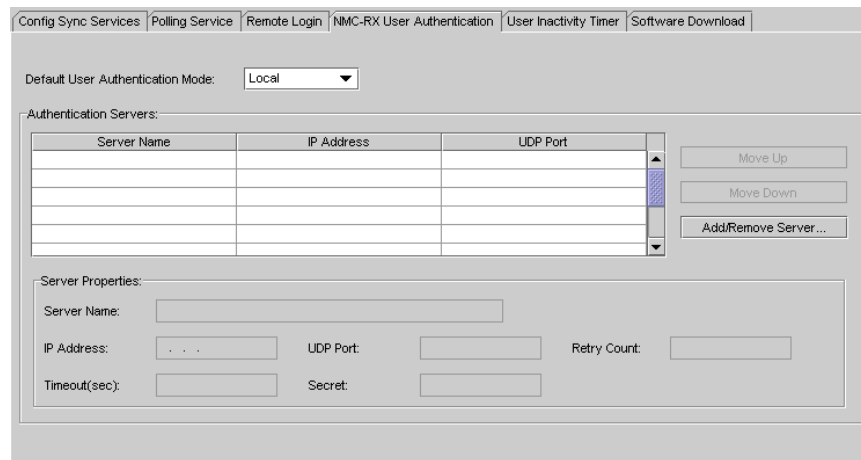

2. Set the user authentication parameters (Table 12).

**Table 12: User Authentication Parameters**

Parameter	Description
Default User Authentication Mode	Method by which user logins are authenticated: either locally or with a RADIUS server by default.
RADIUS Authentication Servers	<p>List of RADIUS authentication servers that are available to authenticate NMC-RX user logins.</p> <p>List is sorted in the order that the servers are used when a user authentication takes place. When a server fails to respond with an acceptance, rejection, or challenge, the next server in the list is tried.</p> <p>To add or remove a server from the list, click the Add/Remove Server button (see <i>Related Dialog Box</i> on page 71).</p> <p>Select a server from the list, and click the Move Up and Move Down buttons to change the order in which the servers are checked.</p>
<b>Server Properties</b>	
Server Name	Name of the selected RADIUS server; cannot edit
IP Address	IP address of the selected RADIUS server; cannot edit
UDP Port	UDP port of the selected RADIUS server; cannot edit
Retry Count	Number of times to retry the selected RADIUS server; range 0-16; default 3

**Table 12: User Authentication Parameters (continued)**

Parameter	Description
Timeout (sec)	Time to wait to receive a response from the selected RADIUS server; range 3-30; default 3
Secret	String that is known by the server and the client used to obfuscate the packets that are exchanged between the server and client; range 0-32 characters; default is empty

3. Click the Save button.

The default user authentication settings are saved.

## Related Dialog Box

### Add/Remove RADIUS Authentication Servers

The Add/Remove RADIUS Authentication Servers dialog box appears when you click the Add/Remove Server button on the User Authentication Settings tab.

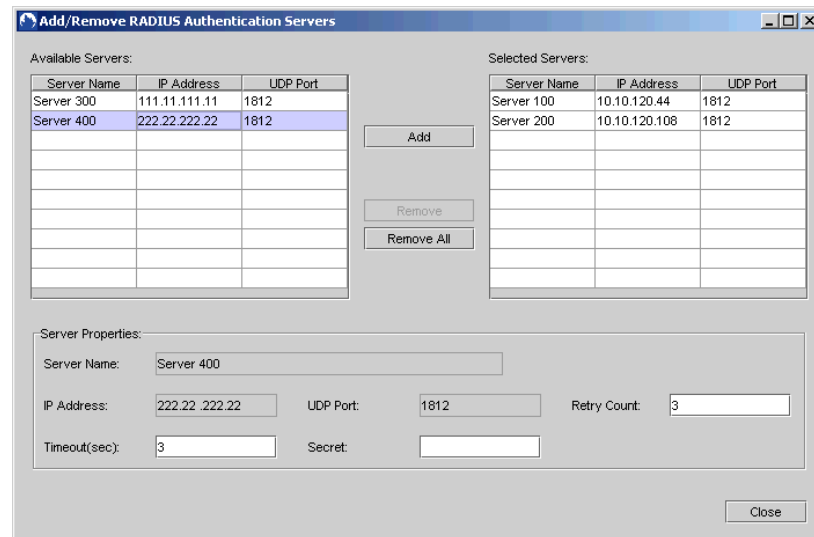

The Available Servers list (left) lists all authentication servers that you created or discovered that are not selected. You can select up to ten servers in the Selected Servers list (right) to authenticate user logins.

To add or remove servers:

1. Select a server from a list, and click either Add or Remove.

The server is added to or removed from the appropriate list.



**NOTE:** When you add a server, you can change the parameters for the selected server in the Server Properties group box (see Table 12 on page 70 for field descriptions).

2. Click Close.

The server(s) are added to or removed from the RADIUS Authentication Servers list on the NMC-RX User Authentication Settings tab.

## Configuring the User Inactivity Timer

You can use the user inactivity timer to specify the period of time that the NMC-RX application waits before it closes due to user inactivity. If you do not perform any tasks (view, configure, update, etc.) in the time specified, a message dialog box appears indicating that your session has ended.

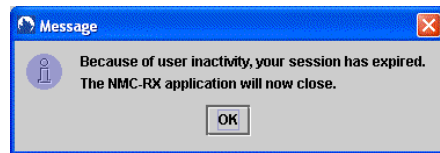

When you click OK, all open dialog boxes and workshops close and the NMC-RX application exits. You must restart the application and log in again to continue using it. The timer is reset each time you click the mouse or press a keyboard key within the NMC-RX application. When the application is busy, the timer is disabled but restarts when the task is completed.



**NOTE:** Only users with a security privilege can configure the user inactivity timer. For more information, see *Chapter 9, Configuring Security Settings*.

To enable or disable the user inactivity timer:

1. From the Configuration menu in either the Network Workshop or the Device Workshop, choose NMC-RX Application Settings, and then click the User Inactivity Timer tab.

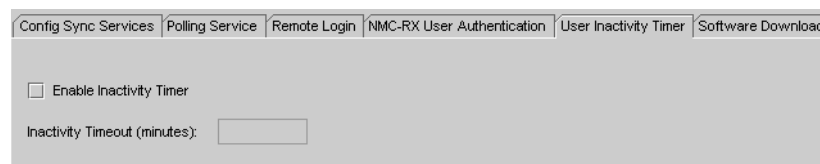

2. Set parameters (Table 13).
  - To enable the timer, select the Enable Inactivity Timer check box, and enter a value in the field.
  - To disable the timer, clear the Enable Inactivity Timer check box.

**Table 13: User Inactivity Timer Parameters**

Parameter	Description
Enable Inactivity Timer	Enables or disables the timer
Inactivity timeout (min)	Number of minutes to wait before exiting the application during a period of inactivity; range 5-1000 minutes; default is set during installation

3. Click Save.

All current sessions are updated when the timer starts again.

## Configuring Software Download Settings

You can remotely download JUNOS software releases from a centralized location to one or more E-series routers. For example, you can select a specific software release and then download the file to multiple E-series routers at the same time.

The Software Download tab lets you enable the download software feature and configure the Software Repository FTP Settings, which you use to download the software. If you do not enable the FTP server, you cannot download the software to E-series routers using the NMC-RX application.

For more information on downloading software, see *Downloading Software Releases to Devices* in *Chapter 6, Configuring the System*.



**NOTE:** Only users with a device maintenance privilege can configure software download settings. For more information, see *Chapter 9, Configuring Security Settings*.

To configure the software download settings:

1. From the Configuration menu in either the Network Workshop or the Device Workshop, choose NMC-RX Application Settings, and then click the Software Download tab.

2. Set the Software Download parameters (Table 14).

**Table 14: Software Download Parameters**

<b>Parameter</b>	<b>Description</b>
Enable Software Downloads	Select to enable software downloads; clear to disable the feature.
<b>Software Repository FTP Settings</b>	
IP Address	IP address of the Software Release Repository where the software is stored.
Login	User login ID for the FTP site; can be up to 32 characters; default: anonymous.
Password	User login password for the FTP site. The password entry is masked with "*" characters. You cannot leave the password blank; the password can be up to 1024 characters.
Sub Directory	Path from FTP root to the NMC-RX software releases directory; optional; range 255 characters.
Concurrent Downloads	Maximum number of simultaneous downloads that the FTP server allows; range: 1-10; default: 5.

3. Click Save.