

## Chapter 6

# Organizing Your Network with Groups and Devices

This chapter describes how to organize your network using groups and devices.

This chapter contains the following sections:

- Overview on page 90
- Group Configuration Tasks on page 90
- Creating a Group on page 91
- Configuring a Group on page 93
- Viewing a Group on page 94
- Deleting a Group on page 96
- Viewing the Lost & Found Folder on page 96
- Device Configuration Tasks on page 96
- Creating a Device on page 97
- Configuring a Device on page 99
- Viewing a Device on page 100
- Deleting a Device on page 101
- Adding Members to a Group on page 102

## Overview

---

Within the NMC-RX Network Workshop, you can create *groups* to structure your network hierarchy logically. Depending on the size and complexity of your network, you can structure as many group levels as you need.

Within these groups, you can associate other groups or *devices*, creating a hierarchy of relationships. By organizing your network into groups and associating devices with the groups, you can easily locate the groups and devices.

Only users with security privileges can create, configure, and delete groups. Only users with device administration privileges can create, update, and delete devices from the database.

## Group Configuration Tasks

---

You can perform the following configuration tasks for groups:

- Create a group
- Configure a group
- View a group
- Delete a group
- View the Lost & Found folder

For each of these procedures, you can either select from the NMC-RX Configuration menu or right-click an object and select from the pop-up menu.

## Creating a Group

As you manage your network with the NMC-RX application, you create groups to organize your customer accounts and devices.

The NMC-RX application provides the flexibility to organize groups. You can configure an unlimited number of group levels. Each group can contain any number of groups or devices.

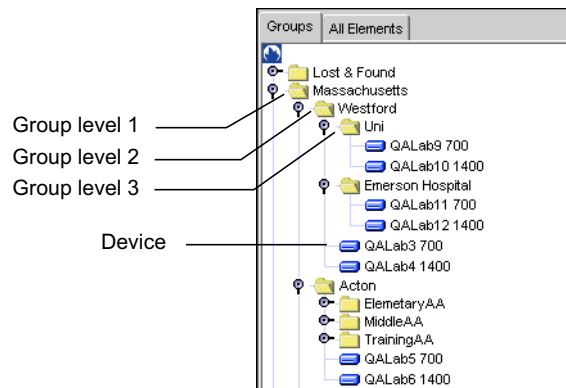

To create a group:

1. From the Network Workshop, select any group to which you want to add another group, right-click, select Create, then click Group.

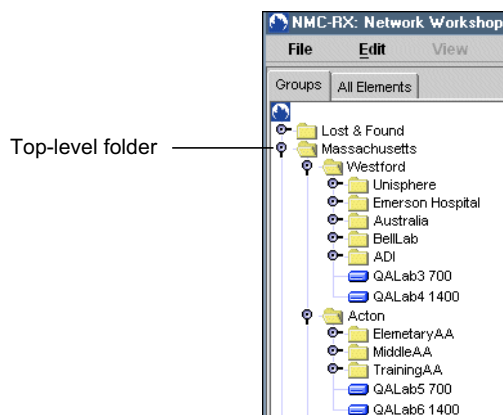

The Create Group dialog box appears.

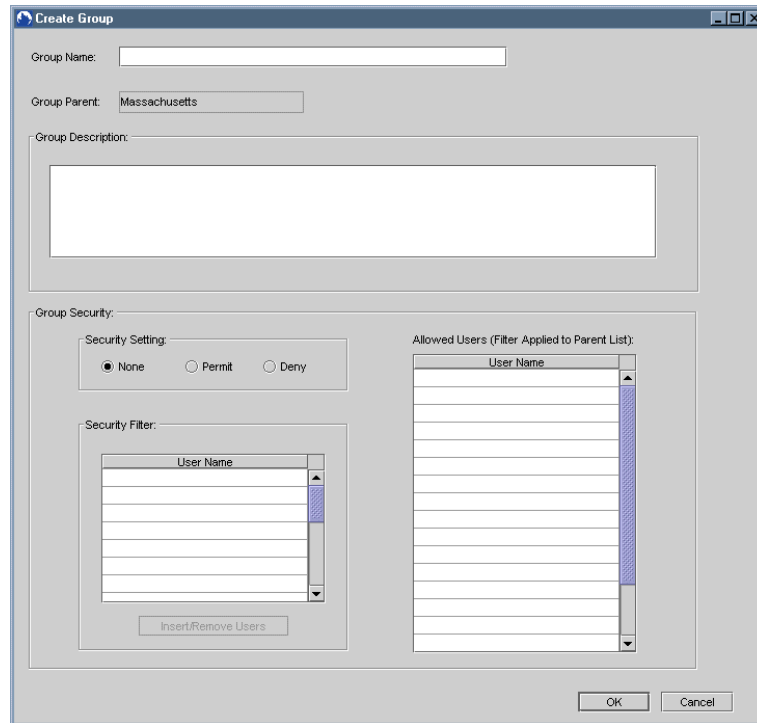

2. Set the group parameters (Table 20).

**Table 20: Group Parameters**

Parameter	Description
Group Name	Name of the group; may not exceed 32 alphanumeric characters and may include spaces.
Group Parent	Group to which this group belongs.
Group Description	Descriptive or contextual information about the group up to 256 alphanumeric characters. The description appears whenever you access its associating group. You can change or delete a description at any time.
<b>Group Security</b>	
Security Setting	<ul style="list-style-type: none"> <li>■ None—No filter is applied.</li> <li>■ Permit—List of users who can access the group.</li> <li>■ Deny—List of users who cannot access the group.</li> </ul>
Security Filter	<ul style="list-style-type: none"> <li>■ User Name—Name(s) of the user(s) to whom you give security access in the group you are configuring.</li> <li>■ Insert/Remove Users—Click to access the dialog box that lets you add or delete user accounts from the filter list you are configuring.</li> </ul>
Allowed Users	User Name—Filtered list of all defined usernames



**NOTE:** For detailed information about security features, see *Chapter 8, Configuring Security Settings*.

3. Click OK.

The new group name and folder icon appear in the list in the Network Workshop context area.

## Configuring a Group

When you configure a group, a user with security privileges is the only one who can:

- Rename the group and record important information in the Description text box.
- Change the security specifications for the group. (See *Chapter 8, Configuring Security Settings*.)

To configure a group:

1. From the Network Workshop, select the group that you want to configure, right-click, and select Configure.

The Group Configuration tab appears.

The screenshot shows a dialog box titled 'Save' with two tabs: 'Group Configuration' and 'Group Security'. The 'Group Configuration' tab is selected. It contains the following fields:

- Group Name: Acton
- Description: Town in MA
- Parent Name: Massachusetts

Below these fields is a section labeled 'Contained By:' which contains a table with the following data:

Name	Type
Massachusetts	Group

To the right of the table is a 'View Group >>' button and a large empty rectangular area.

2. Type the name of the group and a description in the text boxes.

The description may be especially helpful in an environment where multiple network administrators need access to special customer information. The information is displayed whenever you access its associated group. You can change or delete the description at any time.



**NOTE:** To perform group security functions, click the Group Security tab at the top of the Group Configuration work area. For information about group security, see *Chapter 8, Configuring Security Settings*.

## Viewing a Group

You can view the hierarchy of a group itself or of the group to which it belongs.

To view the hierarchy of a group:

1. In the context area of the Network Workshop, select the group that you want to view, right click, and select View.

The Group Configuration tab appears.

2. In the Contained By group box, click the group whose hierarchy you want to view.

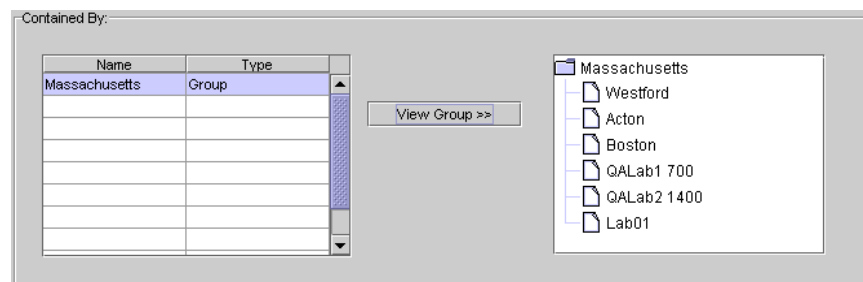

3. Click the View Group button.

The group hierarchy appears in the Contained By group box in the pane on the right. If the group belongs to more than one group, you can view the place of the group in each group to which it belongs.

You can continue to select groups and view their hierarchies by expanding folders. If you click a group icon and it is not at the lowest level, it becomes a folder. When the group icon does not expand, you are at the lowest level in the group hierarchy. See the following example.

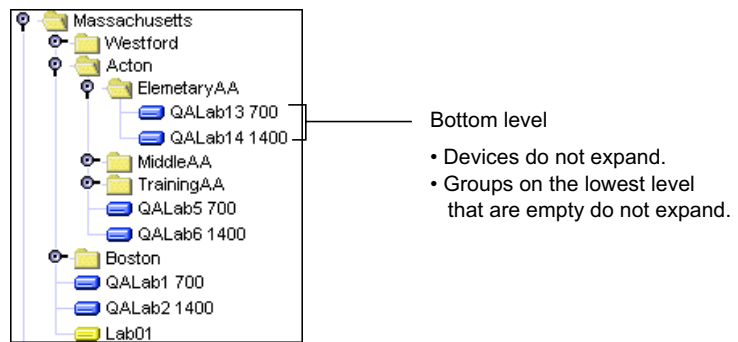
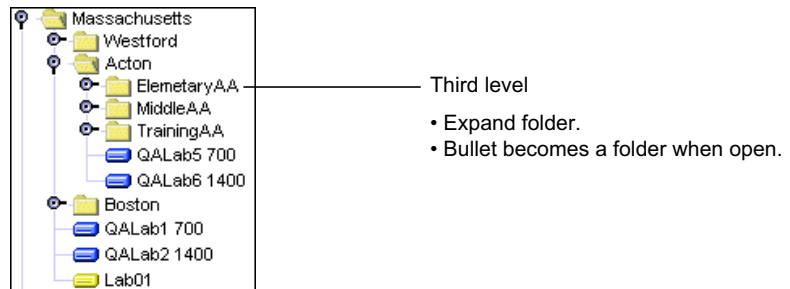
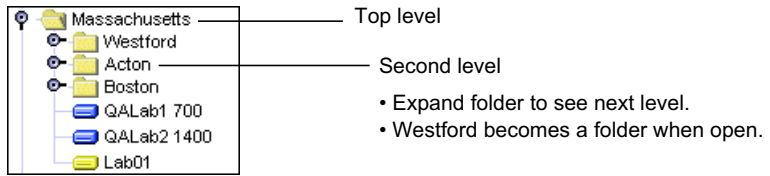

## Deleting a Group

---

If you have security privileges, you can delete a group that is no longer needed. We suggest that you delete groups from the bottom up. That is, delete a child group before deleting the group to which it belongs.

A group can be a member of more than one group. If you do not have security access to all the groups to which it belongs, you cannot delete the group. You are allowed to remove the group from the group to which you have security access. Although you remove the group from the group to which it belongs, the group is not deleted from the system. See *Chapter 8, Configuring Security Settings*.

To delete a group:

1. Click the group icon that you want to delete, right-click, and select Delete.

The Confirm Delete dialog box appears.

2. Click OK.

The group is deleted immediately.

The NMC-RX application lets you delete a group that contains groups and/or devices. Although the groups or devices are deleted from the group to which they belong, they are not removed from the database, and you can insert them into different groups at a later time.

## Viewing the Lost & Found Folder

---

Objects, such as devices, may be orphaned if they are removed from a group and no longer have an association with a group. Orphans can also occur when there is a failure to discover or update a particular device.

The Lost & Found folder immediately reflects any groups or devices that are orphaned during your session. To see orphans created by other NMC-RX users, right-click on the Lost & Found folder, and click Update.

## Device Configuration Tasks

---

While managing your network with the NMC-RX application, you can create and configure devices to be part of your network hierarchy. You can perform the following configuration tasks for devices:

- Create a device
- Configure a device
- View a device
- Delete a device
- Add a device to the network

## Creating a Device

You create a device so that the NMC-RX application can discover the physical device by its IP address. Once the *physical* device is located on the network, the application builds a *logical* representation of the device, which you can view through the Instance Explorer.

All modules physically installed in the slots of the device are identified by the application and are represented logically in the Instance Explorer. For example, if the application discovers a network device with a CT3 module in slot 5, the Instance Explorer shows slot 5 with three line interfaces (T3s), each having 28 DS1 interfaces (T1s).

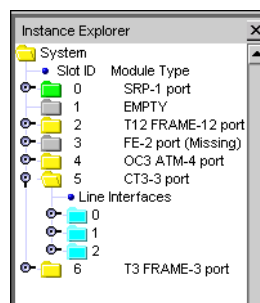

To create a device:

1. From the Network Workshop, select the group name to which you want the new device to belong.

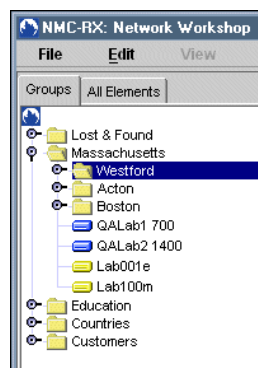

2. Right-click, select Create, and click Juniper RX Device.

The Create System dialog box appears.

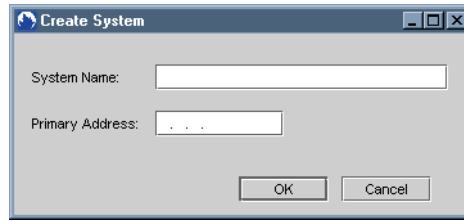

3. Set system parameters (Table 21).

**Table 21: Create System Parameters**

Parameter	Description
System Name	Name that you assign to the device. Name must not exceed 32 characters and can include spaces.
Primary Address	IP address that you use to communicate with the device.

4. Click OK.

The Creating Device window appears and automapping of the device begins.

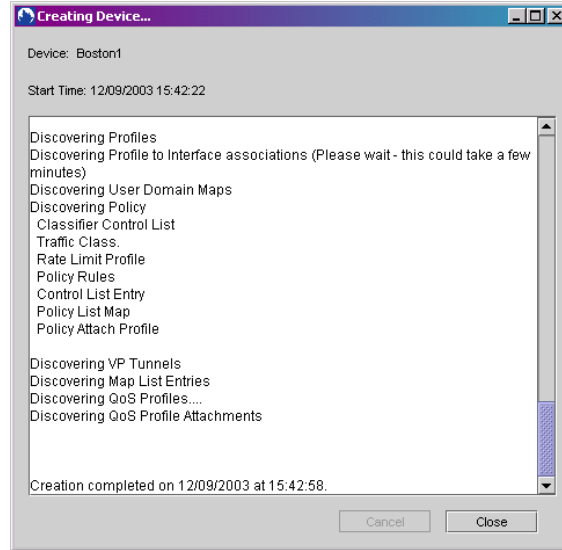

Depending on the device configuration, this process may take a few moments. When automapping is complete, the NMC-RX application adds the device to the selected group in the Network Workshop.



**NOTE:** When NMC-RX begins to automap the device, if you close the Creating Device window or click the Cancel button, a confirmation dialog box appears.

Any error messages or warnings that may occur during the update appear in the Updating Device dialog box. When the update is complete, a pop-up dialog box appears if there are any errors or warnings.

5. If you want to update the device regardless of the error or warning, click Yes.
6. Close the Creating Device window.

The NMC-RX application acknowledges the creation of the device.

7. Click OK.

The new device appears in the list in the Network Workshop context area.

## Configuring a Device

This section describes how to configure devices. For more detailed information about configuring devices, see the various configuration chapters in this user guide and in *Chapter 5, Configuring the System*.

To configure an existing device:

1. Select the device, right-click, and select Configure.

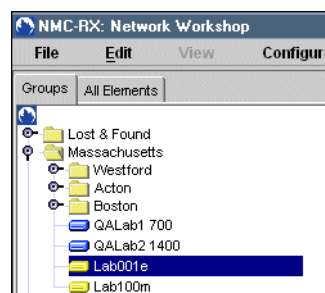

The device appears in the Device Workshop Instance Explorer with all modules installed on it.

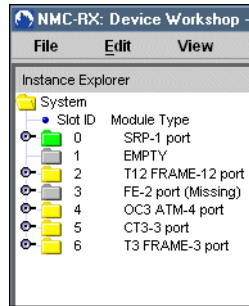

- To continue the system configuration, see *Chapter 5, Configuring the System*. To configure the modules for a device, see the appropriate configuration chapters in this guide.

## Viewing a Device

---

To view the configuration of a device, you can use either the Network Workshop or the Device Workshop.

- From the Network Workshop, select the device in the context area, right-click, and select View.
- From the Device Workshop and from either the Instance Explorer or the Device-wide Explorer, select System, right-click, and select View.

The System Info tab appears. You cannot modify any settings in this tab or any other tabs that are displayed for viewing.

## Deleting a Device

If you have device administration privileges, you can delete a device. We do not recommend, however, that you delete a configured device. If you need to delete a device, the NMC-RX application allows you to delete it from the Network Workshop. If you delete a device, you must re-create the device to get the model again.



**NOTE:** A device can be a member of more than one group. If you do not have security access to all the groups of which the device is a member, you are not allowed to delete the device. You are allowed to remove the device from the group to which you have security access. See *Chapter 8, Configuring Security Settings*.

Occasionally, you may need to delete a device that you created in error.

To delete a device:

1. From the Network Workshop, select the device that you want to delete, right-click, and select Delete.

The Confirm Delete dialog box appears.

2. Click OK.

The device is deleted.

## Adding Members to a Group

You can add and remove multiple groups or devices to and from a group.

### Adding a Group to an Existing Group

To add a group to an existing group:

1. In the Network Workshop context area, select a group, right-click, and select Insert/Remove Members.

The Insert/Remove Group Members dialog box appears.

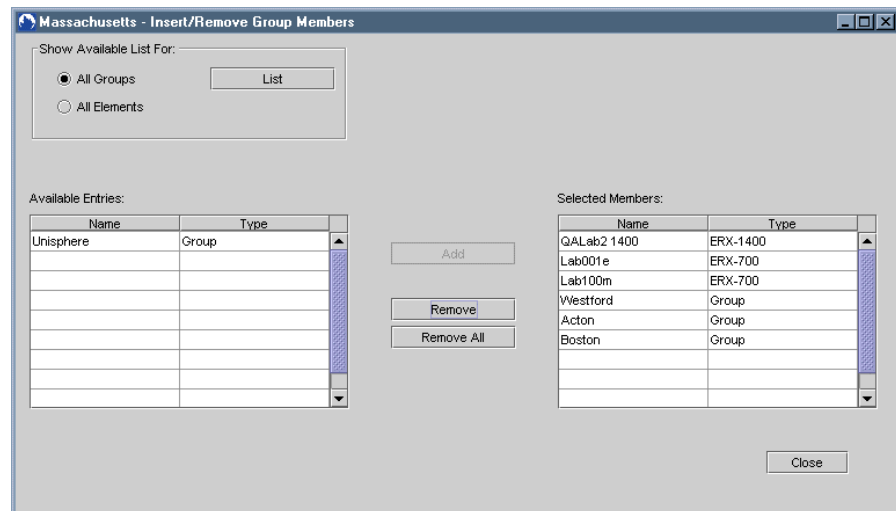

2. Select All Groups, and click List.

A list of groups appears in the Available Entries list.

3. Select a group in the Available Entries list, and click Add.

The group members appear in the Selected Members list and are added to the selected group.

### Removing a Group

To remove a group, select a group in the Selected Members list, and click Remove.

The group is removed from the Selected Members list and appears in the Available Entries list.

### ***Adding a Device***

To add a device:

1. Select the All Elements option button, and click List.

A list of all available devices appears in the Available Entries list.

2. Select a device, and click Add.

The device appears in the Selected Members list and is added to the group.

### ***Removing a Device***

To remove a device, select the device in the Selected Members list, and click Remove. The device is removed from the Selected Members list and appears in the Available Entries list.

