

Release 6.1.1

These *Release Notes* are for NMC-RX Element Management System Release 6.1.1. Unless specified otherwise, information in these *Release Notes* pertains to both the Windows and Sun Solaris versions of the Release 6.1.1 software.



NOTE: If the information in these *Release Notes* differs from the information found in the product documentation, follow these *Release Notes*.

These *Release Notes* include the following sections:

- Overview on page 1
- New Features and Enhancements on page 2
- Provisioning Server Enhancements on page 4
- Installation Information on page 5
- Known Problems on page 6
- Known Limitations on page 6
- Troubleshooting on page 7
- Fixed Problems on page 8

Overview

The NMC-RX application allows you to manage, configure, and monitor the E-series routers in your network and to communicate with them to obtain a complete and accurate picture of the network services that you provide to your customers.

Before You Start

Before you use the NMC-RX application, we suggest that you read these *Release Notes* in their entirety, especially the sections *Known Problems* and *Known Limitations*.

About Release 6.1.1 Documentation

With the NMC-RX application, you receive the following documentation:

- Online Help (integral to the NMC-RX application)
- A PDF version of the *NMC-RX User Guide* (Vol. 1 and Vol. 2)
- A PDF version of the *NMC-RX Release Notes* (this document)

Contacting Customer Service

For technical support, contact Juniper Networks at <http://www.juniper.net/support/>, or at 1-888-314-JTAC (within the United States, Canada, or Mexico) or 408-745-9500 (from elsewhere).

Updating the NMC-RX License Keys

If you need to update your license keys after you install the NMC-RX application, choose NMC-RX Licensing from the Help menu. In the NMC-RX Licensing Information dialog box, you can change either your NMC-RX, Config Sync Services, or Provisioning Service license key.

New Features and Enhancements

NMC-RX Release 6.1.1 includes new features and enhancements (defined in the following sections). These features have been added to the NMC-RX application since Release 6.0.0 and Release 6.1.0.

This release is intended to work with JUNOS Releases 6.0.x and 6.1.0. This release is also compatible with JUNOS Releases 5.2.x and 5.3.x.

Canceling a Recurring Scheduled Task That Is in Progress

You can now cancel a recurring scheduled task that is currently in progress. Do this by deactivating the scheduled task in the List All area or when viewing the scheduled tasks for a particular device.

Discovery Performance Improvements

NMC-RX Release 6.1.1 uses a distributed processing model to provide greater scalability and control of discovery and update processes for E-series devices (Figure 1). Discovery performance improvements have been made for the following objects:

- ATM SubInterfaces
- ATM Circuits
- IP Interfaces
- IP Addresses
- Policy Lists
- Classifier Control Lists
- Traffic Classes
- Rate Limit Profiles
- Policy List Rules
- Policy/Interface
- Policy/Profile

Figure 1: Sample Config Sync Services Distribution

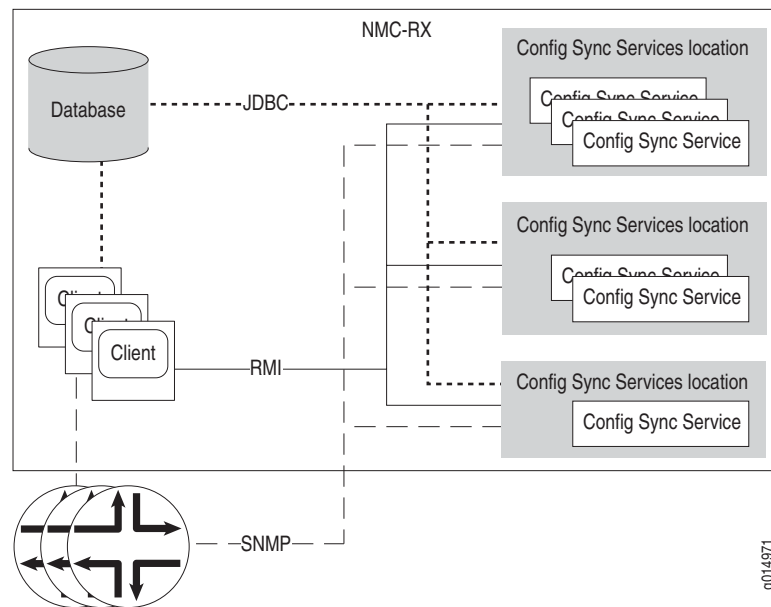

A Config Sync Services pool allows multiple Config Sync Services to be active simultaneously, thus providing a wealth of processing power that is available to multiple Config Sync Services locations. With the addition of the new Config Sync Services installation option, a system administrator can choose to install one or more Config Sync Services on a workstation without having to install the other NMC-RX components.

You can run multiple Config Sync Services on a single platform or utilize multiple platforms as part of the same NMC-RX Config Sync Services pool. You can oversee and manage the distributed Config Sync Services pool using the NMC-RX client application. For more information about Config Sync Services, see *NMC-RX User Guide, Vol. 2, Chapter 11, Configuring Config Sync Services*.

Provisioning Server Enhancements

The following changes have been made for the Provisioning Service.

ATM Subinterface Provisioning Object

The ATMSUBINTF_DISTINGUISHER attribute has been added to the ATMSubInterface object type in the unspRXDeviceMgr.idl file. It was also added to the NMC-RX application.

Attribute	Characteristic	Description	MIB Entry
ATMSUBINTF_DISTINGUISHER	Create	ATM identifier used to uniquely characterize the subinterface on this ATM interface.	juniAtmSubIfDistinguisher

ATM PVC Provisioning Object

The characteristic in the ATM PVC object type in the unspRXDeviceMgr.idl file has been changed from View to Create.

Attribute	Characteristic	Description	MIB Entry
VCD	Create	Virtual circuit descriptor	juniAtmSubIfVccVcd

PVS Test Utility Dialog Box

Two new fields, EMS Name and Port, have been added to the PVS Test Utility dialog box. You can now name and run multiple uniquely named PVS Services to one NMC-RX database.

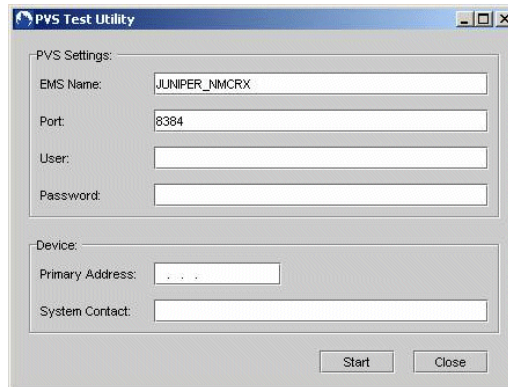

Running Multiple PVS Services to One NMC-RX Database

To run multiple uniquely named PVS Services to one NMC-RX database, follow these steps. Note that there must be one dedicated Provisioning Service for each CORBA client:

1. Start the Naming Service.
2. Modify the PVS.rc file by assigning a unique emsName and server port for the Provisioning Service.
3. Start the NMC RMI Service.
4. Start the NMC CORBA Service.
5. Start the PVS Test Utility, and confirm that the emsName (Provisioning Service) is up and functioning as expected.
6. Modify the PVS.rc file again by assigning a different emsName and server port for the Provisioning Service.
7. Repeat step 3–5.

Installation Information

See *NMC-RX User Guide, Vol. 1, Chapter 2, Installing and Running the NMC-RX Application*.

Solaris software patches 108940-50 and 108652-66 are required to install the NMC-RX application on Solaris 2.8. To find the required patches for your system, visit:

<http://sunsolve.sun.com/pub-cgi/show.pl?target = patches/patch-access>

Upgrading to Release 6.1.1

You can upgrade to Release 6.1.1 only from Release 6.1.0. You cannot upgrade to Release 6.1.1 from releases earlier than Release 6.1.0. If you do have a release before Release 6.1.0, you must first upgrade to Release 6.1.0 and then upgrade to Release 6.1.1.

Once you upgrade Release 6.1.0 to Release 6.1.1, you will not be able to revert back to 6.1.0. We recommend making a copy of the installation directory and storing it outside of the NMC-RX installation area so that you are able to revert to the previous installation if needed.

Known Problems

This section lists the known problems in Release 6.1.1:

- When you use Add/Remove Programs in Windows to remove the Juniper Networks NMC-RX application, all Config Sync Services are also removed. However, entries for the Config Sync Services still appear in the Add/Remove Programs dialog box.

Workaround: Close, then reopen the Add/Remove Programs dialog box to refresh it and confirm that the Config Sync Services entries no longer appear.

- When statistics are running, if an SNMP error is received on another operation (create, for instance) and you do not click the OK button on the error message dialog box within a certain number of seconds, an SNMP timeout error is returned for the SNMP statistics get request. The same result occurs if the SNMP error is on one device and the statistics polling is occurring on another.

After you click OK on the error dialog box, everything returns to normal with the next poll.

- When configuring an interface, if you display the Module Config tab (by clicking the Lower Layer button) and then close it (by clicking the X button), all other tabs are closed and the original interface remains locked.

Workaround: Users with Security privileges enabled can right-click the System folder and choose Unlock Device.

- An SNMP error occurs when you try to configure an IP static route and select a nonbroadcast multiaccess (NBMA) or broadcast IP interface as the next hop. Only IP interfaces with a category of point-to-point can be used as the next hop for an IP static route.
- IP interfaces that you choose for any forward or next interface rule within a policy list must exist on the same virtual router. An SNMP error occurs if you add a forward or next interface rule to the policy list that specifies an IP interface from a different virtual router.

Known Limitations

This section lists the known limitations in Release 6.1.1:

- When you click Install on the Pre-Install Summary dialog box during installation, there is a short amount of time when the database updates. If you click Cancel during this time, the database remains locked for the installation of additional Config Sync Services.

Recommendation: Do not click Cancel after the installation begins. Instead, allow the installation to complete, and then use the NMC-RX Uninstaller or Config Sync Services uninstaller to remove the desired components.

- When you use Bulk Services to create a large number of objects, limit the number of objects to a maximum of 9000. Otherwise, you run the risk of running out of memory. To create additional objects, you can exit the NMC-RX application and then restart.
- Currently, the NMC-RX application allows you to start multiple Polling Services at the same time. Only one Polling Service is actually used by the application. There will be no disruption of service if you start additional services; however, it is a waste of resources to do so, and currently no error message is displayed to indicate any displacement of the service being used. All instances of polling should be closed, and only one restarted.
- When the Config Sync Services and the Polling Service are started before the database has completely initialized, an error occurs.

Recommendation: Wait until the database is initialized before launching other NMC-RX components. If an error has occurred, close all NMC-RX components (including the database) and start over.

- If you edit the Integrated Local Management Interface (ILMI) settings (virtual path identifier [VPI] and virtual circuit identifier [VCI]) of an ATM interface while the ILMI Settings Admin Status is set to “Up,” an SNMP error occurs.

Workaround: Before changing VPI and VCI settings, change the ILMI Settings Admin Status to “Down,” and click Save. Next, update the VPI and VCI settings, and click Save. Then, change the ILMI Settings Admin Status back to “Up,” and click Save.

- An error may occur if, during a device update, you attempt to make changes to a scheduled task and save them.

Workaround: Wait until the device has been updated, and then edit the scheduled tasks.

- You cannot create Frame Relay major interfaces for devices running JUNOS release 6.1.0. You can create Frame Relay major interfaces for devices running JUNOS release 6.0.0 or earlier.

Troubleshooting

If any of the following conditions appear, try the suggested workarounds.

- The default port for Java RMI (Remote Method Invocation) is 1099. If this port is in use, Polling Service and Config Sync Services do not run correctly, and an error message appears.

Workaround: Go to NMC-RX Application Settings in the Configuration menu. On the Config Sync Services tab, select the desired service, and change the RMI Registry Port from 1099 to another number (for example, try 1300). Now, click the Polling Service tab, and change the RMI Registry Port from 1099.

- Two causes prevent WebHelp from starting on Solaris:
 - You have not defined the Netscape path in the PATH variable. This results in an error message being displayed in the NMC-RX window.

Workaround: Define the Netscape path.
 - You may not have permission to connect to the X server. This prevents Netscape from being started. When this happens, no error message is generated, and you may think that the online help does not work properly.

Workaround: Enter the command `xhost < hostname >` in a term window. Doing this disables the X server security and allows the Netscape browser to be displayed.
- If your desktop shortcuts do not display the correct icon, use the following workaround.

Workaround

 - a. Right-click your desktop, and choose Properties.
 - b. In the Display Properties control panel, select the Appearance tab.
 - c. Under the Item option, select Icon and change the icon's size from 32 to 31.
 - d. Click Apply, and click OK.
 - e. Repeat Steps a–d, and return the icon's size to 32 (Step c).

Fixed Problems

The following problems reported in previous releases have been fixed:

- Sybase 9.0.2 is now part of the NMC-RX application installation. This enhancement enables support of Solaris 2.9. When installing the NMC-RX application, choose the Sybase option or be sure that Sybase 9.0.2 is already installed.
- The PVS log file now provides:
 - Input information coming from the CORBA client. It includes all requested parameter values and actions (for example add, delete, and modify).
 - Input and output information sent to the CORBA client for each CORBA client, including success and failure status. The information includes CORBA exception messages as the CORBA client would see them.

- Logs for requests sent to the router corresponding to each CORBA client request. It also includes the router responses to the EMS request, if a request failed, and the reasons for the failure.
- A timestamp for the time each input and output that was received and sent by the EMS.
- PVS-related log files in the EMS have been consolidated. There are two fixed log files per PVS Service/emsName: nmcPvsRMIServer and nmcPvsCORBAServer. Each of these log files now includes the emsName and timestamp in the log file name to improve usage of the logs.

Also, there is one log generated per client connection; it is labeled with the user name and timestamp.

- The OAM Loopback Enable and OAM Loopback Frequency parameters are read-only when you create and configure ATM interfaces using the NMC-RX client and NMC-RX Provisioning Service for devices that are running JUNOS Release 6.1.0. You can configure these parameters for devices running JUNOS Release 6.0.0 or earlier.
- During installation of the NMC-RX application on Solaris, if you choose Yes for the question “Do you want to use the same FTP destination for Staging,” the FTP password setting is not saved correctly, and the Discovery and Staging settings will not match in the NMC-RX Application Settings dialog box (accessed through the Configuration menu).
- After installation, if an invalid FTP discovery or staging setting is specified for a Config Sync Service on the NMC-RX Applications Setting dialog box (accessed through the Configuration menu), that Config Sync Service’s parameters are deleted from the database.
- Enhancements have been made to the Provisioning Service to improve memory usage.
- The keepalive pings in the Provisioning Service have been disabled.

