

Chapter 3

Routing Matrix

The routing matrix is the next-generation routing system from Juniper Networks. By combining multiple T640 Internet routing nodes with a centralized switch fabric called the TX Matrix platform, a routing matrix turns these devices into one very large routing platform. This guide identifies the configuration and operational commands required to configure a routing matrix and compares them to the commands you issue on a standalone T640 routing node. This information is designed to help you understand how the JUNOS command-line interface (CLI) has been enhanced to accommodate configuration, management, and operation of a routing matrix.

This feature guide covers these topics:

- Overview on page 124
- System Requirements on page 125
- Terms and Acronyms on page 125
- Configuring a Routing Matrix on page 126
 - Example: Routing Matrix Configuration on page 131
 - Checking Your Work on page 138
- Routing Matrix Hardware and Software Considerations on page 155
- For More Information on page 167
- Revision History on page 167

Overview

The routing matrix is the first multichassis product from Juniper Networks. The T640 and T320 routing platforms were the first core routers that provided scalable bandwidth and intelligent networking features with a capacity of 80 to 640 gigabits per second (Gbps) of throughput. A key part of the T-series design was the ability to scale individual T640 routing nodes to 2.5 terabits of bandwidth by combining them in a multichassis configuration. Such scalability is now available with the routing matrix.

The physical system of a routing matrix consists of one TX Matrix platform and from one to four T640 routing nodes, as shown in Figure 14. A key element of the routing matrix design is the ability to migrate existing T640 routing nodes and connect them with the TX Matrix platform through fiber-optic cables and Switch Interface Boards (SIBs).

Figure 14: Routing Matrix Architecture

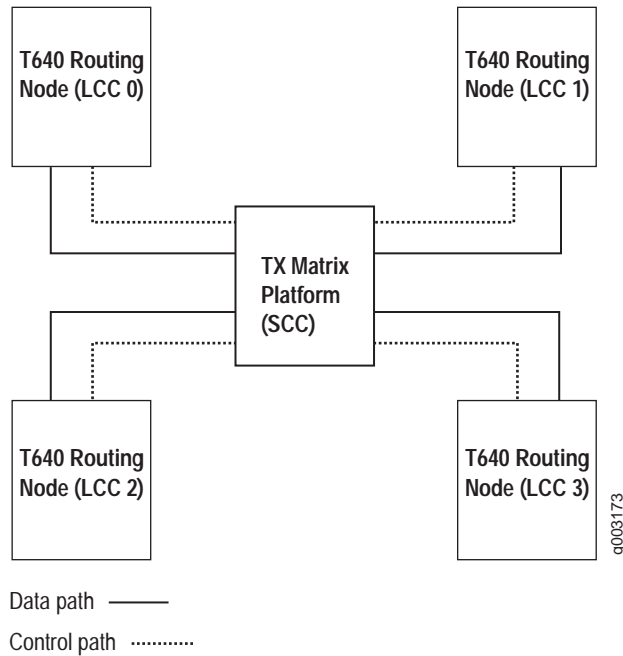

The TX Matrix platform connection between the T640 routing nodes uses a scalable, three-stage switch fabric. This system architecture provides terabit bandwidth expansion capacity and eliminates the use of subscriber line cards to connect devices within points of presence (POPs). As a result, the primary application for the routing matrix is to collapse aggregation and core layers in large POPs and central offices.

The routing matrix appears as a single router to the operator and utilizes the existing JUNOS CLI for configuration and management. To manage this multichassis system, some enhancements have been made to the CLI that allow you to select the amount of output you wish to receive when you issue operational commands. You can specify the entire routing matrix, the TX Matrix platform, a specific T640 routing node and its Flexible PIC Concentrators (FPCs), or a combination thereof.

Similarly, you can limit which portions of the routing matrix are modified during configuration or maintenance procedures (for example, performing software upgrades or halting Routing Engines).

Within the CLI, the TX Matrix platform is referenced by the term *switch-card chassis* (SCC) and the T640 routing nodes are known as *line-card chassis* (LCCs). As a result, you can use the `scc` and `lcc` options when you issue configuration and operational commands on the TX Matrix platform. If you do not specify one of these options, the generic form of a statement or command provides modification or display output for the entire routing matrix.



NOTE: This guide usually refers to LCCs as T640 routing nodes and the SCC as the TX Matrix platform.

System Requirements

To implement the TX Matrix platform, your system must meet these minimum requirements:

- JUNOS Release 7.0 or later
- One TX Matrix platform
- Two Juniper Networks T640 routing nodes
- Physical Interface Cards (PICs) of your choice (To view a list of supported PICs, see the *T640 Routing Node PIC Guide*)

Terms and Acronyms

- **switch-card chassis (SCC)**—A TX Matrix platform installed in a routing matrix.
- **line-card chassis (LCC)**—A T640 routing node installed in a routing matrix.
- **routing matrix**—A high capacity, multichassis routing platform that combines multiple T640 routing nodes with a TX Matrix platform switch fabric.
- **TX Matrix platform**—A high-speed centralized switch fabric that connects multiple T640 routing nodes in a routing matrix.
- **Switch Interface Board (SIB)**—On T640 routing nodes and the TX Matrix platform, a switch fabric plane component that forwards packets from a source Packet Forwarding Engine to a destination Packet Forwarding Engine in a routing matrix.

Configuring a Routing Matrix

When you configure a routing matrix, you need to be aware of several differences and similarities between a routing matrix and a standalone T640 routing node. To implement a routing matrix in your network, you must perform the following tasks:

- Adjusting the Configuration to Accommodate Increased FPC Numbers on page 126
- Configuring Groups to Support Routing Matrix Components on page 128
- Configuring Protocols and Other Features on page 129
- Option: Configuring Chassis-Specific Statements on page 130

To apply your knowledge, visit these sections:

- Example: Routing Matrix Configuration on page 131
- Checking Your Work on page 138

Adjusting the Configuration to Accommodate Increased FPC Numbers

A routing matrix can contain up to four T640 routing nodes, and each T640 routing node can contain up to eight FPCs (numbered 0 through 7). Therefore, the routing matrix as a whole can consist of up to 32 FPCs (numbered 0 through 31).

Each T640 routing node is assigned a number (LCCs 0 through 3) that depends upon the hardware setup and connectivity to the TX Matrix platform. Table 13 shows the basic correspondence between the FPC hardware slot numbers in T640 routing nodes and the FPC assignments recognized by a routing matrix.

Table 13: FPC Correspondence Between T640 Routing Nodes and the Routing Matrix

T640 Routing Node	T640 FPC Range	Routing Matrix FPC Range
LCC 0	0–7	0–7
LCC 1	0–7	8–15
LCC 2	0–7	16–23
LCC 3	0–7	24–31

To easily convert FPC numbers in the T640 routing nodes to the correct FPC number in a routing matrix, use the conversion chart shown in Table 14. You can use the converted FPC number to configure the interfaces on the TX Matrix platform in your routing matrix.

Table 14: T640 to Routing Matrix FPC Conversion Chart

FPC Numbering	T640 Routing Nodes								
	LCC 0								
T640 FPC Slots	0	1	2	3	4	5	6	7	
Routing Matrix FPC Slots Equivalent	0	1	2	3	4	5	6	7	
	LCC 1								
T640 FPC Slots	0	1	2	3	4	5	6	7	
Routing Matrix FPC Slots Equivalent	8	9	10	11	12	13	14	15	
	LCC 2								
T640 FPC Slots	0	1	2	3	4	5	6	7	
Routing Matrix FPC Slots Equivalent	16	17	18	19	20	21	22	23	
	LCC 3								
T640 FPC Slots	0	1	2	3	4	5	6	7	
Routing Matrix FPC Slots Equivalent	24	25	26	27	28	29	30	31	

For example, if you have a Gigabit Ethernet interface installed in FPC slot 7, PIC slot 0, port 0 of T640 routing node **LCC 3**, you can configure this interface on the TX Matrix platform by including the `ge-31/0/0` statement at the `[edit interfaces]` hierarchy level.

```
[edit]
interfaces {
  ge-31/0/0 {
    unit 0 {
      family inet {
        address ip-address;
      }
    }
  }
}
```

For more information about physically connecting T640 routing nodes and a TX Matrix platform together in a routing matrix, see the *TX Matrix Platform Hardware Guide*. For more information about the interface-naming conventions for a routing matrix, see the *JUNOS Network Interfaces Configuration Guide*.

Configuring Groups to Support Routing Matrix Components

For easy maintenance of chassis in a routing matrix, you can add a configuration group for each Routing Engine in the T640 routing nodes and TX Matrix platform. The configuration groups added to the TX Matrix platform configuration offer a simple way to establish hostnames, management interfaces, and default routes. In the example below, groups `re0` and `re1` refer to the TX Matrix platform Routing Engines, while groups `lcc0-re0` and `lcc0-re1` refer to the Routing Engines on T640 routing node LCC0. To configure groups for the TX Matrix platform, include the `re0` and `re1` statements at the `[edit groups]` hierarchy level. To configure groups for the T640 routing nodes, include the `lccnumber-re0` and `lccnumber-re1` statements at the `[edit groups]` hierarchy level.

```
[edit]
groups {
  re0 {
    system {
      host-name hostname-scc-re0;
      backup-router ip-address;
    }
    interfaces {
      fxp0 {
        unit 0 {
          family inet {
            address ip-address;
          }
        }
      }
    }
  }
  re1 {
    system {
      host-name hostname-scc-re1;
      backup-router ip-address;
    }
    interfaces {
      fxp0 {
        unit 0 {
          family inet {
            address ip-address;
          }
        }
      }
    }
  }
}
```

```

lcc0-re0 {
  system {
    host-name hostname-lcc0-re0;
    backup-router ip-address;
  }
  interfaces {
    fxp0 {
      unit 0 {
        family inet {
          address ip-address;
        }
      }
    }
  }
}
lcc0-re1 {
  system {
    host-name hostname-lcc0-re1;
    backup-router ip-address;
  }
  interfaces {
    fxp0 {
      unit 0 {
        family inet {
          address ip-address;
        }
      }
    }
  }
}
}
apply-groups [ re0 re1 lcc0-re0 lcc0-re1 ];

```

Note that apply groups can be nested. For example, any configuration statements that are common to `lcc0-re0` and `lcc0-re1` can be put into a separate group and then added as an apply group to the `lcc0-re0` and `lcc0-re1` groups, which in turn are applied to the main configuration.

For more information about configuration groups, see the *JUNOS CLI User Guide*.

Configuring Protocols and Other Features

Other than the expanded range of FPC numbers for interfaces and the requirement to create groups for the T640 routing nodes, the configuration of a routing matrix is exactly the same as for all other Juniper Networks routing platforms. As such, you can configure routing protocols, Multiprotocol Label Switching (MPLS) applications, virtual private networks (VPNs), routing and forwarding options, and other software features as usual.

For more information on configuring JUNOS-based routing platforms, see the JUNOS configuration guides.

Option: Configuring Chassis-Specific Statements

You can configure PIC-specific features, such as SONET/SDH framing, on specific T640 routing nodes within the routing matrix. To do so, include the `lcc lcc-number` statement at the `[edit chassis]` hierarchy level and specify the chassis-specific feature to configure.

```
[edit]
chassis {
  lcc lcc-number {
    fpc slot-number { # Use the T640 routing node FPC hardware slot number.
      pic pic-number {
        ...
      }
    }
  }
}
```



NOTE: When you include statements at the `[edit chassis lcc lcc-number]` hierarchy level, specify the actual FPC hardware slot number as labeled on the T640 routing node chassis. Do NOT use the routing matrix-based FPC number shown in Table 14 on page 127.

By default, the JUNOS software allows all T640 routing nodes in the routing matrix to come online. Optionally, you can configure the TX Matrix platform to generate an alarm if the T640 routing nodes in the routing matrix do not come online. To configure, include the `online-expected` statement at the `[edit chassis lcc number]` hierarchy level on the TX Matrix platform.

```
[edit chassis lcc number]
online-expected;
```

If you do not want a T640 routing node to be part of the routing matrix, you can configure it to be offline. This is useful when you are performing maintenance on a T640 routing node. To configure a T640 routing node so that it is offline, include the `offline` statement at the `[edit chassis lcc number]` hierarchy level.

```
[edit chassis lcc number]
offline;
```

When you are ready to bring the T640 routing node back online, delete the `offline` configuration statement at the `[edit chassis lcc number]` hierarchy level.



NOTE: If you do not configure the `online-expected` or `offline` statement, any T640 routing node that is part of the routing matrix is allowed to come online. However, if a T640 routing node does not come online, the TX Matrix platform does not generate an alarm.

For more information about chassis-specific statements, see the *JUNOS System Basics Configuration Guide*.

Example: Routing Matrix Configuration

Figure 15: Routing Matrix Topology Diagram

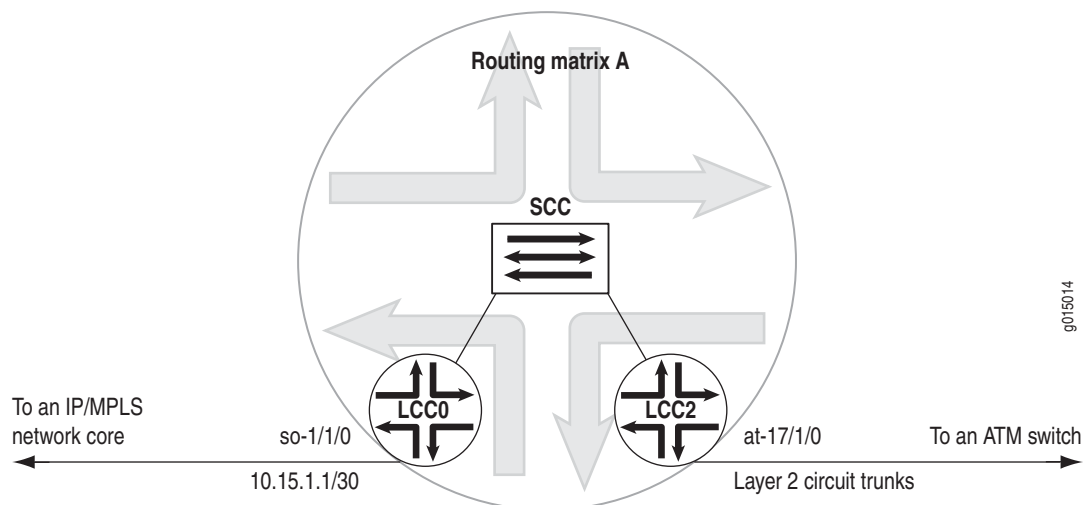

Figure 15 shows Routing Matrix A, a basic routing matrix consisting of a TX Matrix platform and two T640 routing nodes. The TX Matrix platform is named **SCC** and the nodes are named **LCC0** and **LCC2**. The routing matrix is acting as a provider edge (PE) router in a Layer 2 circuit network. SONET interface **so-1/1/0** in node **LCC0** connects to an IP/MPLS core network, and Asynchronous Transfer Mode 2 (ATM2) intelligent queuing (IQ) interface **at-17/1/0** in node **LCC2** runs Layer 2 circuit trunk mode to connect to an ATM switch. (For more information about Layer 2 circuit trunk mode, see “Option: Configuring Layer 2 Circuit Trunk Mode on ATM2 IQ Interfaces” on page 801 or the *JUNOS VPNs Configuration Guide*.)

Some key considerations for this configuration are as follows:

- Treat the routing matrix like a single routing platform and execute all configuration and operational commands on the TX Matrix platform **SCC**.
- Create configuration groups for each Routing Engine in the routing matrix by using groups **re0**, **re1**, **lcc0-re0**, **lcc2-re0**, **lcc0-re1**, and **lcc2-re1**. In the groups, configure hostnames, default routes, and management interfaces.
- To configure interfaces, use the routing matrix FPC numbering convention of slots 0 through 31.
- To enable ATM2 IQ trunk mode and other chassis-based commands, include the **lcc lcc-number** statement at the [edit chassis] hierarchy level and use the hardware FPC slot numbers 0 through 7 of node **LCC2**.
- Configure most other processes as usual, such as routing, class of service (CoS), and firewalls.

TX Matrix Platform—SCC

[edit]

groups { # You can create special configuration groups in a routing matrix.**re0** { # This group corresponds to the master Routing Engine

system { # on the TX Matrix platform.

host-name scc;

backup-router 192.168.17.254;

}

interfaces {

fxp0 {

unit 0 {

family inet {

address 192.168.77.158/21;

}

}

}

}

}

re1 { # This group corresponds to the backup Routing Engine

system { # on the TX Matrix platform.

host-name scc1;

backup-router 192.168.17.254;

}

interfaces {

fxp0 {

unit 0 {

family inet {

address 192.168.77.168/21;

}

}

}

}

}

lcc0-re0 { # This group corresponds to the master Routing Engine

system { # on the T640 routing node LCC0.

host-name lcc0;

backup-router 192.168.17.254 destination [10.0.0.0/8 192.168.0.0/16];

}

interfaces {

fxp0 {

unit 0 {

family inet {

address 192.168.77.157/21;

}

}

}

}

}

```

lcc2-re0 { # This group corresponds to the master Routing Engine
  system { # on the T640 routing node LCC2.
    host-name lcc2;
    backup-router 192.168.17.254 destination [10.0.0.0/8 192.168.0.0/16];
  }
  interfaces {
    fxp0 {
      unit 0 {
        family inet {
          address 192.168.77.159/21;
        }
      }
    }
  }
}
lcc0-re1 { # This group corresponds to the backup Routing Engine
  system { # on the T640 routing node LCC0.
    host-name lcc0-1;
    backup-router 192.168.17.254 destination [10.0.0.0/8 192.168.0.0/16];
  }
  interfaces {
    fxp0 {
      unit 0 {
        family inet {
          address 192.168.77.169/21;
        }
      }
    }
  }
}
lcc2-re1 { # This group corresponds to the backup Routing Engine
  system { # on the T640 routing node LCC2.
    host-name lcc2-1;
    backup-router 192.168.17.254 destination [10.0.0.0/8 192.168.0.0/16];
  }
  interfaces {
    fxp0 {
      unit 0 {
        family inet {
          address 192.168.77.192/21;
        }
      }
    }
  }
}
}
apply-groups [ re0 re1 lcc0-re1 lcc2-re1 lcc0-re0 lcc2-re0 ];
system {
  syslog {
    file messages {
      any any;
    }
  }
}
}

```

```

chassis { # You must apply chassis commands to a specific T640 routing node.
  lcc 2 { # Specify the T640 routing node and the FPC hardware slot of the node.
    fpc 1 { # This FPC is equivalent to slot 17 in the routing matrix.
      pic 1 {
        atm-l2circuit-mode {
          trunk nni;
        }
      }
    }
  }
}

interfaces {
  so-1/1/0 { # This is a SONET interface at FPC 1, PIC 1, port 0
    mtu 9192; # on the T640 routing node LCC0.
    unit 0 {
      family inet {
        address 10.15.1.1/30 {
          destination 10.15.1.2;
        }
      }
      family iso;
      family mpls {
        filter {
          input filter_1;
        }
      }
    }
  }
  at-17/1/0 { # This is an ATM2 IQ interface at FPC 1, PIC 1, port 0
    encapsulation atm-ccc-cell-relay; # on the T640 routing node LCC2.
    atm-options {
      pic-type atm2;
      scheduler-maps { # CoS on an ATM2 IQ PIC works the same in a routing matrix
        cos1 { # as it does in a standalone T640 routing node.
          forwarding-classubr {
            priority low;
            transmit-weight percent 25;
          }
          forwarding-classnrtvbr {
            priority low;
            transmit-weight percent 25;
          }
          forwarding-classrtvbr {
            priority low;
            transmit-weight percent 25;
          }
          forwarding-classcbr {
            priority high;
            transmit-weight percent 25;
          }
        }
      }
    }
  }
}

```

```

cos2 {
  forwarding-classubr {
    priority low;
    transmit-weight percent 10;
  }
  forwarding-classnrtvbr {
    priority low;
    transmit-weight percent 20;
  }
  forwarding-classrtvbr {
    priority low;
    transmit-weight percent 30;
  }
  forwarding-classcbr {
    priority high;
    transmit-weight percent 40;
  }
}
cos3 {
  forwarding-classubr {
    priority low;
    transmit-weight percent 40;
  }
  forwarding-classnrtvbr {
    priority low;
    transmit-weight percent 30;
  }
  forwarding-classrtvbr {
    priority low;
    transmit-weight percent 20;
  }
  forwarding-classcbr {
    priority high;
    transmit-weight percent 10;
  }
}
}
}
unit 0 {
  trunk-id 0;
  trunk-bandwidth 10m;
  cell-bundle-size 2;
}
unit 1 {
  trunk-id 1;
  trunk-bandwidth 10m;
  cell-bundle-size 1;
  atm-scheduler-map cos1;
}
unit 2 {
  trunk-id 2;
  trunk-bandwidth 10m;
  cell-bundle-size 2;
  atm-scheduler-map cos2;
}
}

```

```

    unit 3 {
        trunk-id 3;
        trunk-bandwidth 10m;
        cell-bundle-size 3;
        atm-scheduler-map cos3;
    }
}
lo0 {
    unit 0 {
        family inet {
            address 127.0.0.1/32;
            address 10.255.77.158/32 {
                primary;
            }
        }
        family iso {
            address 47.0005.80ff.f800.0000.0108.0001.0102.5507.0158.00;
        }
        family inet6 {
            address 2001:db8::10:255:77:158/32 {
                primary;
            }
        }
    }
}
}
protocols { # You can configure protocols in the routing matrix as usual.
    mpls {
        interface so-1/1/0.0;
    }
    isis {
        interface so-1/1/0.0;
        interface lo0.0;
    }
    ldp {
        interface so-1/1/0.0;
        interface lo0.0;
    }
    l2circuit {
        neighbor 10.255.71.97 {
            interface at-17/1/0.0 {
                virtual-circuit-id 100;
            }
            interface at-17/1/0.1 {
                virtual-circuit-id 101;
            }
            interface at-17/1/0.2 {
                virtual-circuit-id 102;
            }
            interface at-17/1/0.3 {
                virtual-circuit-id 103;
            }
        }
    }
}

```

```

class-of-service { # You can configure CoS in the routing matrix as usual.
  forwarding-classes {
    queue 0 ubr;
    queue 1 nrtvbr;
    queue 2 rtvbr;
    queue 3 cbr;
  }
  traceoptions {
    flag all;
  }
}
firewall { # You can configure firewalls in the routing matrix as usual.
  family mpls {
    filter filter_1 {
      term plp0 {
        from {
          exp [ 0 2 4 6 ];
        }
        then {
          count LOW;
          loss-priority low;
        }
      }
      term plp1 {
        from {
          exp [ 1 3 5 7 ];
        }
        then {
          count HIGH;
          loss-priority high;
        }
      }
    }
  }
}

```

Checking Your Work

To verify proper operation of the routing matrix, use the following commands on the TX Matrix platform:

- `show chassis alarms <lcc lcc-number | scc>`
- `show chassis craft-interface <lcc lcc-number | scc>`
- `show chassis ethernet-switch <lcc lcc-number | scc>`
- `show chassis hardware <lcc lcc-number | scc>`
- `show chassis fpc <lcc lcc-number>`
- `show chassis lccs`
- `show chassis location <fpc | interface | lcc lcc-number | scc>`
- `show chassis routing-engine <lcc lcc-number | scc>`
- `show chassis sibs <lcc lcc-number | scc>`
- `show interfaces terse`
- `show route summary`
- `show system uptime <all-lcc | lcc lcc-number | scc>`
- `show version <all-lcc | lcc lcc-number | scc>`

In general, when you issue standard operational commands on a TX Matrix platform, you receive output from the primary Routing Engines of all components in the routing matrix. To limit the output of information for a specific T640 routing node within the routing matrix, include the `lcc lcc-number` option. To display information for the TX Matrix platform only, include the `scc` option. To display information for all T640 routing nodes within the routing matrix (selected commands only), include the `all-lcc` option. Any exceptions to this general rule are mentioned next to the appropriate commands.

The following sections show the output of select operational commands used with the configuration example:

- [Displaying the Software Version on page 139](#)
- [Displaying Interfaces on page 141](#)
- [Displaying Routes on page 142](#)
- [Displaying Alarms and System Uptime on page 143](#)
- [Displaying Chassis Hardware and Status on page 146](#)
- [Other Miscellaneous Commands on page 153](#)

Displaying the Software Version

The `show version` command provides an excellent example of how you can select output for various components of the routing matrix. If the TX Matrix platform (SCC) or a T640 routing node (LCC) is not specified in the command, then the command displays output for all components.

```
user@router> show version ?
Possible completions:
<[Enter]>      Execute this command
all-lcc       Show software version on all LCC chassis
brief        Display brief output
detail       Display detailed output
lcc          Show software version on specific LCC (0..3)
scc          Show software version on the SCC
|            Pipe through a command
```

To display the software version for all routing matrix components, issue the `show version` command on the TX Matrix platform:

```
user@router> show version
scc-re0:
-----
Hostname: scc
Model: TX Matrix
JUNOS Base OS boot [7.0-20040630.0]
JUNOS Base OS Software Suite [7.0-20040629.0]
JUNOS Kernel Software Suite [7.0-20040630.0]
JUNOS Packet Forwarding Engine Support (T-Series) [7.0-20040630.0]
JUNOS Routing Software Suite [7.0-20040630.0]
JUNOS Online Documentation [7.0-20040630.0]
JUNOS Crypto Software Suite [7.0-20040630.0]

lcc0-re0:
-----
Hostname: lcc0
Model: t640
JUNOS Base OS boot [7.0-20040630.0]
JUNOS Base OS Software Suite [7.0-20040629.0]
JUNOS Kernel Software Suite [7.0-20040630.0]
JUNOS Packet Forwarding Engine Support (T-Series) [7.0-20040630.0]
JUNOS Routing Software Suite [7.0-20040630.0]
JUNOS Online Documentation [7.0-20040630.0]
JUNOS Crypto Software Suite [7.0-20040630.0]
JUNOS Support Tools Package [7.0-20040630.0]

lcc2-re0:
-----
Hostname: lcc2
Model: t640
JUNOS Base OS boot [7.0-20040630.0]
JUNOS Base OS Software Suite [7.0-20040629.0]
JUNOS Kernel Software Suite [7.0-20040630.0]
JUNOS Packet Forwarding Engine Support (T-Series) [7.0-20040630.0]
JUNOS Routing Software Suite [7.0-20040630.0]
JUNOS Online Documentation [7.0-20040630.0]
JUNOS Crypto Software Suite [7.0-20040630.0]
JUNOS Support Tools Package [7.0-20040630.0]
```

To display the software version for the TX Matrix platform only, include the `scc` option:

```
user@router> show version scc
Hostname: scc
Model: TX Matrix
JUNOS Base OS boot [7.0-20040630.0]
JUNOS Base OS Software Suite [7.0-20040629.0]
JUNOS Kernel Software Suite [7.0-20040630.0]
JUNOS Packet Forwarding Engine Support (T-Series) [7.0-20040630.0]
JUNOS Routing Software Suite [7.0-20040630.0]
JUNOS Online Documentation [7.0-20040630.0]
JUNOS Crypto Software Suite [7.0-20040630.0]
```

To display the software version for a specific T640 routing node, include the `lcc` option:

```
user@router> show version lcc 0
lcc0-re0:
-----
Hostname: lcc0
Model: t640
JUNOS Base OS boot [7.0-20040630.0]
JUNOS Base OS Software Suite [7.0-20040629.0]
JUNOS Kernel Software Suite [7.0-20040630.0]
JUNOS Packet Forwarding Engine Support (T-Series) [7.0-20040630.0]
JUNOS Routing Software Suite [7.0-20040630.0]
JUNOS Online Documentation [7.0-20040630.0]
JUNOS Crypto Software Suite [7.0-20040630.0]
JUNOS Support Tools Package [7.0-20040630.0]
```

To display the output for all T640 routing nodes, include the `all-lcc` option:

```
user@router> show version all-lcc
lcc0-re0:
-----
Hostname: lcc0
Model: t640
JUNOS Base OS boot [7.0-20040630.0]
JUNOS Base OS Software Suite [7.0-20040629.0]
JUNOS Kernel Software Suite [7.0-20040630.0]
JUNOS Packet Forwarding Engine Support (T-Series) [7.0-20040630.0]
JUNOS Routing Software Suite [7.0-20040630.0]
JUNOS Online Documentation [7.0-20040630.0]
JUNOS Crypto Software Suite [7.0-20040630.0]
JUNOS Support Tools Package [7.0-20040630.0]

lcc2-re0:
-----
Hostname: lcc2
Model: t640
JUNOS Base OS boot [7.0-20040630.0]
JUNOS Base OS Software Suite [7.0-20040629.0]
JUNOS Kernel Software Suite [7.0-20040630.0]
JUNOS Packet Forwarding Engine Support (T-Series) [7.0-20040630.0]
JUNOS Routing Software Suite [7.0-20040630.0]
JUNOS Online Documentation [7.0-20040630.0]
JUNOS Crypto Software Suite [7.0-20040630.0]
JUNOS Support Tools Package [7.0-20040630.0]
```

Displaying Interfaces

Although individual FPCs are installed in each of the T640 routing nodes, the routing matrix is designed to collect interface information centrally at the TX Matrix platform. To display available interfaces in the routing matrix, issue a `show interfaces` command on the TX Matrix platform:

```

user@router> show interfaces terse
Interface           Admin Link Proto Local           Remote
so-1/0/0            up   up
so-1/1/0            up   up
so-1/1/0.0          up   up   inet 10.15.1.1     --> 10.15.1.2
                   up   up   iso
                   up   up   mpls

so-1/3/0            up   down
at-2/1/0            up   up
ge-2/2/0            up   up
so-3/3/0            up   up
so-3/3/1            up   up
so-3/3/2            up   down
so-3/3/3            up   down
so-16/0/0           up   down
so-16/0/1           up   down
so-16/0/2           up   down
so-16/0/3           up   up
ge-16/1/0           up   down
so-17/0/0           up   down
at-17/1/0           up   up
at-17/1/0.0         up   up   ccc
at-17/1/0.1         up   up   ccc
at-17/1/0.2         up   up   ccc
at-17/1/0.3         up   up   ccc
at-17/1/1           up   up
ge-17/2/0           up   up
ge-17/2/1           up   up
so-17/3/0           up   down
so-19/0/0           up   down
so-19/1/0           up   down
so-19/2/0           up   down
so-19/3/0           up   down
bcm0                up   up
bcm0.0              up   up   tnp 4
dsc                 up   up
em0                 up   up
em0.0               up   up   tnp 4
fxp0                up   up
fxp0.0              up   up   inet 192.168.77.158/21
gre                 up   up
ipip                up   up
lo0                 up   up
lo0.0               up   up   inet 10.255.70.158   --> 0/0
                   up   up   inet 127.0.0.1        --> 0/0
                   up   up   iso
47.0005.80ff.f800.0000.0108.0001.0102.5507.0158.00
                   up   up   inet6 2001:db8::10:255:70:158
                   up   up   inet6 fe80::280:42ff:fe13:269d
lo0.16385           up   up   inet
                   up   up   inet6 fe80::280:42ff:fe13:269d

lsi                 up   up
mtun                up   up
pimd                up   up
pime                up   up
tap                 up   up

```

Displaying Routes

When you need to verify route information for a routing matrix, you must issue operational commands on the TX Matrix platform. To display available routes for the routing matrix, issue a `show route` command:

```

user@router> show route summary
Router ID: 10.255.77.158

inet.0: 13 destinations, 14 routes (12 active, 0 holddown, 1 hidden)
  Direct:    4 routes,    3 active
  Local:    2 routes,    2 active
  Static:   6 routes,    6 active
  IS-IS:    2 routes,    1 active

inet.3: 1 destinations, 1 routes (1 active, 0 holddown, 0 hidden)
  LDP:      1 routes,    1 active

iso.0: 1 destinations, 1 routes (1 active, 0 holddown, 0 hidden)
  Direct:   1 routes,    1 active

mpls.0: 7 destinations, 7 routes (7 active, 0 holddown, 0 hidden)
  MPLS:    3 routes,    3 active
  LDP:     2 routes,    2 active
  L2CKT:   2 routes,    2 active

inet6.0: 2 destinations, 2 routes (2 active, 0 holddown, 0 hidden)
  Direct:  2 routes,    2 active

__juniper_private1__.inet6.0: 1 destinations, 1 routes (1 active, 0 holddown, 0
hidden)
  Direct:  1 routes,    1 active

l2circuit.0: 5 destinations, 5 routes (5 active, 0 holddown, 0 hidden)
  LDP:     1 routes,    1 active
  L2CKT:   4 routes,    4 active

```

Displaying Alarms and System Uptime

To display alarms for all routing matrix components, issue the `show chassis alarms` command:

```
user@router> show chassis alarms
scc-re0:
-----
2 alarms currently active
Alarm time          Class  Description
2004-09-27 08:50:57 PDT Major  LCC 2 Major Errors
2004-09-27 08:50:42 PDT Minor  LCC 0 Minor Errors

lcc0-re0:
-----
1 alarms currently active
Alarm time          Class  Description
2004-09-27 08:50:42 PDT Minor  PEM 1 Absent

lcc2-re0:
-----
1 alarms currently active
Alarm time          Class  Description
2004-09-27 08:50:57 PDT Major  PEM 1 Not OK
```

To display the craft interface display for all routing matrix components, issue the `show chassis craft-interface` command:

```
user@router> show chassis craft-interface
scc-re0:
-----
FPM Display contents:
+-----+
|scc      |
|2 Alarms active |
|R: LCC 2 Major Error|
|Y: LCC 0 Minor Error|
+-----|

Front Panel System LEDs:
Routing Engine  0  1
-----
OK              *  *
Fail            .  .
Master          *  .

Front Panel Alarm Indicators:
-----
Red LED        *
Yellow LED     *
Major relay    *
Minor relay    *

CB LEDs:
  CB  0  1
-----
Amber  .  .
Green  *  *
Blue   *  .
```

```
SIB LEDs:
  SIB  0  1  2  3  4
-----
Fail   .  .  .  .  .
OK     *  *  *  *  *
Active .  *  *  *  *
```

lcc0-re0:

```
FPM Display contents:
+-----+
|lcc0          |
|1 Alarm active |
|Y: PEM 1 Absent|
|              |
+-----+
```

```
Front Panel System LEDs:
Routing Engine  0  1
-----
OK              *  *
Fail            .  .
Master          *  .
```

```
Front Panel Alarm Indicators:
-----
Red LED        .
Yellow LED     *
Major relay    .
Minor relay    *
```

```
Front Panel FPC LEDs:
FPC  0  1  2  3  4  5  6  7
-----
Red   .  .  .  .  .  .  .  .
Green .  *  *  *  .  .  .  .
```

```
CB LEDs:
  CB  0  1
-----
Amber .  .
Green *  *
Blue  *  .
```

```
SCG LEDs:
  SCG 0  1
-----
Amber .  .
Green *  *
Blue  *  .
```

```
SIB LEDs:
  SIB  0  1  2  3  4
-----
Red   .  .  .  .  .
Green *  *  *  *  *
```

1cc2-re0:

FPM Display contents:

```
+-----+
|1cc2      |
|1 Alarm active |
|R: PEM 1 Not OK |
|          |
+-----+
```

Front Panel System LEDs:

Routing Engine	0	1
OK	*	*
Fail	.	.
Master	*	.

Front Panel Alarm Indicators:

Red LED	*
Yellow LED	.
Major relay	*
Minor relay	.

Front Panel FPC LEDs:

FPC	0	1	2	3	4	5	6	7
Red
Green	*	*	.	*

CB LEDs:

CB	0	1
Amber	.	.
Green	*	*
Blue	*	.

SCG LEDs:

SCG	0	1
Amber	.	.
Green	*	.
Blue	*	.

SIB LEDs:

SIB	0	1	2	3	4
Red
Green	*	*	*	*	*

To display the amount of time the routing matrix components have been in operation, issue the `show system uptime` command on the TX Matrix platform:

```

user@router> show system uptime
scc-re0:
-----
Current time: 2004-09-27 09:44:55 PDT
System booted: 2004-09-27 08:49:31 PDT (00:55:24 ago)
Protocols started: 2004-09-27 08:50:27 PDT (00:54:28 ago)
Last configured: 2004-09-27 09:16:08 PDT (00:28:47 ago) by regress
9:44AM PDT up 55 mins, 1 user, load averages: 0.00, 0.05, 0.06

lcc0-re0:
-----
Current time: 2004-09-27 09:44:55 PDT
System booted: 2004-09-27 08:49:24 PDT (00:55:31 ago)
Last configured: 2004-09-27 09:16:06 PDT (00:28:49 ago) by regress
9:44AM PDT up 56 mins, 0 users, load averages: 0.00, 0.02, 0.00

lcc2-re0:
-----
Current time: 2004-09-27 09:44:55 PDT
System booted: 2004-09-27 08:49:26 PDT (00:55:29 ago)
Last configured: 2004-09-27 09:16:06 PDT (00:28:49 ago) by regress
9:44AM PDT up 55 mins, 0 users, load averages: 0.02, 0.01, 0.00

```

Displaying Chassis Hardware and Status

To display the hardware inventory for a routing matrix, you can select output for the TX Matrix platform only, a specific T640 routing node, or all components. If a specific component (lcc or scc) is not specified as an option in the command, the default output displays information for the entire routing matrix.

```

user@router> show chassis hardware ?
Possible completions:
<[Enter]>          Execute this command
detail            Include RAM and disk information in output
extensive         Display ID EEPROM information
frus              Display assembly IDs and extra PIC information
lcc              Display chassis-specific information (0..3)
scc              Display chassis-specific information
|                Pipe through a command

```

To display all hardware components in a routing matrix, issue the `show chassis hardware` command on the TX Matrix platform:

```
user@router> show chassis hardware
```

```
scc-re0:
```

```
-----  
Hardware inventory:
```

Item	Version	Part number	Serial number	Description
Chassis				TX Matrix
Midplane	REV 04	710-004396	RB0013	SCC Midplane
FPM GBUS				
FPM Display	REV 04	710-004619	HS5953	SCC FPM
CIP 0	REV 01	710-010218	HS5726	SCC CIP
CIP 1	REV 01	710-010218	HV9163	SCC CIP
PEM 0	Rev 11	740-002595	pm18529	Power Entry Module
Routing Engine 0	REV 02	740-008883	212058900121	RE-4.0
Routing Engine 1	REV 03	740-008883	211123900258	RE-4.0
CB 0	REV 01	710-011709	HS5911	Control Board (CB-TX)
CB 1	REV 01	710-011709	HZ2163	Control Board (CB-TX)
SPMB 0	REV 09	710-003229	HT4129	T-series Switch CPU
SPMB 1	REV 09	710-003229	HT4174	T-series Switch CPU
SIB 0	REV 01	710-011223	HS0663	SIB-S8-F16 1/2
B Board	REV 05	710-011225	HW1210	SIB-S8-F16 1/2 (B)
SIB 1	REV 01	710-005839	HW1160	SIB-S8-F16
B Board	REV 01	710-005840	HW1213	SIB-S8-F16 (B)
SIB 2	REV 05	710-011223	HW1146	SIB-S8-F16 1/2
B Board	REV 05	710-011225	JB8148	SIB-S8-F16 1/2 (B)
SIB 3	REV 05	710-011223	HW1218	SIB-S8-F16 1/2
B Board	REV 05	710-011225	HW1214	SIB-S8-F16 1/2 (B)
SIB 4	REV 05	710-011223	HW1162	SIB-S8-F16 1/2
B Board	REV 05	710-011225	HW1182	SIB-S8-F16 1/2 (B)

tcc0-re0:

Hardware inventory:

Item	Version	Part number	Serial number	Description
Chassis			65409	T640
Midplane	REV 03	710-005608	RA1395	T640 Backplane
FPM GBUS	REV 09	710-002901	RA2649	T640 FPM Board
FPM Display	REV 05	710-002897	RA2608	FPM Display
CIP	REV 06	710-002895	HS0753	T-series CIP
PEM 0	Rev 01	740-002595	MF16629	Power Entry Module
SCG 0	REV 11	710-003423	HS4313	T640 Sonet Clock Gen.
SCG 1	REV 11	710-003423	HR9161	T640 Sonet Clock Gen.
Routing Engine 0	REV 03	740-008883	211123900199	RE-4.0
Routing Engine 1	REV 03	740-008883	211123900248	RE-4.0
CB 0	REV 02	710-007655	HS5909	Control Board (CB-T)
CB 1	REV 02	710-007655	HS5910	Control Board (CB-T)
FPC 1	REV 07	710-007527	HR0716	FPC Type 2
CPU	REV 15	710-001726	HS6048	FPC CPU
PIC 0	REV 07	750-001900	AR3722	1x OC-48 SONET, SMSR
PIC 1	REV 05	750-001900	AD3644	1x OC-48 SONET, SMSR
PIC 3	REV 06	750-001900	HD7603	1x OC-48 SONET, SMSR
MMB 1	REV 03	710-005555	HT5273	MMB-288mbit
PPB 0	REV 04	710-003758	HR4249	PPB Type 2
PPB 1	REV 04	710-003758	HR4257	PPB Type 2
FPC 2	REV 01	710-010233	HM4189	E-FPC Type 1
CPU	REV 01	710-010169	HS9936	FPC CPU-Enhanced
PIC 1	REV 03	750-005719	HL8326	1x OC-12 ATM-II IQ, MM
PIC 2	REV 01	750-003141	AD9051	1x G/E, 1000 BASE-SX
MMB 1	REV 01	710-008923	HR0848	MMB 3M 288-bit
FPC 3	REV 01	710-010154	HR0863	E-FPC Type 3
CPU	REV 01	710-010169	HN3422	FPC CPU-Enhanced
PIC 3	REV 01	750-009553	HP3576	4x OC-48 SONET
SFP 0	REV 01	740-009030	P11H5N1	SFP-LR
SFP 1	REV 01	740-009029	35D464P00060	SFP-IR
SFP 3	REV 01	740-009030	P11H5LM	SFP-LR
MMB 0	REV 01	710-010171	HR0821	MMB-288mbit
MMB 1	REV 01	710-010171	HR0818	MMB-288mbit
SPMB 0	REV 09	710-003229	HT4177	T-series Switch CPU
SPMB 1	REV 09	710-003229	HT4176	T-series Switch CPU
SIB 0	REV 07	710-005781	HR5939	SIB-L8-F16
B Board	REV 06	710-005782	HR5944	SIB-L8-F16 (B)
SIB 1	REV 02	710-005781	HZ2146	SIB-L8-F16
B Board	REV 03	710-005782	HY4160	SIB-L8-F16 (B)
SIB 2	REV 07	710-005781	HR5925	SIB-L8-F16
B Board	REV 03	710-005782	HY4161	SIB-L8-F16 (B)
SIB 3	REV 07	710-005781	HR5918	SIB-L8-F16
B Board	REV 06	710-005782	HR5972	SIB-L8-F16 (B)
SIB 4	REV 07	710-005781	HR5935	SIB-L8-F16
B Board	REV 06	710-005782	HR5969	SIB-L8-F16 (B)

tcc2-re0:

Hardware inventory:

Item	Version	Part number	Serial number	Description
Chassis			55609	T640
Midplane	REV 03	710-005608	RA1444	T640 Backplane
FPM GBUS	REV 09	710-002901	RA3309	T640 FPM Board
FPM Display	REV 05	710-002897	RA3273	FPM Display
CIP	REV 06	710-002895	HS0735	T-series CIP
PEM 0	Rev 11	740-002595	PM18568	Power Entry Module
PEM 1	Rev 11	740-002595	PM18572	Power Entry Module
SCG 0	REV 11	710-003423	HS9991	T640 Sonet Clock Gen.
Routing Engine 0	REV 03	740-008883	211123900183	RE-4.0

Routing Engine 1	REV 02	740-008883	212058900178	RE-4.0
CB 0	REV 02	710-007655	HS5913	Control Board (CB-T)
CB 1	REV 02	710-007655	HS5944	Control Board (CB-T)
FPC 0	REV 05	710-001721	HD5965	FPC Type 3
CPU	REV 09	710-001726	AY4909	FPC CPU
PIC 0	REV 04	750-009553	HV3648	4x OC-48 SONET
SFP 0	REV 01	740-009029	P11JXWP	SFP-IR
SFP 1	REV 01	740-008169	36D525P00154	UNKNOWN
SFP 2	REV 01	740-009028	2353110	SFP-SR
SFP 3	REV 01	740-008169	36D525P00159	UNKNOWN
PIC 1	REV 02	750-009567	HX2875	1x 10GE(LAN),XENPAK
SFP 0	REV 01	740-009898	USC202YW25	XENPAK-LR
MMB 0	REV 03	710-004047	HE3427	MMB-288mbit
MMB 1	REV 03	710-004047	HD5812	MMB-288mbit
ICBM	REV 04	710-003384	HB1884	FPC ICBM
PPB 0	REV 02	710-002845	HC0964	PPB Type 3
PPB 1	REV 02	710-002845	HC0987	PPB Type 3
FPC 1	REV 02	710-002385	HC0618	FPC Type 2
CPU	REV 06	710-001726	HA4724	FPC CPU
PIC 0	REV 02	750-009066	HL9900	1x OC-48 SONET SFP
SFP 0		NON-JNPR	P11QS8W	SFP-LR
PIC 1	REV 02	750-007219	AZ1339	2x OC-12 ATM-II IQ, MM
PIC 2	REV 02	750-002510	AP7476	2x G/E, 1000 BASE-SX
PIC 3	REV 05	750-001900	AD5738	1x OC-48 SONET, SMSR
MMB 1	REV 03	710-004047	HD5829	MMB-288mbit
ICBM	REV 04	710-003384	HC0386	FPC ICBM
PPB 0	REV 02	710-003758	HC0904	PPB Type 2
PPB 1	REV 02	710-003758	HC0898	PPB Type 2
FPC 3	REV 07	710-007529	HR3311	FPC Type 3
CPU	REV 15	710-001726	HR2788	FPC CPU
PIC 0	REV 10	750-004535	HT0545	1x OC-192 SM SR2
PIC 1	REV 12	750-004535	HX2065	1x OC-192 SM SR2
PIC 2	REV 01	750-004535	HC0241	1x OC-192 SM SR1
PIC 3	REV 01	750-004535	HF6583	1x OC-192 SM SR1
MMB 0	REV 03	710-005555	HR5642	MMB-288mbit
MMB 1	REV 03	710-005555	HR5586	MMB-288mbit
PPB 0	REV 04	710-002845	HT6719	PPB Type 3
PPB 1	REV 04	710-002845	HMO206	PPB Type 3
SPMB 0	REV 09	710-003229	HR8685	T-series Switch CPU
SPMB 1	REV 09	710-003229	HR3730	T-series Switch CPU
SIB 0	REV 07	710-005781	HR5937	SIB-L8-F16
B Board	REV 06	710-005782	HZ5288	SIB-L8-F16 (B)
SIB 1	REV 07	710-005781	HZ5279	SIB-L8-F16
B Board	REV 06	710-005782	HR5951	SIB-L8-F16 (B)
SIB 2	REV 07	710-005781	HZ5276	SIB-L8-F16
B Board	REV 06	710-005782	HR5950	SIB-L8-F16 (B)
SIB 3	REV 07	710-005781	HR5915	SIB-L8-F16
B Board	REV 06	710-005782	HZ5285	SIB-L8-F16 (B)
SIB 4	REV 07	710-005781	HR5934	SIB-L8-F16
B Board	REV 06	710-005782	HR5952	SIB-L8-F16 (B)

You can also display individual hardware components in the TX Matrix platform, a specific T640 routing node, or the entire routing matrix. To display all the SIBs in the entire routing matrix, issue the `show chassis sibs` command on the TX Matrix platform.

```
user@router> show chassis sibs
scc-re0:
-----
Slot  State                Uptime
 0      Spare
 1      Online                53 minutes, 38 seconds
```

```

2   Online          53 minutes, 36 seconds
3   Online          53 minutes, 33 seconds
4   Online          53 minutes, 30 seconds

```

1cc0-re0:

```

-----
Slot State          Uptime
0   Spare
1   Online          53 minutes, 18 seconds
2   Online          53 minutes, 17 seconds
3   Online          53 minutes, 16 seconds
4   Online          53 minutes, 15 seconds

```

1cc2-re0:

```

-----
Slot State          Uptime
0   Spare
1   Online          53 minutes, 18 seconds
2   Online          53 minutes, 17 seconds
3   Online          53 minutes, 16 seconds
4   Online          53 minutes, 15 seconds

```

To display information about all master Routing Engines in the routing matrix, issue the `show chassis routing-engine` command on the TX Matrix platform:

```

user@router> show chassis routing-engine

```

scc-re0:

Routing Engine status:

Slot 0:

```

Current state          Master
Election priority      Master (default)
Temperature            34 degrees C / 93 degrees F
CPU temperature        35 degrees C / 95 degrees F
DRAM                  2048 MB
Memory utilization     12 percent
CPU utilization:
  User                 0 percent
  Background           0 percent
  Kernel               5 percent
  Interrupt            0 percent
  Idle                 95 percent
Model                 RE-4.0
Serial ID              212058900121
Start time             2004-09-27 08:49:31 PDT
Uptime                 1 hour, 4 seconds
Load averages:        1 minute  5 minute 15 minute
                      0.06      0.04    0.05

```

Routing Engine status:

Slot 1:

```

Current state          Backup
Election priority      Backup (default)
Temperature            33 degrees C / 91 degrees F
CPU temperature        34 degrees C / 93 degrees F
DRAM                  2048 MB
Memory utilization     10 percent
CPU utilization:
  User                 0 percent
  Background           0 percent
  Kernel               0 percent
  Interrupt            1 percent
  Idle                 99 percent

```

```

Model                RE-4.0
Serial ID            211123900258
Start time           2004-09-26 13:09:13 PDT
Uptime               20 hours, 40 minutes, 4 seconds

```

lcc0-re0:

Routing Engine status:

Slot 0:

```

Current state        Master
Election priority    Master (default)
Temperature          37 degrees C / 98 degrees F
CPU temperature      38 degrees C / 100 degrees F
DRAM                 2048 MB
Memory utilization   11 percent
CPU utilization:
  User               0 percent
  Background         0 percent
  Kernel             3 percent
  Interrupt          1 percent
  Idle               97 percent
Model                RE-4.0
Serial ID            211123900199
Start time           2004-09-27 08:49:24 PDT
Uptime               1 hour, 11 seconds
Load averages:      1 minute  5 minute 15 minute
                   0.02      0.02   0.00

```

Routing Engine status:

Slot 1:

```

Current state        Backup
Election priority    Backup (default)
Temperature          35 degrees C / 95 degrees F
CPU temperature      35 degrees C / 95 degrees F
DRAM                 2048 MB
Memory utilization   10 percent
CPU utilization:
  User               0 percent
  Background         0 percent
  Kernel             0 percent
  Interrupt          0 percent
  Idle               99 percent
Model                RE-4.0
Serial ID            211123900248
Start time           2004-09-26 13:09:07 PDT
Uptime               20 hours, 40 minutes, 12 seconds

```

lcc2-re0:

Routing Engine status:

Slot 0:

```

Current state        Master
Election priority    Master (default)
Temperature          33 degrees C / 91 degrees F
CPU temperature      35 degrees C / 95 degrees F
DRAM                 2048 MB
Memory utilization   11 percent
CPU utilization:
  User               0 percent
  Background         0 percent
  Kernel             4 percent
  Interrupt          0 percent
  Idle               96 percent
Model                RE-4.0

```

```

Serial ID                211123900183
Start time              2004-09-27 08:49:26 PDT
Uptime                 1 hour, 9 seconds
Load averages:         1 minute   5 minute  15 minute
                       0.15      0.05    0.01

Routing Engine status:
Slot 1:
  Current state         Backup
  Election priority     Backup (default)
  Temperature           32 degrees C / 89 degrees F
  CPU temperature       34 degrees C / 93 degrees F
  DRAM                  2048 MB
  Memory utilization    10 percent
  CPU utilization:
    User                0 percent
    Background          0 percent
    Kernel              0 percent
    Interrupt           1 percent
    Idle                99 percent
  Model                RE-4.0
  Serial ID            212058900178
  Start time           2004-09-26 13:09:10 PDT
  Uptime               20 hours, 40 minutes, 8 seconds
    
```

To display information about FPCs in a routing matrix, issue the `show chassis fpc` command. Because there are no FPCs in a TX Matrix platform, there is no `scc` option available for this command.

```

user@router> show chassis fpc
lcc0-re0:
-----
Slot State      Temp  CPU Utilization (%)  Memory  Utilization (%)
                (C)   Total Interrupt      DRAM (MB) Heap      Buffer
0 Empty
1 Online        31    1      0      256      7      44
2 Online        28    1      0      256      7      44
3 Online        31    3      0      256     14      44
4 Empty
5 Empty
6 Empty
7 Empty

lcc2-re0:
-----
Slot State      Temp  CPU Utilization (%)  Memory  Utilization (%)
                (C)   Total Interrupt      DRAM (MB) Heap      Buffer
0 Online        31    3      0      256     14      44
1 Online        30    2      0      256      7      44
2 Empty
3 Online        31    3      0      256     14      44
4 Empty
5 Empty
6 Empty
7 Empty
    
```

You can also check to see if the TX Matrix platform and T640 routing nodes are communicating correctly within the routing matrix. To verify that the T640 routing nodes have proper connectivity to the routing matrix, issue the `show chassis lccs` command. In this example, there are two T640 routing nodes in the routing matrix.

```

user@router> show chassis lccs
Slot  State                Uptime
 0    Online                52 minutes, 5 seconds
 1    Empty
 2    Online                52 minutes, 6 seconds
 3    Empty

```

Other Miscellaneous Commands

There are a variety of other useful commands you can use when maintaining a routing matrix.

- To display the location of routing matrix components and convert FPCs from T640 routing node local numbering to routing matrix global numbering, issue the `show chassis location fpc` command on the TX Matrix platform:

```

user@router> show chassis location fpc
Global FPC   LCC   Local FPC
 1           0     1
 2           0     2
 3           0     3
16          2     0
17          2     1
19          2     3

```

- To check the status of the SIB connection between the TX Matrix platform and T640 routing nodes, issue the `show chassis fabric topology` command on the TX Matrix platform. All values for each available T640 routing node (LCC) should be in the UP state. In the following excerpt of output for this command, a routing matrix that contains only LCCs 0 and 2 shows only these two T640 routing nodes as being UP:

```

LCC0_SIB-L0_F0,03->SIB-S0_F0,00 UP
LCC1_SIB-L0_F0,03->SIB-S0_F0,01 RESET
LCC2_SIB-L0_F0,03->SIB-S0_F0,02 UP
LCC3_SIB-L0_F0,03->SIB-S0_F0,03 RESET

```

- To verify that the Ethernet links between the TX Matrix platform and the T640 routing node control boards are operational, issue the `show chassis ethernet-switch` command on the TX Matrix platform:

```

user@router> show chassis ethernet-switch
scc-re0:
-----
Link is good on FE port 4 connected to device: LCC0
Speed is 100Mb
Duplex is full
Autonegotiate is Enabled

Link is good on FE port 6 connected to device: LCC2
Speed is 100Mb
Duplex is full
Autonegotiate is Enabled

Link is good on FE port 8 connected to device: SPMB
Speed is 100Mb
Duplex is full
Autonegotiate is Enabled

```

```
Link is good on GE port 13 connected to device: Other RE
Speed is 1000Mb
Duplex is full
Autonegotiate is Enabled
```

```
lcc0-re0:
```

```
-----
Link is good on FE port 1 connected to device: FPC1
Speed is 100Mb
Duplex is full
Autonegotiate is Enabled
```

```
Link is good on FE port 2 connected to device: FPC2
Speed is 100Mb
Duplex is full
Autonegotiate is Enabled
```

```
Link is good on FE port 3 connected to device: FPC3
Speed is 100Mb
Duplex is full
Autonegotiate is Enabled
```

```
Link is good on FE port 8 connected to device: SPMB
Speed is 100Mb
Duplex is full
Autonegotiate is Enabled
```

```
Link is good on FE port 10 connected to device: SCC
Speed is 100Mb
Duplex is full
Autonegotiate is Enabled
```

```
Link is good on GE port 13 connected to device: Other RE
Speed is 100Mb
Duplex is full
Autonegotiate is Enabled
```

```
lcc2-re0:
```

```
-----
Link is good on FE port 0 connected to device: FPC0
Speed is 100Mb
Duplex is full
Autonegotiate is Enabled
```

```
Link is good on FE port 1 connected to device: FPC1
Speed is 100Mb
Duplex is full
Autonegotiate is Enabled
```

```
Link is good on FE port 3 connected to device: FPC3
Speed is 100Mb
Duplex is full
Autonegotiate is Enabled
```

```
Link is good on FE port 8 connected to device: SPMB
Speed is 100Mb
Duplex is full
Autonegotiate is Enabled
```

```
Link is good on FE port 10 connected to device: SCC
Speed is 100Mb
Duplex is full
Autonegotiate is Enabled
```

```

Link is good on GE port 13 connected to device: Other RE
Speed is 100Mb
Duplex is full
Autonegotiate is Enabled

```

Routing Matrix Hardware and Software Considerations

When you implement a routing matrix, pay close attention to the following considerations:

- Identifying Routing Matrix Components on page 155
- Viewing the Routing Matrix as a Single Routing Platform on page 156
- Connecting to a Routing Matrix on page 156
- Committing Configurations on a Routing Matrix on page 157
- Upgrading the Software for a Routing Matrix on page 158
- Managing System Processes in the Routing Matrix on page 162
- Rebooting and Halting Routing Matrix Components on page 163
- Enabling and Disabling Specific Routing Matrix Hardware Components on page 164
- Managing Files on Routing Engines in a Routing Matrix on page 166

Identifying Routing Matrix Components

A routing matrix contains two type of chassis:

- TX Matrix platform

There is only one TX Matrix platform per routing matrix. It is referred to as the switch-card chassis (scc) in the JUNOS CLI.

- T640 routing nodes

There can be one to four T640 routing nodes in a routing matrix. These are referred to as line-card chassis 0 through 3 (lcc0–lcc3) in the JUNOS CLI. The T640 routing node number is set by the hardware. See the *TX Matrix Platform Hardware Guide* for further information on installing and connecting the hardware.

Viewing the Routing Matrix as a Single Routing Platform

Even though a routing matrix can comprise five separate physical components (a TX Matrix platform and up to four T640 routing nodes), it is best if you consider a routing matrix as a single routing platform. When you issue configuration and operational commands on the TX Matrix platform, your view of the routing matrix shows a single routing device with a high number of FPCs and PICs. For a detailed discussion of FPC numbering in a routing matrix, see “Adjusting the Configuration to Accommodate Increased FPC Numbers” on page 126.

Connecting to a Routing Matrix

The TX Matrix platform and every T640 routing node can each be configured with two Routing Engines to provide redundancy and graceful Routing Engine switchover capabilities. You can connect to each Routing Engine in the following ways:

- Console/AUX—Asynchronous access via the console and auxiliary ports on the TX Matrix platform or T640 routing node Connector Interface Panel (CIP).
- Management Ethernet—Telnet access via the Fast Ethernet ports on the TX Matrix platform or T640 routing node CIPs.
- CLI login from one Routing Engine to another—All Routing Engines in the routing matrix are connected to their respective control boards, which in turn are connected to the CIP on the TX Matrix platform (see the *TX Matrix Platform Hardware Guide* for more details). After you log in to one Routing Engine, you can connect to another Routing Engine as follows:

```

user@router> request routing-engine login ?
Possible completions:
  backup          Log in to backup RE
  lcc             Log in to LCC (0..3)
  master         Log in to master RE
  other-routing-engine Log in to the other Routing Engine
  re0            Log in to RE0
  re1            Log in to RE1
user@router> request routing-engine login lcc ?
Possible completions:
<lcc>           Log in to LCC (0..3)
user@router> request routing-engine login lcc 0 ?
Possible completions:
  backup          Log in to backup RE
  master         Log in to master RE
  re0            Log in to RE0
  re1            Log in to RE1

```



NOTE: Because the routing matrix appears as a single routing platform, we recommend that you access the master Routing Engine of the TX Matrix platform to perform all configuration tasks for the routing matrix. Under normal operating conditions, you do not need to access or configure the T640 routing nodes directly. If you access a Routing Engine on a T640 routing node, the following warning is displayed:

```
user@router> request routing-engine login lcc 0 re0

--- JUNOS 7.0-20040625.1 built 2004-06-25 19:51:38 UTC

%
% cli
warning: This chassis is a Line Card Chassis (LCC) in a multichassis
system.
warning: Use of interactive commands should be limited to debugging.
warning: Normal CLI access is provided by the Switch Card Chassis (SCC).
warning: Use 'request routing-engine login scc' to log into the SCC.
```

To manage the backup Routing Engines on all components (for example, to upgrade JUNOS software), log in to the TX Matrix platform backup Routing Engine and perform the necessary operations.

Committing Configurations on a Routing Matrix

You must commit configuration changes for a routing matrix on the TX Matrix platform rather than on the individual T640 routing nodes. If you commit a configuration directly on a T640 routing node within a routing matrix, the configuration is not distributed to the TX Matrix platform or the other T640 routing nodes in the routing matrix. Conversely, all configuration changes you commit on the TX Matrix platform are distributed to all the T640 routing nodes in the routing matrix and override any changes committed directly on a T640 routing node.

There are two main ways to commit configurations on a TX Matrix platform. When you issue the `commit synchronize` command, you synchronize the configurations of both the primary and backup Routing Engines on the TX Matrix platform and the primary and backup Routing Engines of all the associated T640 routing nodes.

```
user@router# commit synchronize
scc-re0:
configuration check succeeds
lcc0-re1:
commit complete
lcc0-re0:
commit complete
lcc1-re1:
commit complete
lcc1-re0:
commit complete
scc-re1:
commit complete
scc-re0:
commit complete
```

If you issue the basic form of the `commit` command on the TX Matrix platform, this action updates only the master Routing Engines of the TX Matrix platform and the T640 routing nodes in the routing matrix.

```
user@router# commit
scc-re0:
configuration check succeeds
lcc0-re0:
commit complete
lcc1-re0:
commit complete
scc-re0:
commit complete
```

Upgrading the Software for a Routing Matrix

By default, when you upgrade software on the TX Matrix platform, the new image is loaded onto the TX Matrix platform and distributed to all T640 routing nodes in the routing matrix. To upgrade software for the entire routing matrix, issue the `request system software add` command:

```
user@router> request system software add
jbundle-7.0-20040705.0-domestic-signed.tgz
Pushing bundle to lcc0-re0
Pushing bundle to lcc1-re0
Validating on lcc0-re0
Checking compatibility with configuration
Initializing...
Using jbase-7.0-20040629.0
Using /var/tmp/jbundle-7.0-20040705.0-domestic-signed.tgz
Using /var/validate/tmp/jbundle-signed/jbundle-7.0-20040705.0-domestic.tgz
Checking jbundle requirements on /
Available space: 64513 require: 31626
Using /var/validate/tmp/jbundle/jbase-7.0-20040705.0.tgz
Using /var/validate/tmp/jbundle/jkernel-7.0-20040705.0.tgz
Using /var/validate/tmp/jbundle/jcrypto-7.0-20040705.0.tgz
Using /var/validate/tmp/jbundle/jpfe-7.0-20040705.0.tgz
Using /var/validate/tmp/jbundle/jdocs-7.0-20040705.0.tgz
Using /var/validate/tmp/jbundle/jroute-7.0-20040705.0.tgz
Validating against /config/juniper.conf.gz
mgd: commit complete
Validation succeeded

Validating on lcc1-re0
Checking compatibility with configuration
Initializing...
Using jbase-7.0-20040629.0
Using /var/tmp/jbundle-7.0-20040705.0-domestic-signed.tgz
inform: not found
Using /var/validate/tmp/jbundle-signed/jbundle-7.0-20040705.0-domestic.tgz
Checking jbundle requirements on /
Available space: 64510 require: 31626
Using /var/validate/tmp/jbundle/jbase-7.0-20040705.0.tgz
Using /var/validate/tmp/jbundle/jkernel-7.0-20040705.0.tgz
Using /var/validate/tmp/jbundle/jcrypto-7.0-20040705.0.tgz
Using /var/validate/tmp/jbundle/jpfe-7.0-20040705.0.tgz
Using /var/validate/tmp/jbundle/jdocs-7.0-20040705.0.tgz
Using /var/validate/tmp/jbundle/jroute-7.0-20040705.0.tgz
Validating against /config/juniper.conf.gz
mgd: commit complete
Validation succeeded
```

```

Validating on scc-re0
Checking compatibility with configuration
Initializing...
Using jbase-7.0-20040629.0
Using /var/tmp/jbundle-7.0-20040705.0-domestic-signed.tgz
Using /var/validate/tmp/jbundle-signed/jbundle-7.0-20040705.0-domestic.tgz
Checking jbundle requirements on /
Available space: 165275 require: 31626
Using /var/validate/tmp/jbundle/jbase-7.0-20040705.0.tgz
Using /var/validate/tmp/jbundle/jkernel-7.0-20040705.0.tgz
Using /var/validate/tmp/jbundle/jcrypto-7.0-20040705.0.tgz
Using /var/validate/tmp/jbundle/jpfe-7.0-20040705.0.tgz
Using /var/validate/tmp/jbundle/jdocs-7.0-20040705.0.tgz
Using /var/validate/tmp/jbundle/jroute-7.0-20040705.0.tgz
Validating against /config/juniper.conf.gz
mgd: commit complete
Validation succeeded
Done with validate on all chassis

lcc0-re0:
Installing package '/var/tmp/jbundle-7.0-20040705.0-domestic-signed.tgz' ...
Verified SHA1 checksum of jbundle-7.0-20040705.0-domestic.tgz
Adding jbundle...
Available space: 64513 require: 31626
Verified SHA1 checksum of jbase-7.0-20040705.0.tgz
Verified SHA1 checksum of jboot-7.0-20040705.0
Verified SHA1 checksum of jcrypto-7.0-20040705.0.tgz
Verified SHA1 checksum of jdocs-7.0-20040705.0.tgz
Verified SHA1 checksum of jkernel-7.0-20040705.0.tgz
Verified SHA1 checksum of jpfe-7.0-20040705.0.tgz
Verified SHA1 checksum of jroute-7.0-20040705.0.tgz
Mounted jboot on /mnt (/dev/vn7)
Updating root filesystem...
Unmounted /mnt
Auto-deleting old jroute...
Auto-deleting old jdocs...
Auto-deleting old jpfe...
Auto-deleting old jcrypto...
Auto-deleting old jkernel...
Auto-deleting old jbase...
Adding jbase...

WARNING:   A reboot is required to load this software correctly
WARNING:   Use the 'request system reboot' command
WARNING:   when software installation is complete

Adding jkernel...
Mounted jkernel package on /dev/vn7...
Adding jcrypto...
Mounted jcrypto package on /dev/vn8...
Adding jpfe...
Mounted jpfe package on /dev/vn2...
Adding jdocs...
Mounted jdocs package on /dev/vn9...
Adding jroute...
Mounted jroute package on /dev/vn10...
Saving package file in
/var/sw/pkg/jbundle-7.0-20040705.0-domestic-signed.tgz ...
Saving state for rollback ...

```

```
lcc1-re0:
Installing package '/var/tmp/jbundle-7.0-20040705.0-domestic-signed.tgz' ...
Verified SHA1 checksum of jbundle-7.0-20040705.0-domestic.tgz
Adding jbundle...
Available space: 64510 require: 31626
Verified SHA1 checksum of jbase-7.0-20040705.0.tgz
Verified SHA1 checksum of jboot-7.0-20040705.0
Verified SHA1 checksum of jcrypto-7.0-20040705.0.tgz
Verified SHA1 checksum of jdocs-7.0-20040705.0.tgz
Verified SHA1 checksum of jkernel-7.0-20040705.0.tgz
Verified SHA1 checksum of jpfe-7.0-20040705.0.tgz
Verified SHA1 checksum of jroute-7.0-20040705.0.tgz
Mounted jboot on /mnt (/dev/vn7)
Updating root filesystem...
Unmounted /mnt
Auto-deleting old jroute...
Auto-deleting old jdocs...
Auto-deleting old jpfe...
Auto-deleting old jcrypto...
Auto-deleting old jkernel...
Auto-deleting old jbase...
Adding jbase...

WARNING:      A reboot is required to load this software correctly
WARNING:      Use the 'request system reboot' command
WARNING:      when software installation is complete

Adding jkernel...
Mounted jkernel package on /dev/vn7...
Adding jcrypto...
Mounted jcrypto package on /dev/vn8...
Adding jpfe...
Mounted jpfe package on /dev/vn2...
Adding jdocs...
Mounted jdocs package on /dev/vn9...
Adding jroute...
Mounted jroute package on /dev/vn10...
Saving package file in
/var/sw/pkg/jbundle-7.0-20040705.0-domestic-signed.tgz ...
Saving state for rollback ...
```

```

scc-re0:
Installing package '/var/tmp/jbundle-7.0-20040705.0-domestic-signed.tgz' ...
Verified SHA1 checksum of jbundle-7.0-20040705.0-domestic.tgz
Adding jbundle...
Available space: 165275 require: 31626
Verified SHA1 checksum of jbase-7.0-20040705.0.tgz
Verified SHA1 checksum of jboot-7.0-20040705.0
Verified SHA1 checksum of jcrypto-7.0-20040705.0.tgz
Verified SHA1 checksum of jdocs-7.0-20040705.0.tgz
Verified SHA1 checksum of jkernel-7.0-20040705.0.tgz
Verified SHA1 checksum of jpfe-7.0-20040705.0.tgz
Verified SHA1 checksum of jroute-7.0-20040705.0.tgz
NOTICE: uncommitted changes have been saved in
/var/db/config/juniper.conf.pre-install
Mounted jboot on /mnt (/dev/vn6)
Updating root filesystem...
Unmounted /mnt
Auto-deleting old jroute...
Auto-deleting old jdocs...
Auto-deleting old jpfe...
Auto-deleting old jcrypto...
Auto-deleting old jkernel...
Auto-deleting old jbase...
Adding jbase...

WARNING:      A reboot is required to load this software correctly
WARNING:      Use the 'request system reboot' command
WARNING:      when software installation is complete

Adding jkernel...
Mounted jkernel package on /dev/vn6...
Adding jcrypto...
Mounted jcrypto package on /dev/vn7...
Adding jpfe...
Mounted jpfe package on /dev/vn2...
Adding jdocs...
Mounted jdocs package on /dev/vn8...
Adding jroute...
Mounted jroute package on /dev/vn9...
Saving package file in
/var/sw/pkg/jbundle-7.0-20040705.0-domestic-signed.tgz ...
Saving state for rollback ...

```

When you complete the software installation and reboot the TX Matrix platform, all T640 routing nodes also reboot and all devices in the routing matrix execute the new software.

To upgrade the backup Routing Engines, log in to the backup Routing Engine on the TX Matrix platform before you issue the `request system software add` command.

You can also update the software on the TX Matrix platform only or on a specific T640 routing node as needed by including the `lcc` or `scc` option.



NOTE: The master Routing Engines in all components of a routing matrix must run the same version of software in order to operate. As a result, we recommend that you upgrade all components simultaneously and upgrade individual components only in rare cases.

Managing System Processes in the Routing Matrix

Some system processes in a routing matrix run on the TX Matrix platform and some run on the T640 routing nodes. For example, the routing protocol process (rpd) runs exclusively on the TX Matrix platform. To restart the routing protocol process for the entire routing matrix, issue the **restart routing** command on the TX Matrix platform.

```
user@router> restart routing ?
Possible completions:
<[Enter]>      Execute this command
gracefully    Gracefully restart the process
immediately    Immediately restart (SIGKILL) the process
logical-router Name of logical router
soft          Soft reset (SIGHUP) the process
|            Pipe through a command
```

Other processes run on both the TX Matrix platform and the T640 routing nodes. To restart the chassis process that manages PICs, FPCs, and other hardware components, issue the **restart chassis-control** command on the TX Matrix platform and select the **all**, **all-lcc**, or **lcc *lcc-number*** option.

```
user@router> restart chassis-control ?
Possible completions:
<[Enter]>      Execute this command
all           Restart software process on all chassis
all-lcc       Restart software process on all LCC chassis
gracefully    Gracefully restart the process
immediately    Immediately restart (SIGKILL) the process
lcc           Restart software process on specific chassis (0..3)
soft          Soft reset (SIGHUP) the process
|            Pipe through a command
```

To restart the Simple Network Management Protocol (SNMP) process, issue the **restart snmp** command on the TX Matrix platform and select the **all**, **all-lcc**, or **lcc *lcc-number*** option.

```
user@router> restart snmp ?
Possible completions:
<[Enter]>      Execute this command
all           Restart software process on all chassis
all-lcc       Restart software process on all LCC chassis
gracefully    Gracefully restart the process
immediately    Immediately restart (SIGKILL) the process
lcc           Restart software process on specific chassis (0..3)
soft          Soft reset (SIGHUP) the process
|            Pipe through a command
```

Rebooting and Halting Routing Matrix Components

You can control which component in a routing matrix is rebooted or halted. If you reboot or halt the TX Matrix platform, by default you also reboot or halt the master Routing Engines on all T640 routing nodes. To reboot a specific component, issue the `request system reboot` command with the `all-lcc`, `lcc`, or `scc` option.

```
user@router> request system reboot ?
Possible completions:
<[Enter]>      Execute this command
all-lcc        Reboot all LCC chassis
at             Time at which to perform the operation
in            Number of minutes to delay before operation
lcc           Reboot LCC (0..3)
media         Boot media for next boot
message       Message to display to all users
scc           Reboot SCC chassis
|            Pipe through a command

user@router> request system reboot
Reboot the system ? [yes,no] (no) yes
```

```
Rebooting lcc0-re0
```

```
Rebooting lcc1-re0
```

Similarly, to halt a specific component in a routing matrix, issue the `request system halt` command with the `all-lcc`, `lcc`, or `scc` option.

```
user@router> request system halt ?
Possible completions:
<[Enter]>      Execute this command
all-lcc        Halt all LCC chassis
at             Time at which to perform the operation
both-routing-engines Halt both Routing Engines
in            Number of minutes to delay before operation
lcc           Halt LCC (0..3)
media         Boot media for next boot
message       Message to display to all users
scc           Halt SCC
|            Pipe through a command
```

Issuing the `request system halt both-routing-engines` command on a TX Matrix platform halts both Routing Engines in the TX Matrix platform and both Routing Engines in all T640 routing nodes in the routing matrix.

Enabling and Disabling Specific Routing Matrix Hardware Components

You can temporarily disable certain hardware components (such as FPCs, PICs, and SIBs) that belong to the TX Matrix platform and T640 routing nodes in the routing matrix. To do so, issue the appropriate `request chassis` command and include the `lcc` or `scc` option as needed.



NOTE: If you issue a chassis-related command that references FPCs, we recommend that you use the FPC hardware slot number (0 through 7) of the specific T640 routing node and specify its corresponding LCC number.

```

user@router> request chassis ?
Possible completions:
cb                Change Control Board status
fpc               Change Flexible PIC Concentrator status
fpm              Change craft interface status
lcc              Change LCC status
pic              Change Physical Interface Card status
routing-engine   Change Routing Engine status
scg              Change SONET Clock Generator status
sib              Change Switch Interface Board status
spmb             Change Switch Processor Mezzanine Board status

user@router> request chassis fpc ?
Possible completions:
lcc              Slot number of LCC that houses FPC (0..3)
offline          Take FPC offline
online           Bring FPC online
restart          Restart FPC
slot             FPC slot number (0..31)

user@router> request chassis pic ?
Possible completions:
fpc-slot         Slot number of FPC that houses PIC (0..31)
lcc              Slot number of LCC that houses FPC (0..3)
offline          Take PIC offline
online           Bring PIC online
pic-slot         PIC slot number (0..3)

user@router> request chassis sib ?
Possible completions:
lcc              Change Switch Interface Board status (0..3)
offline          Take SIB offline
online           Bring SIB online
scc              Change Switch Interface Board status
slot             SIB slot number (0..4)
start-receiver   Start SIB optical receiver (0..3)
stop-receiver    Stop SIB optical receiver (0..3)

```

The routing matrix extends the concept of taking specific hardware components offline or online to include an entire T640 routing node in a routing matrix. To enable or disable a T640 routing node in a routing matrix, issue the `request chassis lcc slot lcc-number (offline | online)` command.

```

user@router> request chassis lcc ?
Possible completions:
offline          Take LCC offline
online           Bring LCC online
slot             LCC Slot (0..3)

```

Although you can enter the routing matrix-based slot number when you issue the `request chassis fpc` command, output from `show chassis` commands always references the FPC hardware slot number (0 through 7) of the specific T640 routing node and its corresponding LCC number. As a result, we recommend that you include the FPC hardware slot number when you issue `request chassis` or `show chassis` commands, as shown in the following example:

First, issue the `request chassis fpc` command with the routing matrix-based FPC slot number of 19:

```
user@router> request chassis fpc offline slot 19
lcc2-re0:
-----
Offline initiated, use "show chassis fpc" to verify
```

However, when you issue the `show chassis fpc` command to check the result, the output displays the change using node-centric terminology: FPC slot number 3 on T640 routing node LCC2 (the equivalent of routing matrix slot 19).

```
user@router> show chassis fpc
lcc0-re0:
-----
Slot State      Temp  CPU Utilization (%)  Memory  Utilization (%)
                (C)  Total  Interrupt           DRAM (MB) Heap    Buffer
0 Empty
1 Online        31    2      0      256      7      44
2 Online        28    1      0      256      7      44
3 Online        31    2      0      256     14      44
4 Empty
5 Empty
6 Empty
7 Empty

lcc2-re0:
-----
Slot State      Temp  CPU Utilization (%)  Memory  Utilization (%)
                (C)  Total  Interrupt           DRAM (MB) Heap    Buffer
0 Online        31    2      0      256     14      44
1 Online        30    2      0      256      7      44
2 Empty
3 Offline      --- Offlined by cli command ---
4 Empty
5 Empty
6 Empty
7 Empty
```

To bring the same FPC back online, use the slot number and LCC number from the previous command output:

```
user@router> request chassis fpc online lcc 2 slot 3
lcc2-re0:
-----
Online initiated, use "show chassis fpc" to verify
```

Once you bring the FPC back online, reissue the `show chassis fpc` command to see that the FPC slot and LCC number you used in the last command now matches the command output:

```
user@router> show chassis fpc
lcc0-re0:
-----
Slot State      Temp  CPU Utilization (%)  Memory  Utilization (%)
              (C)  Total  Interrupt           DRAM (MB) Heap      Buffer
0 Empty
1 Online        31    1      0                256     7        44
2 Online        28    1      0                256     7        44
3 Online        31    3      0                256    14        44
4 Empty
5 Empty
6 Empty
7 Empty
```

```
lcc2-re0:
-----
Slot State      Temp  CPU Utilization (%)  Memory  Utilization (%)
              (C)  Total  Interrupt           DRAM (MB) Heap      Buffer
0 Online        31    3      0                256    14        44
1 Online        30    1      0                256     7        44
2 Empty
3 Present        0    0      0                 0         0         0
4 Empty
5 Empty
6 Empty
7 Empty
```

For more information about converting FPC hardware slot numbers on a T640 routing node to routing matrix FPC slot numbers, see “Adjusting the Configuration to Accommodate Increased FPC Numbers” on page 126.

Managing Files on Routing Engines in a Routing Matrix

You can manage files on all Routing Engines in a routing matrix. For example, you can copy a file from the master Routing Engine in the TX Matrix platform to the master Routing Engine on a T640 routing node.

```
user@router> file list lcc0-re0:
/var/home/user/lcc0-re0: No such file or directory

user@router> file list

/var/home/user/:
.ssh/
fred.txt

user@host> file copy fred.txt lcc0-re0:fred.txt

user@host> file list lcc0-re0:
lcc0-re0:
-----
/var/home/user/:
.ssh/
fred.txt
```

For More Information

For additional information about the routing matrix, see the following:

- *TX Matrix Platform Hardware Guide*
- *JUNOS Network Interfaces Configuration Guide*
- *JUNOS System Basics Configuration Guide*
- *JUNOS CLI User Guide*
- *JUNOS Interfaces Command Reference*
- *JUNOS Routing Protocols and Policies Command Reference*
- *JUNOS System Basics and Services Command Reference*

Revision History

12 January 2007—8.2R1 Release. Fawn Damitio.

15 September 2006—8.1R1 Release. Richard Hendricks.

29 June 2006—8.0R1 Release. Richard Hendricks.

27 March 2006—7.6R1 Release. Richard Hendricks.

9 January 2006—7.5R1 Release. Richard Hendricks.

14 September 2005—7.4R1 Release. Richard Hendricks.

13 June 2005—7.3R1 Release. Richard Hendricks.

5 April 2005—7.2R1 Release. Richard Hendricks.

2 February 2005—7.1R1 Release. Richard Hendricks.

6 October 2004— Release 7.0R1, initial revision. Gary Matthews and Richard Hendricks.

