

Chapter 7

Connecting IPv6 Islands with IPv4 MPLS

Many service providers are looking for ways to provide new revenue-generating services to their customers. One such service is Internet Protocol version 6 (IPv6). Some enterprise customers are beginning to experiment with this new version of IP, but are reluctant to deploy it broadly. Interconnecting multiple sites that use IPv6 can be challenging. Also, most service providers would prefer to carry this traffic without making major modifications to their core network.

A technique available in JUNOS Release 5.4 allows you to connect IPv6 sites over an IPv4 Multiprotocol Label Switching (MPLS) enabled backbone. Juniper Networks supports the Multiprotocol Border Gateway Protocol (MP-BGP) over IPv4 approach detailed in the Internet Engineering Task Force (IETF) Internet draft *draft-ietf-ngtrans-bgp-tunnel-04.txt, Connecting IPv6 Domains across IPv4 Clouds with BGP* (expires July 2002). With this technique, IPv6 islands are connected to each other across an IPv4 backbone enabled with MPLS label stacking while MP-BGP is used to announce the IPv6 routes across these MPLS tunnels. This feature can be implemented with label-switched paths (LSPs) using the Label Distribution Protocol (LDP) or Resource Reservation Protocol (RSVP).

IPv6 packets are carried over an IPv4 MPLS tunnel. To enable this service, you need to deploy provider edge (PE) routers that can run IPv4, MPLS, and BGP toward the core and IPv6 toward the edge. Since only the PE routers need to run a dual stack of IPv4 and IPv6, the other provider (P) core routers do not need to be upgraded. As a result, this MPLS tunneling technique allows for interoperability with routers from other vendors.

Because of this flexible method of implementation, it is now more attractive for providers to carry IPv6 traffic over their existing core networks and for customers to roll out IPv6 to more sites.

This feature guide covers these topics:

- Overview on page 314
- System Requirements on page 316
- Terms and Acronyms on page 316

- Configuring an IPv4 MPLS Tunnel to Carry IPv6 Traffic on page 316
 - Example: Connecting IPv6 Islands over an MPLS Tunnel Configuration on page 318
 - Checking Your Work on page 325
- For More Information on page 329
- Revision History on page 330

Overview

In Figure 33, PE1 and PE2 are dual-stack Border Gateway Protocol (DS-BGP) routers. They implement IPv4 and IPv6 stacks simultaneously. The IPv6 clouds are separate islands that are connected to PE routers through a customer edge (CE) router.

This example shows how to enable IPv6 connectivity between the various IPv6 islands, not how to create an IPv6 VPN service. One of the IPv6 islands can be the global IPv6 Internet.

The connection between the CE and PE routers can use any network layer protocol that carries IPv6 traffic. The provider router can exchange information with the customer routers using IPv6-enabled routing protocols, such as RIPng or MP-BGP, or static routes. The PE routers use IPv6 on the CE-facing interfaces, but use IPv4, BGP, and MPLS to connect to the core.

You must configure appropriate export policies on the PE router to share route information between IBGP and EBGP, and between BGP and other protocols.

Figure 33: Connecting IPv6 Islands over MPLS

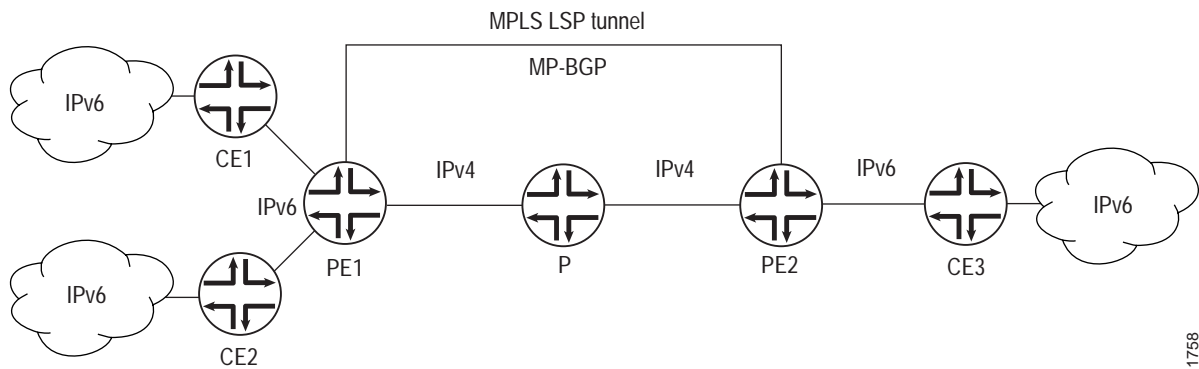

Because MP-BGP requires that a BGP next hop use the same address family as the Network Layer Reachability Information (NLRI), the IPv4 address needs to be embedded in an IPv6 format. Such IPv4-mapped IPv6 addresses are defined in RFC 3513, *IP Version 6 Addressing Architecture*. After the PE routers learn the IPv6 routes from their directly attached CE neighbors, each PE router uses its own IPv4 address as the next hop for the IPv6 routes that are advertised in the BGP session.

1758

The two PE routers establish an MP-BGP session with each other using IPv4 addresses. In the session, the routers exchange IPv6 routes with an IPv6 address family identifier (AFI) value of 2 and a subsequent AFI (SAFI) label with a value of 4. Labels with a value of 2 are explicit null labels for IPv6, as defined in RFC3032. Before sending IPv6 traffic across the IPv4 MPLS tunnel, the PE attaches the two labels. The inner label is 2 (another value if the advertising PE router is not a Juniper router) and the outer label is the LSP label.

A PE router must have MPLS LSPs pointing to the other peer PE router's IPv4 address. The LSPs are signaled across the IPv4 control plane using either LDP or RSVP. These LSPs resolve the next-hop addresses of the IPv6 routes learned through MP-BGP. The next hops are actually IPv4-mapped IPv6 addresses, while the LSPs are associated with IPv4 addresses. Because of this mapping technique, the IPv6 traffic can travel over the IPv4 LSP transparently.

In Figure 33 on page 314, PE1 receives an IPv6 packet from CE1 and performs a lookup in the IPv6 forwarding table. If the destination matches a prefix that was learned from CE2, no labels are necessary and the IPv6 packet is sent to CE2. If the destination matches a prefix that was learned from PE2, then PE1 places two labels on the packet and sends it to P. The inner label is 2 and the outer label is the LSP label needed to reach PE2. Since P is the penultimate-hop router for the LSP to PE2 and the received packet has more than one label, Router P pops the outer label and sends the packet to PE2. When PE2 receives the packet, it has a single label with a value of 2. PE2 strips off the label and treats the remaining packet as an IPv6 packet (since 2 is the IPv6 explicit null label) and performs a lookup in the IPv6 forwarding table.

Although the MP-BGP over IPv4 approach can operate using a single level of labels, there is an advantage in using two labels. The penultimate-hop router for the MPLS LSP (P in this case) can pop the outer label and send the packet with the inner label as an MPLS packet. When the packet arrives at egress Router PE2, the second label using the explicit null value is popped and the remaining IPv6 packet is sent to the directly connected IPv6 network. Thus, the benefit of using two labels is that penultimate hop-popping (PHP) routers do not require IPv6 capabilities or the need for an upgrade.

Interconnecting IPv6 islands over an IPv4 MPLS tunnel requires:

- An exchange of IPv6 reachability information between DS-BGP routers. Using MP-BGP, the DS-BGP (PE) routers exchange IPv6 reachability information over the IPv4 core network with other similarly enabled DS-BGP PE peers. As a result, the egress DS-BGP (PE) router announces itself as the BGP next hop.
- IPv6 packets are tunneled from the ingress DS-BGP router to the egress DS-BGP router by means of MPLS. The ingress DS-BGP router tunnels an IPv6 packet over the IPv4 network toward the egress DS-BGP router identified as the BGP next hop for the packet's destination IPv6 address.

System Requirements

To carry IPv6 traffic over IPv4 MPLS tunnels, your system must meet these minimum requirements:

- JUNOS Release 7.2 or later for J-series Services Routers
- JUNOS Release 5.4 or later for M-series and T-series routing platforms
- Two Juniper Networks J-series, M-series, or T-series routing platforms to act as the DS-BGP ingress and egress devices

Terms and Acronyms

- **dual-stack BGP (DS-BGP)**—A router that processes IPv4 and IPv6 packets in a BGP-connected network.
- **Multiprotocol BGP (MP-BGP)**—A router that processes packets from a variety of protocols in a BGP-connected network.
- **Subsequent Address Family Identifier (SAFI)**—A field in Multiprotocol BGP messages that identifies MPLS network layer reachability information (NLRI). Common values include 1 (unicast), 2 (multicast), and 4 (MPLS label).

Configuring an IPv4 MPLS Tunnel to Carry IPv6 Traffic

To enable IPv6 to be carried over an IPv4 MPLS tunnel, perform the following tasks:

- [Configuring IPv6 on the Customer and Core-Facing Interfaces on page 317](#)
- [Configuring MPLS and RSVP from PE Router to PE Router to Create a Tunnel on page 317](#)
- [Enabling IPv6 Tunneling in MPLS on page 317](#)
- [Configuring Multiprotocol BGP to Carry IPv6 Traffic on page 318](#)

To view a full configuration example, see these sections:

- [Example: Connecting IPv6 Islands over an MPLS Tunnel Configuration on page 318](#)
- [Checking Your Work on page 325](#)

Configuring IPv6 on the Customer and Core-Facing Interfaces

In addition to configuring family inet6 on all the CE-facing interfaces, you must also configure family inet6 on all the core-facing interfaces running MPLS. The router must be able to process any IPv6 packets it receives on these interfaces. You should not see any regular IPv6 traffic arrive on these interfaces, but you will receive MPLS packets tagged with label 2. Even though label 2 MPLS packets are sent in IPv4, these packets are treated as native IPv6 packets.

```
[edit]
interfaces {
  interface-name {
    unit unit-number {
      family inet6 {
        address inet6-address;
      }
    }
  }
}
```

Configuring MPLS and RSVP from PE Router to PE Router to Create a Tunnel

This guide assumes you already have experience configuring MPLS and RSVP. For more information about these topics, see the *JUNOS MPLS Applications Configuration Guide*.

Enabling IPv6 Tunneling in MPLS

Enter the ipv6-tunneling option on your PE routers at the [edit protocols mpls] hierarchy level:

```
[edit]
protocols {
  mpls {
    ipv6-tunneling;
  }
}
```

Configuring Multiprotocol BGP to Carry IPv6 Traffic

You can specify the family inet6 statement on a per-neighbor, per-group, or global basis. The statement allows BGP to carry IPv6 traffic.

At the appropriate global, group, or neighbor hierarchy level in BGP (shown below), configure the family inet6 statement with the labeled-unicast parameter and the explicit-null option. These additional parameters enable the IPv4 MPLS label to be removed at the destination PE router. The remaining label-less IPv6 packet can then be forwarded to the connected IPv6 network.

```
[edit protocols bgp] OR
[edit protocols bgp group group-name] OR
[edit protocols bgp group group-name neighbor neighbor-name]

family inet6 {
  labeled-unicast {
    explicit-null;
  }
}
```

Example: Connecting IPv6 Islands over an MPLS Tunnel Configuration

Figure 34: IPv6 over an MPLS Tunnel

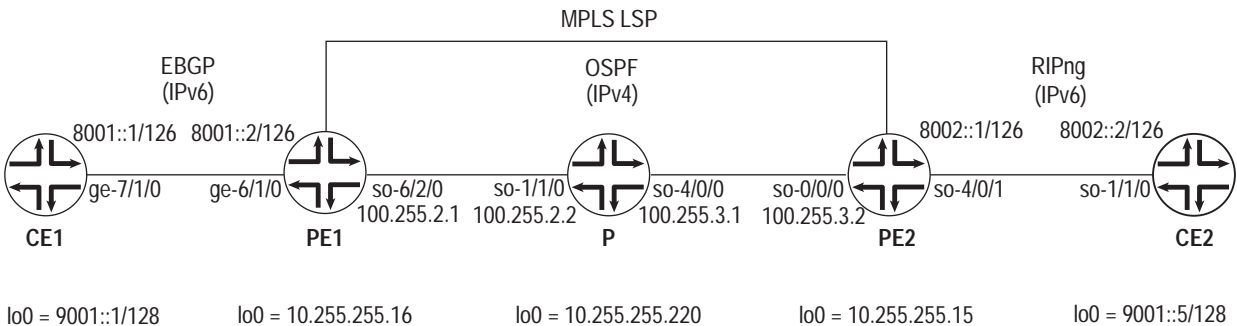

1757

Figure 34 shows a standard CE-PE-P-PE-CE MPLS-style network. CE1 and CE2 are the end customer CE routers using IPv6; PE1 and PE2 are the provider edge routers; and P is a provider core router. The IPv4 MPLS tunnel travels between PE1 and PE2, connecting IPv6 sites CE1 and CE2.

Since the CE-to-PE configuration can use a variety of routing protocols, this example requires that you use EBGP between CE1 and PE1 and RIPng between PE2 and CE2. You must establish policies on PE2 to import and export routes between BGP and RIPng.

To start the configuration, set up the IPv6 connection between CE1 and PE1. In your BGP routing policy, you must advertise the IPv6 loopback address of the CE1 router address to the PE1 router.

```

Router CE1 [edit]
interfaces {
  ge-7/1/0 {
    unit 0 {
      family inet6 {
        address 8001::1/126;
      }
    }
  }
  lo0 {
    unit 0 {
      family inet6 {
        address 9001::1/128;
      }
    }
  }
}
routing-options {
  autonomous-system 200;
}
protocols {
  bgp {
    group to_PE1 {
      type external;
      local-address 8001::1;
      family inet6 {
        unicast;
      }
      export policy1;
      peer-as 100;
      neighbor 8001::2;
    }
  }
}
policy-options {
  policy-statement policy1 {
    term 1 {
      from {
        family inet6;
        route-filter 9001::1/128 exact;
      }
      then accept;
    }
    term 2 {
      then reject;
    }
  }
}

```

Once you move to PE1, your tasks become more complex. You must complete the IPv6 EBGP connection to CE1 and build the first part of the MPLS tunnel. You must set the `inet`, `inet6`, and `mpls` families on the core-facing interface, configure an `inet6` address for the CE-facing interface attached to CE1, and ensure the IPv4 loopback address is advertised in OSPF, since this is the MPLS LSP target for PE2. You must also add the `ipv6-tunneling` parameter in MPLS, include the `labeled-unicast` and `explicit-null` options at the `[edit protocols bgp family inet6]` hierarchy level, and create an external BGP group pointing to CE1 and an internal group pointing to PE2.

```

Router PE1 [edit]
interfaces {
  ge-6/1/0 {
    unit 0 {
      family inet6 {
        address 8001::2/126;
      }
    }
  }
  so-6/2/0 {
    unit 0 {
      family inet {
        address 100.255.2.1/24;
      }
      family inet6;
      family mpls;
    }
  }
  lo0 {
    unit 0 {
      family inet {
        address 10.255.255.16/32;
      }
    }
  }
}
routing-options {
  autonomous-system 100;
}
protocols {
  rsvp {
    interface so-6/2/0.0;
  }
  mpls {
    ipv6-tunneling;
    label-switched-path to_PE2 {
      to 10.255.255.15;
    }
    interface so-6/2/0.0;
  }
}

```

```

bgp {
  group to_PE2 {
    type internal;
    local-address 10.255.255.16;
    family inet6 {
      labeled-unicast {
        explicit-null;
      }
    }
    neighbor 10.255.255.15;
  }
  group to_CE1 {
    local-address 8001::2;
    family inet6 {
      unicast;
    }
    peer-as 200;
    neighbor 8001::1;
  }
}
ospf {
  traffic-engineering;
  area 0.0.0.0 {
    interface so-6/2/0.0;
    interface lo0.0 {
      passive;
    }
  }
}
}

```

On Router P, connect the MPLS tunnel between PE1 and PE2. Enable RSVP, MPLS, and IPv4 connectivity on the interfaces and ensure that IP connectivity is available through the routing protocol (in this case, OSPF).

```

Router P [edit]
interfaces {
  so-1/1/0 {
    unit 0 {
      family inet {
        address 100.255.2.2/24;
      }
      family mpls;
    }
  }
  so-4/0/0 {
    unit 0 {
      family inet {
        address 100.255.3.1/24;
      }
      family mpls;
    }
  }
}

```

```

lo0 {
  unit 0 {
    family inet {
      address 10.255.255.220/32;
    }
  }
}
}
routing-options {
  autonomous-system 100;
}
protocols {
  rsvp {
    interface so-1/1/0.0;
    interface so-4/0/0.0;
  }
  mpls {
    interface so-1/1/0.0;
    interface so-4/0/0.0;
  }
  ospf {
    traffic-engineering;
    area 0.0.0.0 {
      interface so-1/1/0.0;
      interface so-4/0/0.0;
      interface lo0.0 {
        passive;
      }
    }
  }
}
}

```

At PE2, you must complete a mirror image of the MPLS tunnel configuration started at PE1 and configure a RIPng connection to CE2. Set the `inet`, `inet6`, and `mpls` families on the core-facing interface, configure an `inet6` address for the CE facing interface attached to CE2, and ensure the IPv4 loopback address is advertised in OSPF, since this is the MPLS LSP target for PE1. You must also add the `ipv6-tunneling` parameter in MPLS and include the `labeled-unicast` and `explicit-null` options at the `[edit protocols bgp family inet6]` hierarchy level. Finally, create and apply policies that export BGP routes into RIPng and import RIPng routes to BGP.

```

Router PE2 [edit]
interfaces {
  so-0/0/0 {
    unit 0 {
      family inet {
        address 100.255.3.2/24;
      }
      family inet6;
      family mpls;
    }
  }
}

```

```

so-4/0/1 {
  unit 0 {
    family inet6 {
      address 8002::1/126;
    }
  }
}
lo0 {
  unit 0 {
    family inet {
      address 10.255.255.15/32;
    }
  }
}
}
routing-options {
  autonomous-system 100;
}
protocols {
  rsvp {
    interface so-0/0/0.0;
  }
  mpls {
    ipv6-tunneling;
    label-switched-path to_PE1 {
      to 10.255.255.16;
    }
    interface so-0/0/0.0;
  }
  bgp {
    group to_PE1 {
      type internal;
      local-address 10.255.255.15;
      family inet6 {
        labeled-unicast {
          explicit-null;
        }
      }
      export red-export;
      neighbor 10.255.255.16;
    }
  }
  ospf {
    traffic-engineering;
    area 0.0.0.0 {
      interface so-0/0/0.0;
      interface lo0.0 {
        passive;
      }
    }
  }
}
}

```

```

    ripng {
      group to_CE2 {
        export red-import;
        neighbor so-4/0/1.0;
      }
    }
  }
}
policy-options {
  policy-statement red-export {
    term 1 {
      from protocol ripng;
      then accept;
    }
    term 2 {
      then reject;
    }
  }
  policy-statement red-import {
    from protocol bgp;
    then accept;
  }
}

```

Finally, on CE2, configure IPv6 addresses on the SONET/SDH and loopback interfaces, enable RIPng, and create and apply a policy for RIPng that permits the IPv6 loopback address to be exported to PE2. Once these tasks are accomplished, your IPv6 connection to CE1 should be ready for use.

```

Router CE2 [edit]
interfaces {
  so-1/1/0 {
    unit 0 {
      family inet6 {
        address 8002::2/126;
      }
    }
  }
  lo0 {
    unit 0 {
      family inet6 {
        address 9001::5/128;
      }
    }
  }
}
routing-options {
  autonomous-system 300;
}
protocols {
  ripng {
    group to_PE2 {
      export policy1;
      neighbor so-1/1/0.0;
    }
  }
}

```

```

policy-options {
  policy-statement policy1 {
    term 1 {
      from {
        family inet6;
        route-filter 9001::5/128 exact;
      }
      then accept;
    }
    term 2 {
      then reject;
    }
  }
}

```

Checking Your Work

To verify that IPv6 traffic is being transported over the IPv4 MPLS tunnel, use the following commands:

- ping
- show bgp summary
- show route protocol
- show route advertising-protocol
- show route receive-protocol
- show route table
- show route table (inet6.0 | inet6.3)
- show interfaces terse

The following sections show the output of these commands used with the configuration example:

- Router CE1 Status on page 326
- Router PE1 Status on page 327
- Router PE2 Status on page 328
- Router CE2 Status on page 329

Router CE1 Status

```

user@CE1> show bgp summary
Groups: 1 Peers: 1 Down peers: 0
Table Tot Paths Act Paths Suppressed History Damp State Pending
inet6.0 1 1 0 0 0 0
Peer AS InPkt OutPkt OutQ Flaps Last Up/Dwn
State|#Active/Received/Damped...
8001::2 100 58 56 0 0 26:25 Estab1
inet6.0: 1/1/0

```

```

user@CE1> show route protocol bgp

```

```

inet.0: 13 destinations, 13 routes (12 active, 0 holddown, 1 hidden)

```

```

iso.0: 1 destinations, 1 routes (1 active, 0 holddown, 0 hidden)

```

```

inet6.0: 7 destinations, 7 routes (7 active, 0 holddown, 0 hidden)

```

```

+ = Active Route, - = Last Active, * = Both

```

```

9001::5/128 * [BGP/170] 00:04:18, localpref 100
AS path: 100 I
> to 8001::2 via ge-7/1/0.0

```

```

user@CE1> ping 9001::5 source 9001::1
PING6(56=40+8+8 bytes) 9001::1 --> 9001::5
16 bytes from 9001::5, icmp_seq=0 hlim=62 time=0.945 ms
16 bytes from 9001::5, icmp_seq=1 hlim=62 time=0.831 ms
^C
--- 9001::5 ping6 statistics ---
2 packets transmitted, 2 packets received, 0% packet loss
round-trip min/avg/max = 0.831/0.887/0.945 ms

```

Router PE1 Status

```

user@PE1> show bgp summary
Groups: 2 Peers: 2 Down peers: 0
Table Tot Paths Act Paths Suppressed History Damp State Pending
inet6.0 2 2 0 0 0 0
Peer AS InPkt OutPkt OutQ Flaps Last Up/Dwn
State|#Active/Received/Damped...
8001::1 200 56 61 0 0 27:18 Establ
inet6.0: 1/1/0
10.255.255.15 100 13 14 0 1 5:28 Establ
inet6.0: 1/1/0

```

```

user@PE1> show route advertising-protocol bgp 10.255.255.15 detail

```

```

inet6.0: 8 destinations, 8 routes (8 active, 0 holddown, 0 hidden)
9001::1/128 (1 entry, 1 announced)
  BGP group to_PE2 type Internal
  Route Label: 2
  Nexthop: Self
  Localpref: 100
  AS path: 200 I
  Communities:

```

```

user@PE1> show route 9001::5

```

```

inet6.0: 8 destinations, 8 routes (8 active, 0 holddown, 0 hidden)
+ = Active Route, - = Last Active, * = Both

9001::5/128      *[BGP/170] 00:05:48, MED 2, localpref 100, from 10.255.255.15
                  AS path: I
                  > via so-6/2/0.0, label-switched-path to_PE2

```

```

user@PE1> show route table inet6.0

```

```

inet6.0: 8 destinations, 8 routes (8 active, 0 holddown, 0 hidden)
+ = Active Route, - = Last Active, * = Both

8001::/126      *[Direct/0] 00:29:01
                  > via ge-6/1/0.0
8001::2/128     *[Local/0] 00:29:01
                  Local via ge-6/1/0.0
9001::1/128     *[BGP/170] 00:28:46, localpref 100
                  AS path: 200 I
                  > to 8001::1 via ge-6/1/0.0
9001::2/128     *[Direct/0] 00:29:01
                  > via lo0.0
9001::5/128     *[BGP/170] 00:06:56, MED 2, localpref 100, from 10.255.255.15
                  AS path: I
                  > via so-6/2/0.0, label-switched-path to_PE2
fe80::/64      *[Direct/0] 00:29:01
                  > via ge-6/1/0.0
fe80::280:42ff:fe10:d30c/128
                  *[Direct/0] 00:29:01
                  > via lo0.0
fe80::290:69ff:fe0f:1633/128
                  *[Local/0] 00:29:01
                  Local via ge-6/1/0.0

```

```
user@PE1> show route table inet6.3
```

```
inet6.3: 1 destinations, 1 routes (1 active, 0 holddown, 0 hidden)
+ = Active Route, - = Last Active, * = Both
```

```
::ffff:10.255.255.15/128 *[RSVP/7] 00:06:37, metric 2, metric2 0
> via so-6/2/0.0, label-switched-path to_PE2
```

Router PE2 Status

```
user@PE2> show bgp summary
```

```
Groups: 1 Peers: 1 Down peers: 0
```

Table	Tot Paths	Act Paths	Suppressed	History	Damp	State	Pending
inet6.0	1	1	0	0	0	0	0

Peer	AS	InPkt	OutPkt	OutQ	Flaps	Last Up/Dwn
10.255.255.16	100	18	20	0	0	8:06 Establ

```
State|#Active/Received/Damped...
inet6.0: 1/1/0
```

```
user@PE2> show interfaces terse so-4/0/1
```

Interface	Admin	Link	Proto	Local	Remote
so-4/0/1	up	up			
so-4/0/1.0	up	up	inet	100.1.4.1/24	
			inet6	8002::1/126	
				fe80::280:42ff:fe10:d312/64	

```
user@PE2> show route receive-protocol bgp 10.255.255.16 detail
```

```
inet.0: 18 destinations, 19 routes (17 active, 0 holddown, 1 hidden)
```

```
inet.3: 1 destinations, 1 routes (1 active, 0 holddown, 0 hidden)
```

```
iso.0: 1 destinations, 1 routes (1 active, 0 holddown, 0 hidden)
```

```
mpls.0: 3 destinations, 3 routes (3 active, 0 holddown, 0 hidden)
```

```
inet6.0: 8 destinations, 8 routes (8 active, 0 holddown, 0 hidden)
```

```
9001::1/128 (1 entry, 1 announced)
```

```
Route Label: 2
```

```
Nexthop: ::ffff:10.255.255.16
```

```
Localpref: 100
```

```
AS path: 200 I
```

```
inet6.3: 1 destinations, 1 routes (1 active, 0 holddown, 0 hidden)
```

```
user@PE2> show route advertising-protocol ripng fe80::280:42ff:fe10:d312 detail
```

```
inet6.0: 8 destinations, 8 routes (8 active, 0 holddown, 0 hidden)
```

```
9001::1/128 (1 entry, 1 announced)
```

```
*BGP Preference: 170/-101
```

```
Source: 10.255.255.16
```

```
Next hop: via so-0/0/0.0, weight 1, selected
```

```
Label-switched-path to_PE1
```

```
Label operation: Push 2, Push 100015(top)
```

```
Protocol next hop: ::ffff:10.255.255.16
```

```
Push 2
```

```
Indirect next hop: 8451440 50
```

```
State: <Active Int Ext>
```

```
Local AS: 100 Peer AS: 100
```

```
Age: 2:27 Metric2: 2
```

```
Task: BGP_100.10.255.255.16+179
```

```
Announcement bits (3): 0-KRT 1-RIPng 3-Resolve inet6.0
```

```
AS path: 200 I
```

```
Route Label: 2
```

Router CE2 Status

```

user@CE2> show ripng neighbor

```

Neighbor	State	Source Address	Dest Address	Send	Recv	In Met
so-1/1/0.0	Up	fe80::2a0:a5ff:fe12:34d9	ff02::9	yes	yes	1

```

user@CE2> show route protocol ripng

inet.0: 12 destinations, 12 routes (11 active, 0 holddown, 1 hidden)

iso.0: 1 destinations, 1 routes (1 active, 0 holddown, 0 hidden)

inet6.0: 7 destinations, 7 routes (7 active, 0 holddown, 0 hidden)
+ = Active Route, - = Last Active, * = Both

9001::1/128      *[RIPng/100] 00:04:10, metric 2, tag 0
                 > to fe80::280:42ff:fe10:d312 via so-1/1/0.0
ff02::9/128     *[RIPng/100] 02:42:33, metric 1
                 MultiRecv

```

For More Information

For additional information about connecting IPv6 islands with IPv4 MPLS, see the following:

- *JUNOS MPLS Applications Configuration Guide*
- *JUNOS Routing Protocols Configuration Guide*
- RFC 3032, *MPLS Label Stack Encoding*
- RFC 3107, *Carrying Label Information in BGP-4*
- RFC 3513, *IP Version 6 Addressing Architecture*
- Internet draft draft-ietf-ngtrans-bgp-tunnel-04.txt, *Connecting IPv6 Domains across IPv4 Clouds with BGP* (expires July 2002)

Revision History

- 13 June 2005—7.3R1 Release. Richard Hendricks.
- 5 April 2005—Added support for J-series Services Routers, 7.2R1 Release. Richard Hendricks.
- 2 February 2005—7.1R1 Release. Richard Hendricks.
- 6 October 2004—7.0R1 Release. Richard Hendricks.
- 6 July 2004—6.4R1 Release. Richard Hendricks.
- 5 April 2004—6.3R1 Release. Richard Hendricks.
- 22 December 2003—6.2R1 Release. Richard Hendricks.
- 22 September 2003—6.1R1 Release. Richard Hendricks.
- 30 June 2003—6.0R1 Release. Richard Hendricks.
- 2 April 2003—5.7R1 Release. Richard Hendricks.
- 27 December 2002—5.6R1 Release. Richard Hendricks.
- 30 September 2002—5.5R1 Release. Richard Hendricks.
- 19 July 2002—5.4R1 Release. Richard Hendricks.
- 6 May 2002—Initial document written. Richard Hendricks.