

## Chapter 23

# Layer 2 Circuits Example

The example presented in this chapter illustrates how you might configure a Layer 2 circuit with protect interfaces. Protect interfaces act as backups for their associated interfaces. The primary interface has priority over the protect interface and carries network traffic as long as it is functional. If the primary interface fails, the protect interface is activated. These interfaces can also share the same virtual path identifier (VPI) or virtual circuit identifier (VCI).

For more examples on how to configure Layer 2 circuits, see the *JUNOS Internet Software Feature Guide*.

Figure 49 shows the network topology used in this example.

**Figure 49: Layer 2 Circuits Using Protect Interfaces**

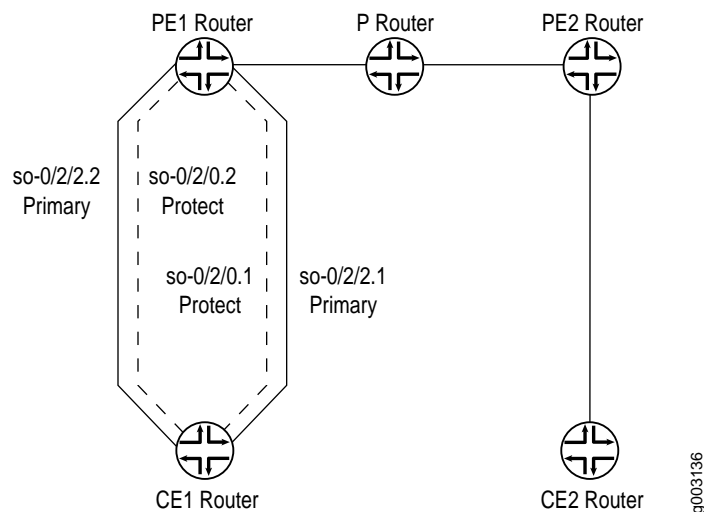

The following sections describe how to configure a Layer 2 circuit to use a protect interface:

Configure Router PE1 on page 454

Configure Router PE2 on page 456

Configure Router CE1 on page 457

Configure Router CE2 on page 458

## Configure Router PE1

---

Configure an interface for traffic to Router CE1 from Router PE1 at the [edit interfaces] hierarchy level:

```
[edit interfaces]
so-0/2/2 {
  description "Router CE1 so-0/2/2";
  no-keepalives;
  encapsulation frame-relay-ccc;
  unit 1 {
    encapsulation frame-relay-ccc;
    point-to-point;
    dlci 600;
  }
  unit 2 {
    encapsulation frame-relay-ccc;
    point-to-point;
    dlci 602;
  }
}
```

Configure an interface for traffic to Router CE1 from Router PE1 at the [edit interfaces] hierarchy level. Logical interface so-0/2/0.2 acts as the protect interface for so-0/2/2.2, and logical interface so-0/2/0.1 acts as the protect interface for so-0/2/2.1:

```
[edit interfaces]
so-0/2/0 {
  description "to Router CE1 so-0/3/0";
  no-keepalives;
  encapsulation frame-relay-ccc;
  unit 1 {
    encapsulation frame-relay-ccc;
    dlci 600;
  }
  unit 2 {
    encapsulation frame-relay-ccc;
    dlci 602;
  }
}
```

Configure an interface for traffic to Router PE2 from Router PE1 at the [edit interfaces] hierarchy level:

```
[edit interfaces]
so-0/2/1 {
  description "to Router PE2 so-1/0/1";
  unit 0 {
    family inet {
      address 100.100.40.22/32 {
        destination 100.100.40.23;
      }
    }
    family iso;
    family mpls;
  }
}
```

Configure an interface for traffic to Router PE2 from Router PE1 at the [edit interfaces] hierarchy level:

```
[edit interfaces]
so-0/2/3 {
  description "Router PE2 so-1/0/3";
  unit 0 {
    family inet;
    family iso;
    family mpls;
  }
  lo0 {
    unit 0 {
      family inet {
        address 127.0.0.1/32;
        address 10.100.40.200/32;
      }
      family iso {
        address 47.0005.80ff.f800.0000.0108.0001.1921.6800.4213.00;
      }
    }
  }
}
```

Configure the Layer 2 circuit by including the l2circuit statement at the [edit protocols] hierarchy level. The logical interfaces for the Layer 2 circuits and their corresponding protect interfaces are included here:

```
[edit protocols]
l2circuit {
  neighbor 10.100.40.210 {
    interface so-0/2/2.2 {
      protect-interface so-0/2/0.2;
      virtual-circuit-id 2;
      no-control-word;
    }
    interface so-0/2/2.1 {
      protect-interface so-0/2/0.1;
      virtual-circuit-id 1;
      no-control-word;
    }
  }
}
```

## Configure Router PE2

---

Configure an interface for traffic to Router CE2 from Router PE2:

```
[edit interfaces]
so-1/0/0 {
  description "to Router CE2 so-0/2/0";
  no-keepalives;
  encapsulation frame-relay-ccc;
  unit 1 {
    encapsulation frame-relay-ccc;
    point-to-point;
    dlcI 700;
  }
  unit 2 {
    encapsulation frame-relay-ccc;
    point-to-point;
    dlcI 702;
  }
}
```

Configure an interface for traffic to Router PE1 from Router PE2:

```
[edit interfaces]
so-1/0/1 {
  description "to Router PE1 so-0/2/1";
  unit 0 {
    family inet {
      address 100.100.40.23/32 {
        destination 100.100.40.22;
      }
    }
  }
  family iso;
  family mpls;
}
```

Configure an interface for traffic to Router PE1 from Router PE2:

```
[edit interfaces]
so-1/0/3 {
  description "to Router PE1 so-0/2/3";
  unit 0 {
    family inet;
    family iso;
    family mpls;
  }
}
lo0 {
  unit 0 {
    family inet {
      address 127.0.0.1/32;
      address 10.100.40.210/32;
    }
    family iso {
      address 47.0005.80ff.f800.0000.0108.0001.1921.6800.4216.00;
    }
  }
}
```

Configure the Layer 2 circuit at the [edit protocols] hierarchy level:

```
[edit protocols]
l2circuit {
  neighbor 10.100.40.200 {
    interface so-1/0/0.1 {
      virtual-circuit-id 1;
      no-control-word;
    }
    interface so-1/0/0.2 {
      virtual-circuit-id 2;
      no-control-word;
    }
  }
}
```

## Configure Router CE1

---

Configure an interface for traffic to Router PE1 from Router CE1:

```
[edit interfaces]
so-0/3/0 {
  description "to Router PE1 so-0/2/0";
  no-keepalives;
  encapsulation frame-relay;
  unit 1 {
    dlcI 601;
    family inet {
      address 12.12.12.1/24;
    }
  }
}
```

Configure an interface for traffic to Router PE1 from Router CE1:

```
[edit interfaces]
so-0/3/1 {
  description "Router PE1 so-0/2/2";
  no-keepalives;
  encapsulation frame-relay;
  unit 0 {
    dlcI 600;
    family inet {
      address 10.10.10.1/24;
      address 11.1.1.1/24;
    }
    family iso;
    family mpls;
  }
  unit 2 {
    dlcI 602;
    family inet {
      address 13.13.13.1/24;
    }
  }
}
```

## Configure Router CE2

---

Configure an interface for traffic to Router PE2 from Router CE2:

```
[edit interfaces]
so-0/2/0 {
  description "to Router PE2 so-1/0/0";
  no-keepalives;
  encapsulation frame-relay;
  unit 1 {
    dlcI 700;
    family inet {
      address 10.10.10.2/24;
      address 11.1.1.2/24;
      address 12.12.12.2/24;
    }
  }
  unit 2 {
    dlcI 702;
    family inet {
      address 13.13.13.2/24;
    }
  }
}
```