

Chapter 6

Multiple Instances for Label Distribution Protocol

Previous versions of JUNOS software support multiple VPN Routing and Forwarding (VRF) instances of Border Gateway Protocol (BGP), Intermediate System-to-Intermediate System (IS-IS), Open Shortest Path First (OSPF), Protocol Independent Multicast (PIM) and Routing Information Protocol (RIP). JUNOS 5.4 adds support for multiple instances of Label Distribution Protocol (LDP).

This support allows LDP to be used to advertise labels in a carrier-of-carriers scenario from a core provider edge (PE) router to a customer carrier edge (CE) router. This is especially useful when the carrier customer is a basic Internet Service Provider (ISP) and wants to restrict full Internet routes to its PE routers. By using LDP instead of BGP, the carrier customer shields its other internal routers from the Internet at large. Multiple-instance LDP is also useful when a carrier customer wants to provide Layer 2 VPN or Layer 3 VPN services to its customers.

Using multiple-instance LDP lets you circumvent one of the requirements of RFC 3107: the need to run full-mesh internal BGP (IBGP) within the carrier customer's autonomous system (AS). When you use multiple-instance LDP, full-mesh IBGP is unnecessary.

This feature guide covers these topics:

Overview on page 203

System Requirements on page 204

Terms and Acronyms on page 205

Configure Multiple-Instance LDP on page 205

Example: Multiple-Instance LDP Configuration on page 208

Check Your Work on page 226

For More Information on page 242

Revision History on page 242

Overview

In Figure 28, the customer carrier in AS 21 can configure one instance of LDP for all routers in AS 21 instead of using full-mesh IBGP.

Figure 28: Carrier-of-Carriers Example

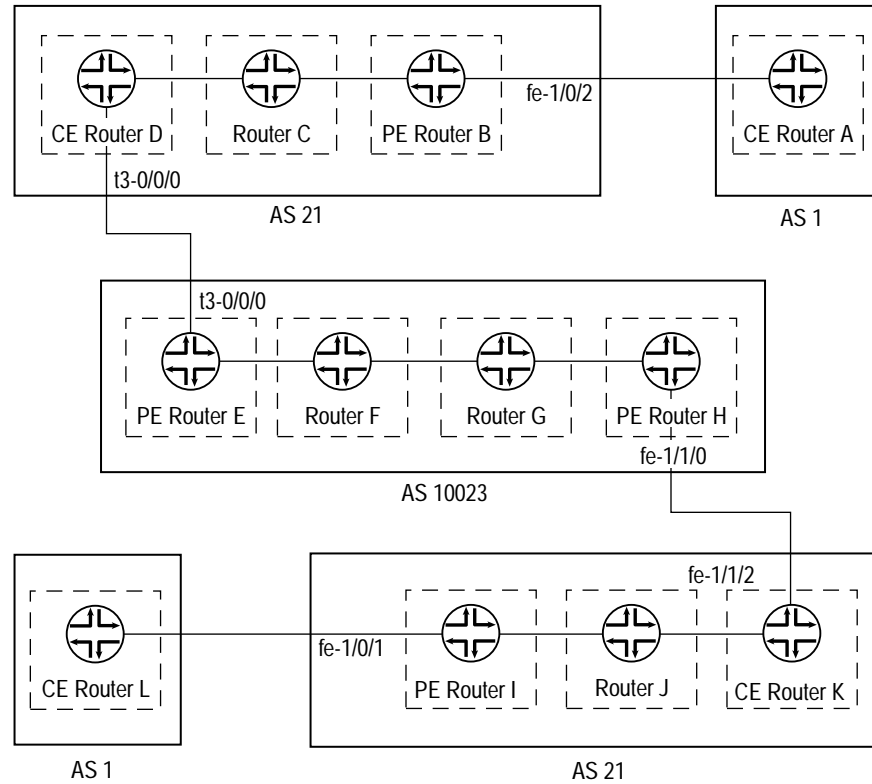

1729

In general, if there are a limited number of customer carrier sites and few internal routes in the customer carrier AS, it is simpler and quicker to use LDP than to configure a full IBGP mesh.

An instance of LDP operates essentially in the same way as a master instance. Each instance of LDP must be enabled on all the desired interfaces and a separate set of LDP data structures are maintained for each instance. Instance information includes a set of LDP interfaces, neighbors, sessions, and databases.

For more information about carrier-of-carriers VPNs, see the *JUNOS Internet Software VPNs Configuration Guide*.

For more information about LDP, see the *JUNOS Internet Software MPLS Applications Configuration Guide*.

System Requirements

To implement the multiple-instance LDP feature, your system must meet these minimum requirements:

- JUNOS Release 5.4 or later

- Two Juniper Networks M-series or T-series routing platforms for basic multiple-instance LDP; and a minimum of four Juniper Networks routing platforms to act as PE routers in a carrier-of-carriers network.

Terms and Acronyms

carrier-of-carriers VPN—A VPN that transports data traffic between two or more telecommunications carrier sites across a core provider network. The core provider becomes a carrier for the customer carrier, which, in turn, provides Internet or VPN services to end customers. For more information about carrier-of-carriers VPNs, see the *JUNOS Internet Software VPNs Configuration Guide*.

Label Distribution Protocol (LDP)—A protocol used to distribute labels in an MPLS-enabled network. For more information about LDP, see the *JUNOS Internet Software MPLS Applications Configuration Guide*.

VPN Routing and Forwarding (VRF) instance—A unique routing table created to maintain VPN routing and forwarding information. One routing table is created per instance, which keeps prefix information and data private from other instances. For more information about VRF instances, see the *JUNOS Internet Software VPNs Configuration Guide*.

Configure Multiple-Instance LDP

To configure multiple instances of LDP, you must perform the following tasks:

Configure a Master LDP Instance on page 206

Configure a VRF-Based LDP Instance on page 207

To view examples of Layer 2 TCC switching, see the following sections:

Example: Multiple-Instance LDP Configuration on page 208

Check Your Work on page 226

Configure a Master LDP Instance

The master LDP instance is configured at the [edit protocols] hierarchy level.

```
[edit]
protocols {
  ldp {
    apply-groups group-name;
    deaggregate | no-deaggregate;
    egress-policy policy-name;
    explicit-null;
    export policy-name;
    import policy-name;
    interface interface-name {
      disable;
      hello-interval seconds;
      hold-time seconds;
      deaggregate | no-deaggregate;
      transport-address (interface | loopback);
    }
    keepalive-interval seconds;
    keepalive-timeout seconds;
    no-forwarding;
    preference preference;
    traceoptions {
      file filename <replace> <size size> <files number> <no-stamp>
        <(world-readable | no-world-readable)>;
      flag flag <flag-modifier> <disable>;
    }
    track-igp-metric;
    traffic-statistics {
      file;
      interval;
    }
    transport-address (interface | loopback);
  }
}
```

Configure a VRF-Based LDP Instance

You can configure a specific instance of LDP by using the `ldp` statement at the `[edit routing-instances routing-instance-name protocols]` hierarchy level. This creates an instance of LDP for the particular VRF routing instance. You must specify all the required VRF statements and apply export and import policies to your LDP instance for the configuration to commit properly.

```
[edit]
routing-instances {
  routing-instance-name {
    instance-type vrf;
    interface interface-name;
    route-distinguisher route-distinguisher;
    vrf-import import-policy-name;
    vrf-export export-policy-name;
    protocols {
      ldp {
        interface all;
      }
    }
  }
}
```

Most of the LDP hierarchy available in a master instance is also available for specific instances of LDP. However, the `no-forwarding` option does not work in a VRF-based instance of LDP.

For more information about proper configuration of VRF instances, see the *JUNOS Internet Software VPNs Configuration Guide*. For the proper syntax related to policies, see the *JUNOS Internet Software Policy Framework Configuration Guide*.

Example: Multiple-Instance LDP Configuration

Figure 29: Multiple-Instance LDP Topology Diagram

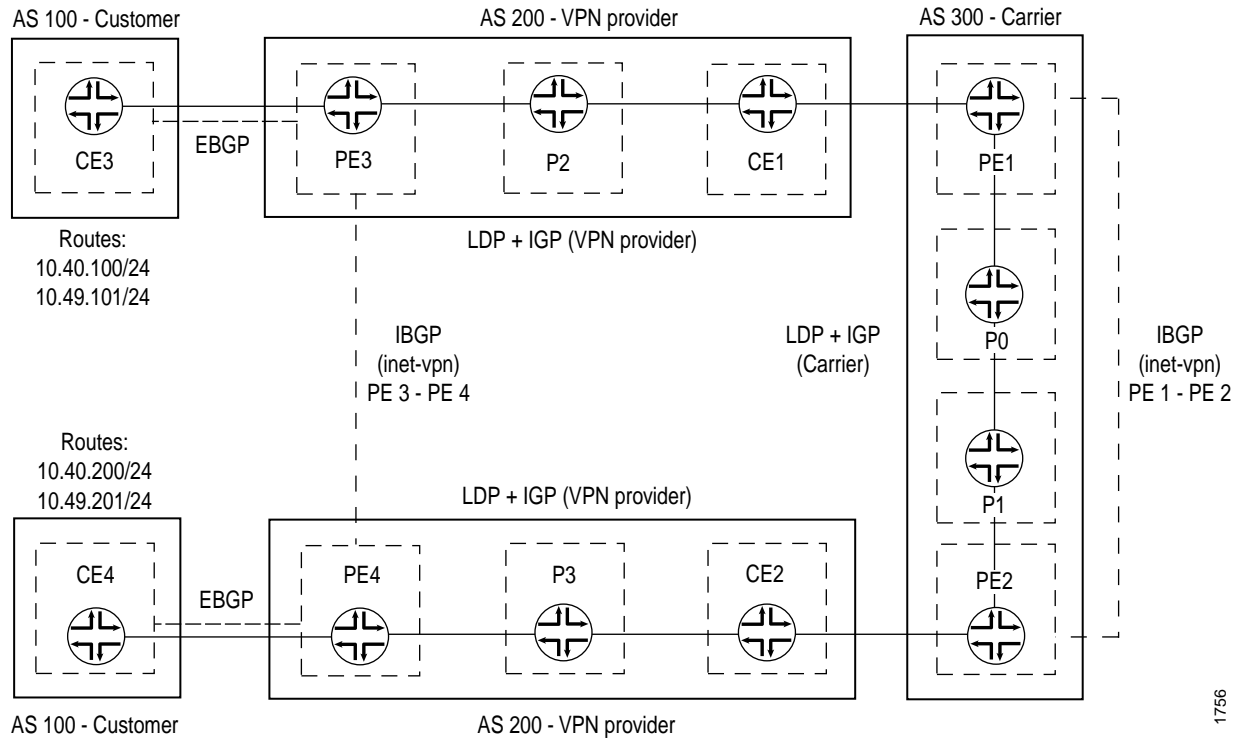

Figure 29 shows an example of a carrier-of-carriers network. CE3 and CE4 are end customer CE routers residing in AS 100. The VPN provider in AS 200 has three types of routers: PE3 and PE4 are PE routers that connect to the end customer, CE1 and CE2 act as the intermediate carrier CE routers, and P2 and P3 are internal transit routers. PE1 and PE2 in AS 300 are PE routers servicing the intermediate VPN provider, and P0 and P1 are transit routers for the top tier carrier.

To make this configuration work, you must complete three major tasks:

1. Configure external BGP between the VPN customer CE and the VPN provider PE.
2. Configure internal BGP using the VPN family between both pairs of PE routers (one IBGP connection between PE1 and PE2 and a second IBGP connection between PE3 and PE 4).
3. Establish LDP and Interior Gateway Protocol (IGP) connections on all remaining links. This example uses OSPF as the IGP, but you can use the IGP of your choice.

Information supporting this carrier-of-carriers multiple-instance LDP example is summarized in Table 23 and Table 24 on page 209.

Table 23: Multiple-Instance LDP Example—Routing Protocol Summary

Connection	Protocols
CE3 - PE3	EBGP family inet
PE3 - P2 - CE1	OSPF and LDP
CE1 - PE1	OSPF and LDP
PE1 - P0 - P1 - PE2	OSPF and LDP
PE1 - PE2	IBGP family inet-vpn
PE2 - CE2	OSPF and LDP
CE2 - P3 - PE4	OSPF and LDP
PE4 - CE4	EBGP family inet
PE3 - PE4	IBGP family inet-vpn

Table 24: Multiple-Instance LDP Example—Loopback Addresses

Router	Loopback Address
PE1	10.255.255.171
PE2	10.255.255.172
P0	10.255.255.173
P1	10.255.255.174
P2	10.255.255.175
P3	10.255.255.176
PE3	10.255.255.177
PE4	10.255.255.178
CE1	10.255.255.179
CE2	10.255.255.180
CE3	10.255.255.181 10.49.100.1
CE4	10.255.255.182 10.49.200.1

Your configuration tasks start at CE3 and move router-by-router through the first part of the VPN provider network, into the carrier AS, through the second VPN provider cluster of AS 200, and end at the second VPN customer Router CE4.

Since CE3 is the first customer router, configure EBGP between CE3 and the connected VPN provider Router PE3. You must also advertise your loopback address into BGP with a routing policy to allow IP reachability with CE4.

```

CE3 [edit]
interfaces {
  so-1/2/0 {
    description "to pe3 so-1/2/0";
    unit 0 {
      family inet {
        address 192.255.198.14/30;
      }
    }
  }
  lo0 {
    unit 0 {
      family inet {
        address 10.255.255.181/32;
        address 10.49.100.1/32;
      }
    }
  }
}
routing-options {
  static {
    route 10.49.100.0/24 reject;
    route 10.49.101.0/24 reject;
  }
  autonomous-system 100;
}
protocols {
  bgp {
    group provider {
      type external;
      export static-to-bgp;
      peer-as 200;
      neighbor 192.255.198.13;
    }
  }
}
policy-options {
  policy-statement static-to-bgp {
    term 1 {
      from {
        protocol static;
        route-filter 10.49.100.0/24 exact;
        route-filter 10.49.101.0/24 exact;
      }
      then accept;
    }
    term 2 {
      from protocol direct;
      then accept;
    }
    term 3 {
      then reject;
    }
  }
}

```

On PE3, the configuration tasks are more involved. You need to complete the EBGp connection to CE3 in a VRF instance, enable MPLS and LDP on the interface pointing toward the VPN provider CE1 router, and configure a master instance of IBGP to reach PE4 at the far edge of AS 200.

Finally, set up an outbound VRF policy that places all BGP traffic and directly connected interfaces into a BGP community and an inbound VRF policy that accepts similar BGP community traffic from PE4.

```

PE3 [edit]
interfaces {
  so-1/2/0 {
    unit 0 {
      family inet {
        address 192.255.198.13/30;
      }
      family mpls;
    }
  }
  so-1/2/1 {
    description "to p2 so-1/2/1";
    unit 0 {
      family inet {
        address 192.255.198.9/30;
      }
      family mpls;
    }
  }
  lo0 {
    unit 0 {
      family inet {
        address 10.255.255.177/32;
      }
    }
  }
}
routing-options {
  autonomous-system 200;
}
protocols {
  mpls {
    interface so-1/2/0.0;
  }
  bgp {
    group internal {
      type internal;
      local-address 10.255.255.177;
      peer-as 200;
      neighbor 10.255.255.178 {
        family inet-vpn {
          unicast;
        }
      }
    }
  }
  ospf {
    area 0.0.0.0 {
      interface so-1/2/1.0;
      interface lo0.0 {
        passive;
      }
    }
  }
}

```

```

ldp {
  interface so-1/2/1.0;
}
}
policy-options {
  policy-statement vpn-customer-import {
    term 1 {
      from {
        protocol bgp;
        community vpn-customer-comm;
      }
      then accept;
    }
    term 2 {
      then reject;
    }
  }
  policy-statement vpn-customer-export {
    term 1 {
      from protocol [ bgp direct ];
      then {
        community add vpn-customer-comm;
        accept;
      }
    }
    term 2 {
      then reject;
    }
  }
  community vpn-customer-comm members target:200:100;
}
routing-instances {
  vpn-customer {
    instance-type vrf;
    interface so-1/2/0.0;
    route-distinguisher 10.255.255.177:1;
    vrf-import vpn-customer-import;
    vrf-export vpn-customer-export;
    protocols {
      bgp {
        group customer {
          type external;
          peer-as 100;
          as-override;
          neighbor 192.255.198.14;
        }
      }
    }
  }
}
}

```

On P2, enable LDP and the IGP used for transporting labels (in this case, OSPF). You will repeat these tasks on all transit core routers, both in the VPN provider network and the core carrier network.

```

P2 [edit]
interfaces {
  so-1/2/0 {
    description "to ce1 so-1/2/0";
    unit 0 {
      family inet {
        address 192.255.198.2/30;
      }
      family mpls;
    }
  }
  so-1/2/1 {
    description "to pe3 so-1/2/1";
    unit 0 {
      family inet {
        address 192.255.198.10/30;
      }
      family mpls;
    }
  }
  lo0 {
    unit 0 {
      family inet {
        address 10.255.255.175/32;
      }
    }
  }
}
routing-options {
  autonomous-system 200;
}
protocols {
  ospf {
    area 0.0.0.0 {
      interface lo0.0 {
        passive;
      }
      interface so-1/2/0.0;
      interface so-1/2/1.0;
    }
  }
  ldp {
    interface so-1/2/0.0;
    interface so-1/2/1.0;
  }
}

```

For Router CE1, configure LDP and OSPF in the same manner that you configured the P2 router.

```

CE1 [edit]
interfaces {
  t3-0/1/0 {
    description "to pe1 t3-0/2/1";
    unit 0 {
      family inet {
        address 192.255.197.18/30;
      }
      family mpls;
    }
  }
  so-1/2/0 {
    description "to p2 so-1/2/0";
    unit 0 {
      family inet {
        address 192.255.198.1/30;
      }
      family mpls;
    }
  }
  lo0 {
    unit 0 {
      family inet {
        address 10.255.255.179/32;
      }
    }
  }
}
routing-options {
  autonomous-system 200;
}
protocols {
  ospf {
    area 0.0.0.0 {
      interface so-1/2/0.0;
      interface lo0.0 {
        passive;
      }
      interface t3-0/1/0.0;
    }
  }
  ldp {
    interface t3-0/1/0.0;
    interface so-1/2/0.0;
  }
}

```

On core carrier Router PE1, configure a master instance for OSPF, LDP, MPLS, and IBGP (with the family inet-vpn option) to connect the router to neighbor PE2. Next, implement multiple-instance LDP by establishing a secondary instance. Enable LDP and OSPF in this instance for PE1 to communicate with CE1. MPLS is not required in the secondary instance.

Finally, set up an outbound VRF policy that places all LDP traffic coming from CE1 into a BGP community, an export policy that sends this community traffic to PE2, and an inbound VRF policy that accepts similar BGP community traffic from PE2. This step tunnels the VPN provider's LDP traffic into the carrier's BGP session.

```

PE1 [edit]
interfaces {
  so-0/0/0 {
    description "to p0 so-0/1/0";
    unit 0 {
      family inet {
        address 192.255.197.21/30;
      }
      family mpls;
    }
  }
  t3-0/2/1 {
    description "to ce1 t3-0/1/0";
    unit 0 {
      family inet {
        address 192.255.197.17/30;
      }
      family mpls;
    }
  }
  lo0 {
    unit 0 {
      family inet {
        address 10.255.255.171/32;
      }
    }
  }
}
routing-options {
  autonomous-system 300;
}
protocols {
  mpls {
    interface t3-0/2/1.0;
  }
  bgp {
    group pe {
      type internal;
      local-address 10.255.255.171;
      family inet-vpn {
        unicast;
      }
      peer-as 300;
      neighbor 10.255.255.172;
    }
  }
  ospf {
    area 0.0.0.0 {
      interface lo0.0 {
        passive;
      }
      interface so-0/0/0.0;
    }
  }
  ldp {
    interface so-0/0/0.0;
  }
}

```

```

policy-options {
  policy-statement vpn-provider-import {
    term 1 {
      from {
        protocol bgp;
        community vpn-provider-comm;
      }
      then accept;
    }
    term 2 {
      then reject;
    }
  }
  policy-statement vpn-provider-export {
    term 1 {
      from protocol ldp;
      then {
        community add vpn-provider-comm;
        accept;
      }
    }
    term 2 {
      then reject;
    }
  }
  policy-statement bgp-routes-to-export {
    term 1 {
      from {
        protocol bgp;
        community vpn-provider-comm;
      }
      then accept;
    }
    term 2 {
      then reject;
    }
  }
  community vpn-provider-comm members target:300:200;
}
routing-instances {
  vpn-provider {
    instance-type vrf;
    interface t3-0/2/1.0;
    route-distinguisher 10.255.255.171:1;
    vrf-import vpn-provider-import;
    vrf-export vpn-provider-export;
    protocols {
      ospf {
        export bgp-routes-to-export;
        area 0.0.0.0 {
          interface t3-0/2/1.0;
        }
      }
      ldp {
        egress-policy bgp-routes-to-export;
        interface t3-0/2/1.0;
      }
    }
  }
}
}

```

On P0, enable LDP and OSPF in the same manner that you configured these protocols on P2. You will repeat these tasks on routers P1 and P3.

```

P0 [edit]
interfaces {
  so-0/1/0 {
    description "to pe1 so-0/0/0";
    unit 0 {
      family inet {
        address 192.255.197.22/30;
      }
      family mpls;
    }
  }
  so-1/0/0 {
    description "to p1 so-1/0/0";
    unit 0 {
      family inet {
        address 192.255.197.85/30;
      }
      family mpls;
    }
  }
  lo0 {
    unit 0 {
      family inet {
        address 10.255.255.173/32;
      }
    }
  }
}
routing-options {
  autonomous-system 300;
}
protocols {
  ospf {
    area 0.0.0.0 {
      interface so-0/1/0.0;
      interface so-1/0/0.0;
      interface lo0.0 {
        passive;
      }
    }
  }
  ldp {
    interface so-0/1/0.0;
    interface so-1/0/0.0;
  }
}

```

On P1, enable LDP and the IGP used for transporting labels (OSPF in this case).

```

P1 [edit]
interfaces {
  so-0/0/0 {
    description "to pe2 so-0/2/0";
    unit 0 {
      family inet {
        address 192.255.197.74/30;
      }
      family mpls;
    }
  }
  so-1/0/0 {
    description "to p0 so-1/0/0";
    unit 0 {
      family inet {
        address 192.255.197.86/30;
      }
      family mpls;
    }
  }
  lo0 {
    unit 0 {
      family inet {
        address 10.255.255.174/32;
      }
    }
  }
}
routing-options {
  autonomous-system 300;
}
protocols {
  ospf {
    area 0.0.0.0 {
      interface so-0/0/0.0;
      interface so-1/0/0.0;
      interface lo0.0 {
        passive;
      }
    }
  }
  ldp {
    interface so-0/0/0.0;
    interface so-1/0/0.0;
  }
}

```

Core carrier Router PE2 is a mirror image of PE1. First, configure a master instance for OSPF, LDP, MPLS, and IBGP (with the family inet-vpn option) to connect PE2 to neighbor PE1. Next, implement multiple-instance LDP by establishing a secondary instance. Enable LDP and OSPF in this instance for PE2 to communicate with CE2. MPLS is not required in the secondary instance.

Finally, set up an outbound VRF policy that places all LDP traffic coming from CE2 into a BGP community, an export policy that sends this community traffic to PE1, and an inbound VRF policy that accepts similar BGP community traffic from PE1. This step tunnels the VPN provider's LDP traffic into the carrier's BGP session.

```

PE2 [edit]
interfaces {
  so-0/2/0 {
    description "to p1 so-0/0/0";
    unit 0 {
      family inet {
        address 192.255.197.73/30;
      }
      family mpls;
    }
  }
  t1-3/0/0 {
    description "to ce2 t1-0/0/0";
    unit 0 {
      family inet {
        address 192.255.197.37/30;
      }
      family mpls;
    }
  }
  lo0 {
    unit 0 {
      family inet {
        address 10.255.255.172/32;
      }
    }
  }
}
routing-options {
  autonomous-system 300;
}
protocols {
  mpls {
    interface t1-3/0/0.0;
  }
  bgp {
    group pe {
      type internal;
      local-address 10.255.255.172;
      family inet-vpn {
        unicast;
      }
      peer-as 300;
      neighbor 10.255.255.171;
    }
  }
  ospf {
    area 0.0.0.0 {
      interface so-0/2/0.0;
      interface lo0.0 {
        passive;
      }
    }
  }
  ldp {
    interface so-0/2/0.0;
  }
}

```

```

policy-options {
  policy-statement vpn-provider-import {
    term 1 {
      from {
        protocol bgp;
        community vpn-provider-comm;
      }
      then accept;
    }
    term 2 {
      then reject;
    }
  }
  policy-statement vpn-provider-export {
    term 1 {
      from protocol ldp;
      then {
        community add vpn-provider-comm;
        accept;
      }
    }
    term 2 {
      then reject;
    }
  }
  policy-statement bgp-routes-to-export {
    term 1 {
      from {
        protocol bgp;
        community vpn-provider-comm;
      }
      then accept;
    }
    term 2 {
      then reject;
    }
  }
  community vpn-provider-comm members target:300:200;
}

```

```

routing-instances {
  vpn-provider {
    instance-type vrf;
    interface t1-3/0/0.0;
    route-distinguisher 10.255.255.172:1;
    vrf-import vpn-provider-import;
    vrf-export vpn-provider-export;
    protocols {
      ospf {
        export bgp-routes-to-export;
        area 0.0.0.0 {
          interface t1-3/0/0.0;
        }
      }
      ldp {
        egress-policy bgp-routes-to-export;
        interface t1-3/0/0.0;
      }
    }
  }
}

```

For Router CE2, configure LDP and OSPF as you did on CE1 and the transit P routers.

```

CE2 [edit]
interfaces {
  t1-0/0/0 {
    description "to pe2 t1-3/0/0";
    unit 0 {
      family inet {
        address 192.255.197.38/30;
      }
      family mpls;
    }
  }
  t3-0/3/3 {
    description "to p3 t3-0/0/3";
    unit 0 {
      family inet {
        address 192.255.198.26/30;
      }
      family mpls;
    }
  }
  lo0 {
    unit 0 {
      family inet {
        address 10.255.255.180/32;
      }
    }
  }
}
routing-options {
  autonomous-system 200;
}

```

```

protocols {
  ospf {
    area 0.0.0.0 {
      interface t1-0/0/0.0;
      interface t3-0/3/3.0;
      interface lo0.0 {
        passive;
      }
    }
  }
  ldp {
    interface t1-0/0/0.0;
    interface t3-0/3/3.0;
  }
}

```

Since P3 is another core provider router, enable LDP and OSPF on all transit interfaces.

```

P3 [edit]
interfaces {
  t3-0/0/3 {
    description "to ce2 t3-0/3/3";
    unit 0 {
      family inet {
        address 192.255.198.25/30;
      }
      family mpls;
    }
  }
  t1-0/1/1 {
    description "to pe4 t1-0/1/1";
    unit 0 {
      family inet {
        address 192.255.198.37/30;
      }
      family mpls;
    }
  }
  lo0 {
    unit 0 {
      family inet {
        address 10.255.255.176/32;
      }
    }
  }
}
routing-options {
  autonomous-system 200;
}

```

```

protocols {
  ospf {
    area 0.0.0.0 {
      interface t3-0/0/3.0;
      interface t1-0/1/1.0;
      interface lo0.0 {
        passive;
      }
    }
  }
  ldp {
    interface t3-0/0/3.0;
    interface t1-0/1/1.0;
  }
}

```

On PE4, complete the IBGP connection initiated on PE3 to connect the edge routers in AS 200. Also, enable LDP and MPLS on the t1-0/0/1 interface pointing toward the VPN provider CE2 router and establish an EBGP connection to CE4 through use of a VRF instance.

Finally, set up an outbound VRF policy that places all BGP traffic and directly connected interfaces into a BGP community and an inbound VRF policy that accepts similar BGP community traffic from PE3.

```

PE4 [edit]
interfaces {
  t3-0/0/3 {
    description to ce4 t3-0/0/3";
    unit 0 {
      family inet {
        address 192.255.198.21/30;
      }
      family mpls;
    }
  }
  t1-0/1/1 {
    unit 0 {
      family inet {
        address 192.255.198.38/30;
      }
      family mpls;
    }
  }
  lo0 {
    unit 0 {
      family inet {
        address 10.255.255.178/32;
      }
    }
  }
}
routing-options {
  autonomous-system 200;
}

```

```

protocols {
  mpls {
    interface t3-0/0/3.0;
  }
  bgp {
    group internal {
      type internal;
      local-address 10.255.255.178;
      peer-as 200;
      neighbor 10.255.255.177 {
        family inet-vpn {
          unicast;
        }
      }
    }
  }
  ospf {
    area 0.0.0.0 {
      interface t1-0/1/1.0;
      interface lo0.0 {
        passive;
      }
    }
  }
  ldp {
    interface t1-0/1/1.0;
  }
}
policy-options {
  policy-statement vpn-customer-import {
    term 1 {
      from {
        protocol bgp;
        community vpn-customer-comm;
      }
      then accept;
    }
    term 2 {
      then reject;
    }
  }
  policy-statement vpn-customer-export {
    term 1 {
      from protocol [ bgp direct ];
      then {
        community add vpn-customer-comm;
        accept;
      }
    }
    term 2 {
      then reject;
    }
  }
  community vpn-customer-comm members target:200:100;
}

```

```

routing-instances {
  vpn-customer {
    instance-type vrf;
    interface t3-0/0/3.0;
    route-distinguisher 10.255.255.178:1;
    vrf-import vpn-customer-import;
    vrf-export vpn-customer-export;
    protocols {
      bgp {
        group customer {
          type external;
          peer-as 100;
          as-override;
          neighbor 192.255.198.22;
        }
      }
    }
  }
}

```

CE4 is the destination VPN customer router. Configure EBGP between CE4 and the connected VPN provider Router PE4 to complete the configuration. Remember to advertise the loopback address into BGP by using a routing policy to allow IP reachability with CE3.

```

CE4 [edit]
interfaces {
  t3-0/0/3 {
    description "to pe4 t3-0/0/3";
    unit 0 {
      family inet {
        address 192.255.198.22/30;
      }
    }
  }
  lo0 {
    unit 0 {
      family inet {
        address 10.255.255.182/32;
        address 10.49.200.1/32;
      }
    }
  }
}
routing-options {
  static {
    route 10.49.200.0/24 reject;
    route 10.49.201.0/24 reject;
  }
  autonomous-system 100;
}
protocols {
    bgp {
    group provider {
      type external;
      export static-to-bgp;
      peer-as 200;
      neighbor 192.255.198.21;
    }
  }
}

```

```

policy-options {
  policy-statement static-to-bgp {
    term 1 {
      from {
        protocol static;
        route-filter 10.49.200.0/24 exact;
        route-filter 10.49.201.0/24 exact;
      }
      then accept;
    }
    term 2 {
      from protocol direct;
      then accept;
    }
    term 3 {
      then reject;
    }
  }
}

```

Check Your Work

To verify the proper operation of your multiple-instance LDP configuration, use the following commands:

```

show ldp database
show ldp interface
show ldp neighbor
show ldp path
show ldp route
show ldp session
show ldp statistics

```

The display output for these commands is the same as in previous JUNOS software releases, except for one difference. An instance name can now be used as an argument.

If you include an instance name with these commands, you display information for the specified LDP instance. For example, the command `show ldp neighbor instance crockett` shows all the LDP neighbors for a VRF instance named `crockett`. Conversely, `show ldp neighbor` without an instance name displays the LDP neighbors associated with the master instance.

The following sections show the output of these commands used with the configuration example:

CE3 Status on page 227

PE3 Status on page 227

CE1 Status on page 230

PE1 Status on page 231

PE2 Status on page 234

CE2 Status on page 236

PE4 Status on page 238

CE4 Status on page 241

CE3 Status

```
user@CE3> show bgp summary
Groups: 1 Peers: 1 Down peers: 0
Table          Tot Paths  Act Paths Suppressed  History  Damp State   Pending
inet.0         10         5          0           0        0      0         0
Peer          AS          InPkt      OutPkt      OutQ     Flaps Last Up/Dwn
State|#Active/Received/Damped...
192.255.198.13 200        440        433         0         0      3:34:34 5/10/0
0/0/0
```

```
user@CE3> show route protocol bgp
```

```
inet.0: 23 destinations, 28 routes (22 active, 0 holddown, 6 hidden)
+ = Active Route, - = Last Active, * = Both
```

```
10.49.200.0/24  *[BGP/170] 00:19:20, localpref 100
                  AS path: 200 200 I
                  > to 192.255.198.13 via so-1/2/0.0
10.49.200.1/32  *[BGP/170] 00:19:20, localpref 100
                  AS path: 200 200 I
                  > to 192.255.198.13 via so-1/2/0.0
10.49.201.0/24  *[BGP/170] 00:19:20, localpref 100
                  AS path: 200 200 I
                  > to 192.255.198.13 via so-1/2/0.0
10.255.255.182/32 *[BGP/170] 00:19:20, localpref 100
                  AS path: 200 200 I
                  > to 192.255.198.13 via so-1/2/0.0
192.255.198.20/30 *[BGP/170] 00:19:20, localpref 100
                  AS path: 200 I
                  > to 192.255.198.13 via so-1/2/0.0
```

PE3 Status

```
user@PE3> show bgp summary
Groups: 2 Peers: 2 Down peers: 0
Table          Tot Paths  Act Paths Suppressed  History  Damp State   Pending
bgp.l3vpn.0    6          6          0           0        0      0         0
Peer          AS          InPkt      OutPkt      OutQ     Flaps Last Up/Dwn
State|#Active/Received/Damped...
192.255.198.14 100        432        441         0         0      3:34:55 Establ
  vpn-customer.inet.0: 5/6/0
10.255.255.178 200        62         63         0         2      27:23 Establ
  bgp.l3vpn.0: 6/6/0
  vpn-customer.inet.0: 5/6/0
```

```

user@PE3> show route protocol bgp

inet.0: 19 destinations, 20 routes (18 active, 0 holddown, 1 hidden)

inet.3: 5 destinations, 5 routes (5 active, 0 holddown, 0 hidden)

vpn-customer.inet.0: 12 destinations, 14 routes (12 active, 0 holddown, 0
hidden)
+ = Active Route, - = Last Active, * = Both

10.49.100.0/24    *[BGP/170] 03:34:59, MED 0, localpref 100
                 AS path: 100 I
                 > to 192.255.198.14 via so-1/2/0.0
10.49.100.1/32  *[BGP/170] 03:34:59, localpref 100
                 AS path: 100 I
                 > to 192.255.198.14 via so-1/2/0.0
10.49.101.0/24  *[BGP/170] 03:34:59, MED 0, localpref 100
                 AS path: 100 I
                 > to 192.255.198.14 via so-1/2/0.0
10.49.200.0/24  *[BGP/170] 00:26:39, MED 0, localpref 100, from
10.255.255.178
                 AS path: 100 I
                 > via so-1/2/1.0, Push 100019, Push 100008(top)
10.49.200.1/32  *[BGP/170] 00:26:39, localpref 100, from 10.255.255.178
                 AS path: 100 I
                 > via so-1/2/1.0, Push 100019, Push 100008(top)
10.49.201.0/24  *[BGP/170] 00:26:39, MED 0, localpref 100, from
10.255.255.178
                 AS path: 100 I
                 > via so-1/2/1.0, Push 100019, Push 100008(top)
10.255.255.181/32 *[BGP/170] 03:34:59, localpref 100
                 AS path: 100 I
                 > to 192.255.198.14 via so-1/2/0.0
10.255.255.182/32 *[BGP/170] 00:26:39, localpref 100, from 10.255.255.178
                 AS path: 100 I
                 > via so-1/2/1.0, Push 100019, Push 100008(top)
192.255.14.0/24  *[BGP/170] 03:34:59, localpref 100
                 AS path: 100 I
                 > to 192.255.198.14 via so-1/2/0.0
                 [BGP/170] 00:26:39, localpref 100, from 10.255.255.178
                 AS path: 100 I
                 > via so-1/2/1.0, Push 100019, Push 100008(top)
192.255.198.12/30 [BGP/170] 03:34:59, localpref 100
                 AS path: 100 I
                 > to 192.255.198.14 via so-1/2/0.0
192.255.198.20/30 *[BGP/170] 00:26:39, localpref 100, from 10.255.255.178
                 AS path: I
                 > via so-1/2/1.0, Push 100020, Push 100008(top)

mpls.0: 13 destinations, 13 routes (13 active, 0 holddown, 0 hidden)

bgp.l3vpn.0: 6 destinations, 6 routes (6 active, 0 holddown, 0 hidden)
+ = Active Route, - = Last Active, * = Both

10.255.255.178:1:10.49.200.0/24
                 *[BGP/170] 00:27:27, MED 0, localpref 100, from
10.255.255.178
                 AS path: 100 I
                 > via so-1/2/1.0, Push 100019, Push 100008(top)

```

```

10.255.255.178:1:10.49.200.1/32
    *[BGP/170] 00:27:27, localpref 100, from 10.255.255.178
        AS path: 100 I
        > via so-1/2/1.0, Push 100019, Push 100008(top)
10.255.255.178:1:10.49.201.0/24
    *[BGP/170] 00:27:27, MED 0, localpref 100, from
10.255.255.178
        AS path: 100 I
        > via so-1/2/1.0, Push 100019, Push 100008(top)
10.255.255.178:1:10.255.255.182/32
    *[BGP/170] 00:27:27, localpref 100, from 10.255.255.178
        AS path: 100 I
        > via so-1/2/1.0, Push 100019, Push 100008(top)
10.255.255.178:1:192.255.14.0/24
    *[BGP/170] 00:27:27, localpref 100, from 10.255.255.178
        AS path: 100 I
        > via so-1/2/1.0, Push 100019, Push 100008(top)
10.255.255.178:1:192.255.198.20/30
    *[BGP/170] 00:27:27, localpref 100, from 10.255.255.178
        AS path: I
        > via so-1/2/1.0, Push 100020, Push 100008(top)

user@PE3> show route protocol ldp

inet.0: 19 destinations, 20 routes (18 active, 0 holddown, 1 hidden)

inet.3: 5 destinations, 5 routes (5 active, 0 holddown, 0 hidden)
+ = Active Route, - = Last Active, * = Both

10.255.255.175/32  *[LDP/9] 03:35:45, metric 1
                  > via so-1/2/1.0
10.255.255.176/32  *[LDP/9] 00:29:32, metric 1
                  > via so-1/2/1.0, Push 100007
10.255.255.178/32  *[LDP/9] 00:29:32, metric 1
                  > via so-1/2/1.0, Push 100008
10.255.255.179/32  *[LDP/9] 03:34:39, metric 1
                  > via so-1/2/1.0, Push 100001
10.255.255.180/32  *[LDP/9] 03:31:15, metric 1
                  > via so-1/2/1.0, Push 100002

vpn-customer.inet.0: 12 destinations, 14 routes (12 active, 0 holddown, 0
hidden)

mpls.0: 13 destinations, 13 routes (13 active, 0 holddown, 0 hidden)
+ = Active Route, - = Last Active, * = Both

100000             *[LDP/9] 03:35:45, metric 1
                  > via so-1/2/1.0, Pop
100000(S=0)       *[LDP/9] 03:35:45, metric 1
                  > via so-1/2/1.0, Pop
100001             *[LDP/9] 03:34:39, metric 1
                  > via so-1/2/1.0, Swap 100001
100002             *[LDP/9] 03:31:15, metric 1
                  > via so-1/2/1.0, Swap 100002
100011             *[LDP/9] 00:29:32, metric 1
                  > via so-1/2/1.0, Swap 100007
100012             *[LDP/9] 00:29:32, metric 1
                  > via so-1/2/1.0, Swap 100008

bgp.l3vpn.0: 6 destinations, 6 routes (6 active, 0 holddown, 0 hidden)

```

CE1 Status

```

user@CE1> show ldp neighbor
Address          Interface          Label space ID      Hold time
192.255.197.17   t3-0/1/0.0        192.255.197.17:0   11
192.255.198.2    so-1/2/0.0        10.255.255.175:0   14

user@CE1> show route

inet.0: 21 destinations, 23 routes (20 active, 0 holddown, 1 hidden)
+ = Active Route, - = Last Active, * = Both

0.0.0.0/0        *[Static/5] 07:53:10, metric 0
                  Discard
10.255.255.175/32 *[OSPF/10] 00:31:44, metric 1
                  > via so-1/2/0.0
10.255.255.176/32 *[OSPF/150] 00:31:44, metric 1, tag 3489661228
                  > via t3-0/1/0.0
10.255.255.177/32 *[OSPF/10] 00:31:44, metric 2
                  > via so-1/2/0.0
10.255.255.178/32 *[OSPF/150] 00:31:44, metric 1, tag 3489661228
                  > via t3-0/1/0.0
10.255.255.179/32 *[Direct/0] 07:53:10
                  > via lo0.0
10.255.255.180/32 *[OSPF/150] 00:31:44, metric 1, tag 3489661228
                  > via t3-0/1/0.0
172.16.0.0/12    *[Static/5] 07:53:10
                  > to 192.255.14.254 via fxp0.0
192.255.0.0/18    *[Static/5] 07:53:10
                  > to 192.255.14.254 via fxp0.0
192.255.14.0/24   *[Direct/0] 07:53:10
                  > via fxp0.0
192.255.14.179/32 *[Local/0] 07:53:10
                  Local via fxp0.0
192.255.40.0/22   *[Static/5] 03:38:37
                  > to 192.255.14.254 via fxp0.0
192.255.64.0/18   *[Static/5] 03:38:37
                  > to 192.255.14.254 via fxp0.0
192.255.197.16/30 *[Direct/0] 03:37:42
                  > via t3-0/1/0.0
                  [OSPF/10] 00:31:44, metric 2
                  > via t3-0/1/0.0
192.255.197.18/32 *[Local/0] 07:52:01
                  Local via t3-0/1/0.0
192.255.198.0/30  *[Direct/0] 07:51:18
                  > via so-1/2/0.0
                  [OSPF/10] 00:31:44, metric 1
                  > via so-1/2/0.0
192.255.198.1/32  *[Local/0] 07:51:59
                  Local via so-1/2/0.0
192.255.198.8/30  *[OSPF/10] 00:31:44, metric 2
                  > via so-1/2/0.0
207.17.136.192/32 *[Static/5] 07:53:10
                  > to 192.255.14.254 via fxp0.0
224.0.0.5/32     *[OSPF/10] 07:53:14, metric 1
                  MultiRecv

```

```

inet.3: 5 destinations, 5 routes (5 active, 0 holddown, 0 hidden)
+ = Active Route, - = Last Active, * = Both

10.255.255.175/32 *[LDP/9] 01:00:52, metric 1
> via so-1/2/0.0
10.255.255.176/32 *[LDP/9] 00:33:24, metric 1
> via t3-0/1/0.0, Push 100020
10.255.255.177/32 *[LDP/9] 01:00:52, metric 1
> via so-1/2/0.0, Push 100000
10.255.255.178/32 *[LDP/9] 00:33:24, metric 1
> via t3-0/1/0.0, Push 100021
10.255.255.180/32 *[LDP/9] 01:00:52, metric 1
> via t3-0/1/0.0, Push 100015

mpls.0: 6 destinations, 6 routes (6 active, 0 holddown, 0 hidden)
+ = Active Route, - = Last Active, * = Both

100000          *[LDP/9] 03:38:31, metric 1
> via so-1/2/0.0, Pop
100000(S=0)     *[LDP/9] 03:38:31, metric 1
> via so-1/2/0.0, Pop
100001          *[LDP/9] 03:38:31, metric 1
> via so-1/2/0.0, Swap 100000
100002          *[LDP/9] 03:35:06, metric 1
> via t3-0/1/0.0, Swap 100015
100007          *[LDP/9] 00:33:24, metric 1
> via t3-0/1/0.0, Swap 100020
100008          *[LDP/9] 00:33:24, metric 1
> via t3-0/1/0.0, Swap 100021

```

PE1 Status

```

user@PE1> show ldp neighbor ?
Possible completions:
  <[Enter]>      Execute this command
  brief         Show brief status
  detail        Show detailed status
  extensive     Show extensive status
  instance      Particular LDP instance
  |             Pipe through a command
user@PE1> show ldp neighbor instance ?
Possible completions:
  <instance>    Particular LDP instance

user@PE1> show ldp neighbor instance vpn-provider

```

Address	Interface	Label space ID	Hold time
192.255.197.18	t3-0/2/1.0	10.255.255.179:0	11

```

user@PE1> show ldp database instance vpn-provider
Input label database, 192.255.197.17:0--10.255.255.179:0
  Label      Prefix
    3        10.255.255.179/32
100002      10.255.255.180/32
100007      10.255.255.176/32
100001      10.255.255.177/32
100008      10.255.255.178/32
100000      10.255.255.175/32

Output label database, 192.255.197.17:0--10.255.255.179:0
  Label      Prefix
100007      10.255.255.175/32
100020      10.255.255.176/32
100008      10.255.255.177/32
100021      10.255.255.178/32
100006      10.255.255.179/32
100015      10.255.255.180/32

user@PE1> show ldp interface instance vpn-provider
Interface      Label space ID      Nbr count      Next hello
t3-0/2/1.0     192.255.197.17:0   1              0

user@PE1> show ldp path instance vpn-provider
Output Session (label)      Input Session (label)
10.255.255.179:0(100006)(   ) 10.255.255.179:0(3)( )
10.255.255.179:0(100007)     10.255.255.179:0(100000)
10.255.255.179:0(100008)     10.255.255.179:0(100001)
10.255.255.179:0(100015)     ( )
10.255.255.179:0(100020)     ( )
10.255.255.179:0(100021)     ( )

user@PE1> show ldp route instance vpn-provider
Destination      Next-hop intf/lsp      Next-hop address
10.255.255.175/32 t3-0/2/1.0
10.255.255.176/32 so-0/0/0.0
10.255.255.177/32 t3-0/2/1.0
10.255.255.178/32 so-0/0/0.0
10.255.255.179/32 t3-0/2/1.0
10.255.255.180/32 so-0/0/0.0
192.255.197.16/30 t3-0/2/1.0
192.255.197.17/32
192.255.198.0/30  t3-0/2/1.0
192.255.198.8/30 t3-0/2/1.0
224.0.0.5/32

user@PE1> show ldp session instance vpn-provider
Address      State      Connection      Hold time
10.255.255.179 Operational Open            24

```

```
user@PE1> show ldp statistics instance vpn-provider
```

Message type	Total		Last 5 seconds	
	Sent	Received	Sent	Received
Hello	2838	2839	1	2
Initialization	1	1	0	0
Keepalive	1240	1239	0	0
Notification	0	0	0	0
Address	1	1	0	0
Address withdraw	0	0	0	0
Label mapping	10	10	0	0
Label request	0	0	0	0
Label withdraw	4	4	0	0
Label release	4	4	0	0
Label abort	0	0	0	0
All UDP	2837	2839	1	2
All TCP	1258	1251	0	0

Event type	Total	Last 5 seconds
Sessions opened	1	0
Sessions closed	0	0
Topology changes	21	0
No router id	0	0
No address	0	0
No interface	0	0
No session	0	0
No adjacency	0	0
Unknown version	0	0
Malformed PDU	0	0
Malformed message	0	0
Unknown message type	0	0
Inappropriate message	0	0
Malformed TLV	0	0
Bad TLV value	0	0
Missing TLV	0	0
PDU too large	0	0
PDU too small	0	0

```
user@PE1> show ldp traffic-statistics instance vpn-provider
```

FEC	Type	Packets	Bytes	Shared
10.255.255.175/32	Transit	0	0	No
10.255.255.175/32	Ingress	0	0	No
10.255.255.176/32	Transit	0	0	No
10.255.255.177/32	Transit	2798	241984	No
10.255.255.177/32	Ingress	0	0	No
10.255.255.178/32	Transit	1365	125580	No
10.255.255.179/32	Transit	0	0	No
10.255.255.179/32	Ingress	2427	149076	No
10.255.255.180/32	Transit	0	0	No

```
user@PE1> show bgp summary
```

```
Groups: 1 Peers: 1 Down peers: 0
Table Tot Paths Act Paths Suppressed History Damp State Pending
bgp.l3vpn.0 3 3 0 0 0 0
Peer AS InPkt OutPkt OutQ Flaps Last Up/Dwn
State|#Active/Received/Damped...
10.255.255.172 300 428 422 0 0 3:28:37 Establ
bgp.l3vpn.0: 3/3/0
vpn-provider.inet.0: 3/3/0
```

PE2 Status

```

user@PE2> show ldp neighbor ?
Possible completions:
  <[Enter]>      Execute this command
  brief          Show brief status
  detail         Show detailed status
  extensive      Show extensive status
  instance       Particular LDP instance
  |              Pipe through a command

user@PE2> show ldp neighbor instance vpn-provider
Address          Interface          Label space ID    Hold time
192.255.197.38   t1-3/0/0.0        10.255.255.180:0  11

user@PE2> show ldp database instance vpn-provider
Input label database, 192.255.197.37:0--10.255.255.180:0
  Label    Prefix
    3      10.255.255.180/32
 100003    10.255.255.177/32
 100010    10.255.255.178/32
 100009    10.255.255.176/32
 100002    10.255.255.175/32
 100004    10.255.255.179/32

Output label database, 192.255.197.37:0--10.255.255.180:0
  Label    Prefix
 100026    10.255.255.175/32
 100028    10.255.255.179/32
 100027    10.255.255.177/32
 100021    10.255.255.180/32
 100039    10.255.255.178/32
 100037    10.255.255.176/32

user@PE2> show ldp interface instance vpn-provider
Interface          Label space ID    Nbr count  Next hello
t1-3/0/0.0         192.255.197.37:0    1           1

user@PE2> show ldp path instance vpn-provider
Output Session (label)          Input Session (label)
10.255.255.180:0(100021)(      ) 10.255.255.180:0(3)( )
10.255.255.180:0(100026)      ( )
10.255.255.180:0(100027)      ( )
10.255.255.180:0(100028)      ( )
10.255.255.180:0(100037)      10.255.255.180:0(100009)
10.255.255.180:0(100039)      10.255.255.180:0(100010)

user@PE2> show ldp route instance vpn-provider
Destination          Next-hop intf/lsp          Next-hop address
10.255.255.175/32    so-0/2/0.0
10.255.255.176/32    t1-3/0/0.0
10.255.255.177/32    so-0/2/0.0
10.255.255.178/32    t1-3/0/0.0
10.255.255.179/32    so-0/2/0.0
10.255.255.180/32    t1-3/0/0.0
192.255.197.36/30    t1-3/0/0.0
192.255.197.37/32
192.255.198.24/30    t1-3/0/0.0
192.255.198.36/30    t1-3/0/0.0
224.0.0.5/32

```

```
user@PE2> show ldp session instance vpn-provider
```

Address	State	Connection	Hold time
10.255.255.180	Operational	Open	29

```
user@PE2> show ldp statistics instance vpn-provider
```

Message type	Total		Last 5 seconds	
	Sent	Received	Sent	Received
Hello	2948	2939	1	1
Initialization	1	1	0	0
Keepalive	1285	1285	0	0
Notification	0	0	0	0
Address	1	1	0	0
Address withdraw	0	0	0	0
Label mapping	10	10	0	0
Label request	0	0	0	0
Label withdraw	4	4	0	0
Label release	4	4	0	0
Label abort	0	0	0	0
All UDP	2947	2939	1	1
All TCP	1297	1299	0	0

Event type	Total	Last 5 seconds
Sessions opened	1	0
Sessions closed	0	0
Topology changes	33	0
No router id	0	0
No address	0	0
No interface	0	0
No session	0	0
No adjacency	0	0
Unknown version	0	0
Malformed PDU	0	0
Malformed message	0	0
Unknown message type	0	0
Inappropriate message	0	0
Malformed TLV	0	0
Bad TLV value	0	0
Missing TLV	0	0
PDU too large	0	0
PDU too small	0	0

```
user@PE2> show ldp traffic-statistics instance vpn-provider
```

FEC	Type	Packets	Bytes	Shared
10.255.255.175/32	Transit	0	0	No
10.255.255.176/32	Transit	0	0	No
10.255.255.176/32	Ingress	0	0	No
10.255.255.177/32	Transit	3131	274830	No
10.255.255.178/32	Transit	1966	178256	No
10.255.255.178/32	Ingress	0	0	No
10.255.255.179/32	Transit	1	44	No
10.255.255.180/32	Transit	0	0	No
10.255.255.180/32	Ingress	2330	144838	No

```
user@PE2> show bgp summary
```

```
Groups: 1 Peers: 1 Down peers: 0
Table Tot Paths Act Paths Suppressed History Damp State Pending
inet.0 0 0 0 0 0 0 0 0
bgp.l3vpn.0 3 3 0 0 0 0 0 0
Peer AS InPkt OutPkt OutQ Flaps Last Up/Dwn
State|#Active/Received/Damped...
10.255.255.171 300 429 438 0 0 3:33:32 Establ
bgp.l3vpn.0: 3/3/0
vpn-provider.inet.0: 3/3/0
```

```

user@PE2> show route protocol bgp

inet.0: 18 destinations, 19 routes (17 active, 0 holddown, 1 hidden)

inet.3: 3 destinations, 3 routes (3 active, 0 holddown, 0 hidden)

vpn-provider.inet.0: 11 destinations, 15 routes (11 active, 0 holddown, 0
hidden)
+ = Active Route, - = Last Active, * = Both

10.255.255.175/32 *[BGP/170] 00:27:59, MED 1, localpref 100, from
10.255.255.171
                AS path: I
                > via so-0/2/0.0, Push 100012, Push 100028(top)
10.255.255.177/32 *[BGP/170] 00:27:59, MED 1, localpref 100, from
10.255.255.171
                AS path: I
                > via so-0/2/0.0, Push 100013, Push 100028(top)
10.255.255.179/32 *[BGP/170] 00:27:59, MED 1, localpref 100, from
10.255.255.171
                AS path: I
                > via so-0/2/0.0, Push 100014, Push 100028(top)

vpn-provider.inet.3: 3 destinations, 3 routes (3 active, 0 holddown, 0 hidden)

mpls.0: 11 destinations, 11 routes (11 active, 0 holddown, 0 hidden)

vpn-provider.mpls.0: 7 destinations, 7 routes (7 active, 0 holddown, 0 hidden)

bgp.l3vpn.0: 3 destinations, 3 routes (3 active, 0 holddown, 0 hidden)
+ = Active Route, - = Last Active, * = Both

10.255.255.171:1:10.255.255.175/32
                *[BGP/170] 03:33:34, MED 1, localpref 100, from
10.255.255.171
                AS path: I
                > via so-0/2/0.0, Push 100012, Push 100028(top)

10.255.255.171:1:10.255.255.177/32
                *[BGP/170] 03:33:34, MED 1, localpref 100, from
10.255.255.171
                AS path: I
                > via so-0/2/0.0, Push 100013, Push 100028(top)
10.255.255.171:1:10.255.255.179/32
                *[BGP/170] 03:33:34, MED 1, localpref 100, from
10.255.255.171
                AS path: I
                > via so-0/2/0.0, Push 100014, Push 100028(top)

```

CE2 Status

```

user@CE2> show ldp neighbor
Address          Interface          Label space ID      Hold time
192.255.197.37  t1-0/0/0.0        192.255.197.37:0   12
192.255.198.25  t3-0/3/3.0        10.255.255.176:0   13

```

```
user@CE2> show route
```

```
inet.0: 21 destinations, 23 routes (20 active, 0 holddown, 1 hidden)
+ = Active Route, - = Last Active, * = Both
```

```
0.0.0.0/0          *[Static/5] 07:53:49, metric 0
                   Discard
10.255.255.175/32  *[OSPF/150] 00:29:56, metric 1, tag 3489661228
                   > via t1-0/0/0.0
10.255.255.176/32  *[OSPF/10] 00:29:56, metric 2
                   > via t3-0/3/3.0
10.255.255.177/32  *[OSPF/150] 00:29:56, metric 1, tag 3489661228
                   > via t1-0/0/0.0
10.255.255.178/32  *[OSPF/10] 00:29:56, metric 67
                   > via t3-0/3/3.0
10.255.255.179/32  *[OSPF/150] 00:29:56, metric 1, tag 3489661228
                   > via t1-0/0/0.0
10.255.255.180/32  *[Direct/0] 07:53:49
                   > via lo0.0
172.16.0.0/12     *[Static/5] 07:53:49
                   > to 192.255.14.254 via fxp0.0
192.255.0.0/18    *[Static/5] 07:53:49
                   > to 192.255.14.254 via fxp0.0
192.255.14.0/24   *[Direct/0] 07:53:49
                   > via fxp0.0
192.255.14.180/32 *[Local/0] 07:53:49
                   Local via fxp0.0
192.255.40.0/22   *[Static/5] 06:07:28
                   > to 192.255.14.254 via fxp0.0
192.255.64.0/18   *[Static/5] 07:49:39
                   > to 192.255.14.254 via fxp0.0
192.255.197.36/30 *[Direct/0] 03:38:03
                   > via t1-0/0/0.0
                   [OSPF/10] 00:29:56, metric 65
                   > via t1-0/0/0.0
192.255.197.38/32 *[Local/0] 07:52:52
                   Local via t1-0/0/0.0
192.255.198.24/30 *[Direct/0] 03:33:17
                   > via t3-0/3/3.0
                   [OSPF/10] 00:29:56, metric 2
                   > via t3-0/3/3.0
192.255.198.26/32 *[Local/0] 07:52:49
                   Local via t3-0/3/3.0
192.255.198.36/30 *[OSPF/10] 00:29:56, metric 67
                   > via t3-0/3/3.0
207.17.136.192/32 *[Static/5] 07:53:49
                   > to 192.255.14.254 via fxp0.0
224.0.0.5/32     *[OSPF/10] 03:38:55, metric 1
                   MultiRecv
```

```
inet.3: 5 destinations, 5 routes (5 active, 0 holddown, 0 hidden)
+ = Active Route, - = Last Active, * = Both
```

```
10.255.255.175/32 *[LDP/9] 03:35:53, metric 1
                   > via t1-0/0/0.0, Push 100026
10.255.255.176/32 *[LDP/9] 00:34:13, metric 1
                   > via t3-0/3/3.0
10.255.255.177/32 *[LDP/9] 03:35:53, metric 1
                   > via t1-0/0/0.0, Push 100027
10.255.255.178/32 *[LDP/9] 00:34:13, metric 1
                   > via t3-0/3/3.0, Push 100014
10.255.255.179/32 *[LDP/9] 03:35:53, metric 1
                   > via t1-0/0/0.0, Push 100028
```

```

mpls.0: 6 destinations, 6 routes (6 active, 0 holddown, 0 hidden)
+ = Active Route, - = Last Active, * = Both

100002          *[LDP/9] 03:35:53, metric 1
                > via t1-0/0/0.0, Swap 100026
100003          *[LDP/9] 03:35:53, metric 1
                > via t1-0/0/0.0, Swap 100027
100004          *[LDP/9] 03:35:53, metric 1
                > via t1-0/0/0.0, Swap 100028
100009          *[LDP/9] 00:34:13, metric 1
                > via t3-0/3/3.0, Pop
100009(S=0)     *[LDP/9] 00:34:13, metric 1
                > via t3-0/3/3.0, Pop
100010          *[LDP/9] 00:34:13, metric 1
                > via t3-0/3/3.0, Swap 100014

```

PE4 Status

```

user@PE4> show bgp summary
Groups: 2 Peers: 2 Down peers: 0
Table          Tot Paths  Act Paths Suppressed    History Damp State   Pending
bgp.l3vpn.0    6           6           0           0         0     0       0
inet.0         12          10           0           0         0     0       0
Peer           AS           InPkt      OutPkt    OutQ   Flaps Last Up/Dwn
State|#Active/Received/Damped...
192.255.198.22 100          420        429       0       0       3:28:57 Establ
  vpn-customer.inet.0: 5/6/0
10.255.255.177 200          394        406       0       2       28:35 Establ
  bgp.l3vpn.0: 6/6/0
  vpn-customer.inet.0: 5/6/0

```

```

user@PE4> show route protocol bgp

inet.0: 20 destinations, 21 routes (19 active, 0 holddown, 1 hidden)

inet.3: 5 destinations, 5 routes (5 active, 0 holddown, 0 hidden)

vpn-customer.inet.0: 12 destinations, 14 routes (12 active, 0 holddown,
0 hidden)
+ = Active Route, - = Last Active, * = Both

10.49.100.0/24      *[BGP/170] 00:23:27, MED 0, localpref 100, from
10.255.255.177
                    AS path: 100 I
                    > via t1-0/1/1.0, Push 100013, Push 100012(top)
10.49.100.1/32     *[BGP/170] 00:23:27, localpref 100, from 10.255.255.177
                    AS path: 100 I
                    > via t1-0/1/1.0, Push 100013, Push 100012(top)
10.49.101.0/24     *[BGP/170] 00:23:27, MED 0, localpref 100, from
10.255.255.177
                    AS path: 100 I
                    > via t1-0/1/1.0, Push 100013, Push 100012(top)
10.49.200.0/24     *[BGP/170] 03:29:00, MED 0, localpref 100
                    AS path: 100 I
                    > to 192.255.198.22 via t3-0/0/3.0
10.49.200.1/32     *[BGP/170] 03:29:00, localpref 100
                    AS path: 100 I
                    > to 192.255.198.22 via t3-0/0/3.0
10.49.201.0/24     *[BGP/170] 03:29:00, MED 0, localpref 100
                    AS path: 100 I
                    > to 192.255.198.22 via t3-0/0/3.0
10.255.255.181/32  *[BGP/170] 00:23:27, localpref 100, from 10.255.255.177
                    AS path: 100 I
                    > via t1-0/1/1.0, Push 100013, Push 100012(top)
10.255.255.182/32  *[BGP/170] 03:29:00, localpref 100
                    AS path: 100 I
                    > to 192.255.198.22 via t3-0/0/3.0
192.255.14.0/24    *[BGP/170] 03:29:00, localpref 100
                    AS path: 100 I
                    > to 192.255.198.22 via t3-0/0/3.0
                    [BGP/170] 00:23:27, localpref 100, from 10.255.255.177
                    AS path: 100 I
                    > via t1-0/1/1.0, Push 100013, Push 100012(top)
192.255.198.12/30  *[BGP/170] 00:23:27, localpref 100, from 10.255.255.177
                    AS path: I
                    > via t1-0/1/1.0, Push 100014, Push 100012(top)
192.255.198.20/30  [BGP/170] 03:29:00, localpref 100
                    AS path: 100 I
                    > to 192.255.198.22 via t3-0/0/3.0

mpls.0: 13 destinations, 13 routes (13 active, 0 holddown, 0 hidden)

```

```

bgp.l3vpn.0: 6 destinations, 6 routes (6 active, 0 holddown, 0 hidden)
+ = Active Route, - = Last Active, * = Both

10.255.255.177:1:10.49.100.0/24
    *[BGP/170] 00:28:38, MED 0, localpref 100, from
10.255.255.177
    AS path: 100 I
    > via t1-0/1/1.0, Push 100013, Push 100012(top)
10.255.255.177:1:10.49.100.1/32
    *[BGP/170] 00:28:38, localpref 100, from 10.255.255.177
    AS path: 100 I
    > via t1-0/1/1.0, Push 100013, Push 100012(top)
10.255.255.177:1:10.49.101.0/24
    *[BGP/170] 00:28:38, MED 0, localpref 100, from
10.255.255.177
    AS path: 100 I
    > via t1-0/1/1.0, Push 100013, Push 100012(top)
10.255.255.177:1:10.255.255.181/32
    *[BGP/170] 00:28:38, localpref 100, from 10.255.255.177
    AS path: 100 I
    > via t1-0/1/1.0, Push 100013, Push 100012(top)
10.255.255.177:1:192.255.14.0/24
    *[BGP/170] 00:28:38, localpref 100, from 10.255.255.177
    AS path: 100 I
    > via t1-0/1/1.0, Push 100013, Push 100012(top)
10.255.255.177:1:192.255.198.12/30
    *[BGP/170] 00:28:38, localpref 100, from 10.255.255.177
    AS path: I
    > via t1-0/1/1.0, Push 100014, Push 100012(top)

user@PE4> show route protocol ldp

inet.0: 20 destinations, 21 routes (19 active, 0 holddown, 1 hidden)

inet.3: 5 destinations, 5 routes (5 active, 0 holddown, 0 hidden)
+ = Active Route, - = Last Active, * = Both

10.255.255.175/32  *[LDP/9] 00:29:08, metric 1
    > via t1-0/1/1.0, Push 100011
10.255.255.176/32  *[LDP/9] 00:29:08, metric 1
    > via t1-0/1/1.0
10.255.255.177/32  *[LDP/9] 00:29:08, metric 1
    > via t1-0/1/1.0, Push 100012
10.255.255.179/32  *[LDP/9] 00:29:08, metric 1
    > via t1-0/1/1.0, Push 100013
10.255.255.180/32 *[LDP/9] 00:29:08, metric 1
    > via t1-0/1/1.0, Push 100010

vpn-customer.inet.0: 12 destinations, 14 routes (12 active, 0 holddown, 0
hidden)

```

```

mpls.0: 13 destinations, 13 routes (13 active, 0 holddown, 0 hidden)
+ = Active Route, - = Last Active, * = Both

100014          *[LDP/9] 00:29:08, metric 1
                > via t1-0/1/1.0, Pop
100014(S=0)    *[LDP/9] 00:29:08, metric 1
                > via t1-0/1/1.0, Pop
100015          *[LDP/9] 00:29:08, metric 1
                > via t1-0/1/1.0, Swap 100010
100016          *[LDP/9] 00:29:08, metric 1
                > via t1-0/1/1.0, Swap 100011
100017          *[LDP/9] 00:29:08, metric 1
                > via t1-0/1/1.0, Swap 100012
100018          *[LDP/9] 00:29:08, metric 1
                > via t1-0/1/1.0, Swap 100013

bgp.l3vpn.0: 6 destinations, 6 routes (6 active, 0 holddown, 0 hidden)

```

CE4 Status

```

user@CE4> show bgp summary
Groups: 1 Peers: 1 Down peers: 0
Table          Tot Paths  Act Paths  Suppressed    History Damp State    Pending
inet.0         0          0          0             0         0         0         0
Peer           AS         InPkt      OutPkt    OutQ   Flaps Last Up/Dwn
State|#Active/Received/Damped...
192.255.198.21 200       426       421      0      0    3:28:20 5/10/0
0/0/0

user@CE4> show route protocol bgp

inet.0: 20 destinations, 25 routes (19 active, 0 holddown, 6 hidden)
+ = Active Route, - = Last Active, * = Both

10.49.100.0/24  *[BGP/170] 00:28:00, localpref 100
                  AS path: 200 200 I
                  > to 192.255.198.21 via t3-0/0/3.0
10.49.100.1/32  *[BGP/170] 00:28:00, localpref 100
                  AS path: 200 200 I
                  > to 192.255.198.21 via t3-0/0/3.0
10.49.101.0/24  *[BGP/170] 00:28:00, localpref 100
                  AS path: 200 200 I
                  > to 192.255.198.21 via t3-0/0/3.0
10.255.255.181/32 *[BGP/170] 00:28:00, localpref 100
                  AS path: 200 200 I
                  > to 192.255.198.21 via t3-0/0/3.0
192.255.198.12/30 *[BGP/170] 00:28:00, localpref 100
                  AS path: 200 I
                  > to 192.255.198.21 via t3-0/0/3.0

```

For More Information

For additional information about multiple-instance LDP and carrier-of-carriers configuration, see the following resources:

JUNOS Internet Software VPNs Configuration Guide

JUNOS Internet Software MPLS Applications Configuration Guide

JUNOS Internet Software Policy Framework Configuration Guide

Andersson, et. al., *LDP Specification*, RFC 3036, January 2001

Y. Rekhter, E. Rosen, *Carrying Label Information in BGP-4*, RFC 3017, May 2001

Revision History

22 December 2003—6.2R1 Release. Richard Hendricks.

22 September 2003—6.1R1 Release. Richard Hendricks.

30 June 2003—6.0R1 Release. Richard Hendricks.

2 April 2003—5.7R1 Release. Richard Hendricks.

27 December 2002—5.6R1 Release. Richard Hendricks.

30 September 2002—5.5R1 Release. Richard Hendricks.

19 July 2002—5.4R1 Release. Richard Hendricks.

6 May 2002—Initial document written. Richard Hendricks.