

# Chapter 4

## Layer 2 VPN Overview

This chapter provides an overview of Layer 2 Multiprotocol Label Switching (MPLS) virtual private networks (VPNs) as they are implemented in the JUNOS software.

For information about the different types of VPNs, see “VPN Overview” on page 3.

This chapter discusses the following topics:

Layer 2 VPN Overview on page 37

Layer 2 VPN Standards on page 38

### Layer 2 VPN Overview

Implementing a Layer 2 VPN on a router is similar to implementing a VPN using a Layer 2 technology such as Asynchronous Transfer Mode (ATM) or Frame Relay. However, for a Layer 2 VPN on a router, traffic is forwarded to the router in a Layer 2 format. It is carried by MPLS over the service provider’s network, and then converted back to Layer 2 format at the receiving site. You can configure different Layer 2 formats at the sending and receiving sites. The security and privacy of an MPLS Layer 2 VPN are equal to those of an ATM or Frame Relay VPN.

On a Layer 2 VPN, routing occurs on the customer’s routers, typically on the customer edge (CE) router. The CE router connected to a service provider on a Layer 2 VPN must select the appropriate circuit on which to send traffic. The provider edge (PE) router receiving the traffic sends it across the service provider’s network to the PE router connected to the receiving site. PE routers do not need to know the customer’s routes or routing topology; they need to know only in which tunnel to send the data.

For a Layer 2 VPN, customers need to configure their own routers to carry all Layer 3 traffic. The service provider needs to know only how much traffic the Layer 2 VPN will need to carry. The service provider’s routers carry traffic between the customer’s sites using Layer 2 VPN interfaces. The VPN topology is determined by policies configured on the PE routers.

Customers need to know only which VPN interfaces connect to which of their own sites. Figure 3 illustrates a Layer 2 VPN in which each site has a VPN interface linked to each of the other customer sites.

Figure 3: Layer 2 VPN Connecting CE Routers

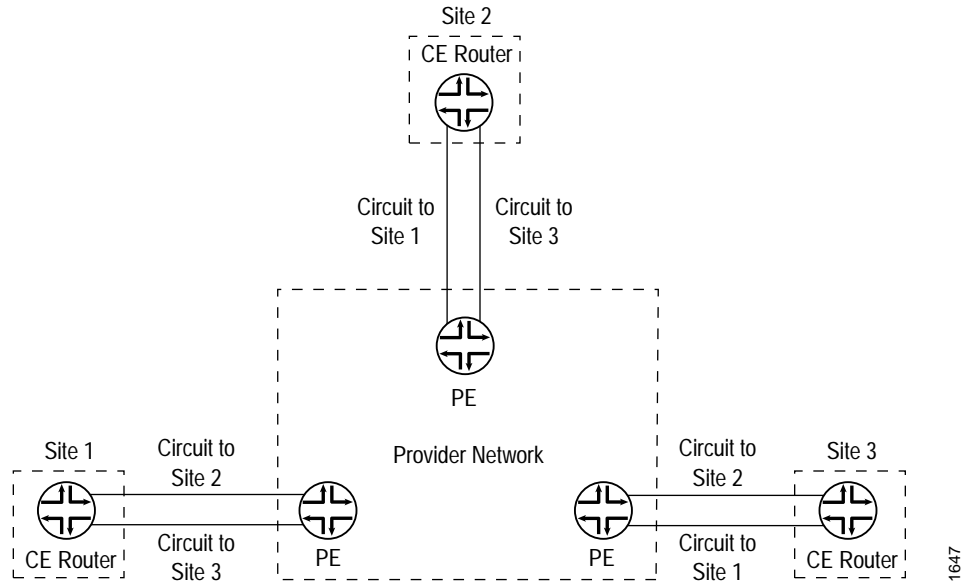

The benefits of implementing a Layer 2 MPLS VPN include:

Service providers do not have to invest in separate Layer 2 equipment to provide Layer 2 VPN service. A Layer 2 MPLS VPN allows you to provide Layer 2 VPN service over an existing IP and MPLS backbone.

You can configure the PE router to run any Layer 3 protocol in addition to the Layer 2 protocols.

Customers who prefer to maintain control over most of the administration of their own networks might want Layer 2 VPN connections with their service provider instead of a Layer 3 VPN.

## Layer 2 VPN Standards

For more information about Layer 2 VPNs, see *MPLS-based Layer 2 VPNs*, Internet draft draft-kompella-ppvnp-l2vpn-02.txt.

You can access Internet Request for Comments (RFCs) and drafts from the Internet Engineering Task Force (IETF) Web site at <http://www.ietf.org>.