

# Chapter 16

## CCC and TCC Overview

This chapter includes the following sections:

CCC Overview on page 229

TCC Overview on page 230

CCC and TCC Graceful Restart on page 231

### CCC Overview

Circuit cross-connect (CCC) allows you to configure transparent connections between two circuits, where a circuit can be a Frame Relay DLCI, an ATM VC, a PPP interface, a Cisco HDLC interface, or an MPLS label-switched path (LSP). Using CCC, packets from the source circuit are delivered to the destination circuit with, at most, the Layer 2 address being changed. No other processing—such as header checksums, TTL decrementing, or protocol processing—is done.

CCC circuits fall into two categories: logical interfaces, which include DLCIs, VCs, VLAN IDs, PPP and Cisco HDLC interfaces; and LSPs. The two circuit categories provide three types of cross-connect:

Layer 2 switching—Cross-connects between logical interfaces provide what is essentially Layer 2 switching. The interfaces that you connect must be of the same type.

MPLS tunneling—Cross-connects between interfaces and LSPs allow you to connect two distant interface circuits of the same type by creating MPLS tunnels that use LSPs as the conduit.

LSP stitching—Cross-connects between LSPs provide a way to “stitch” together two label-switched paths, including paths that fall in two different TED areas.

For Layer 2 switching and MPLS tunneling, the cross-connect is bidirectional, so packets received on the first interface are transmitted out the second interface, and those received on the second interface are transmitted out the first. For LSP stitching, the cross-connect is unidirectional.

## TCC Overview

Translational Cross-Connect (TCC) is a switching concept that allows you to establish interconnections between a variety of Layer 2 protocols or circuits. It is similar to CCC. However, while CCC requires the same Layer 2 encapsulations on each side of a Juniper Networks router (such as PPP-to-PPP or Frame Relay-to-Frame Relay), TCC lets you connect different types of Layer 2 protocols interchangeably. Using TCC, combinations such as PPP-to-ATM (see Figure 24) and Ethernet-to-Frame Relay connections are possible.

Figure 24: TCC Example

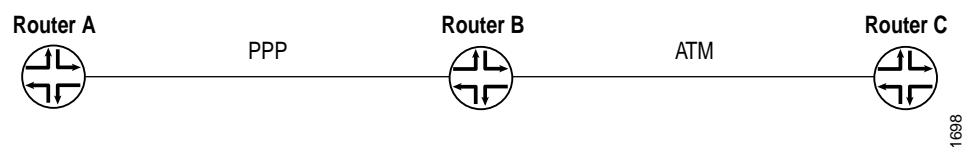

The Layer 2 circuits and encapsulation types that can be interconnected by TCC are:

- Ethernet
- Extended VLANs
- PPP
- HDLC
- ATM
- Frame Relay

TCC works by removing the Layer 2 header when frames enter the router and adding a different Layer 2 header on the frames before they leave the router. In Figure 24, the PPP encapsulation is stripped from the frames arriving at Router B and the ATM encapsulation is added before the frames are sent to Router C.

Note that all control traffic is terminated at the interconnecting router (Router B). Examples of traffic controllers include the Link Control Protocol (LCP) and the Network Control Protocol (NCP) for PPP, keepalives for HDLC, and Local Management Interface (LMI) for Frame Relay.

TCC functionality is different from standard Layer 2 switching. TCC only swaps Layer 2 headers. No other processing, such as header checksums, time-to-live (TTL) decrementing, or protocol handling is performed. TCC is supported for IPv4 only.

You can configure TCC for interface switching and for Layer 2 VPNs. For more information about using TCC for virtual private networks (VPNs), see the *JUNOS Internet Software Configuration Guide: VPNs*.

## CCC and TCC Graceful Restart

CCC and TCC graceful restart allows Layer 2 connections between CE routers to restart gracefully. These Layer 2 connections are configured with the `remote-interface-switch` or `lsp-switch` statements. Because these CCC and TCC connections have an implicit dependency on RSVP LSPs, graceful restart for CCC and TCC uses the RSVP graceful restart capabilities.

RSVP graceful restart must be enabled on the PE routers and P routers to enable graceful restart for CCC and TCC. Also, because RSVP is used as the signaling protocol for signaling label information, the neighboring router must use helper mode to assist with the RSVP restart procedures.

Figure 25 illustrates how graceful restart might work on a CCC connection between two CE routers.

**Figure 25: Remote Interface Switch Connecting Two CE Routers Using CCC**

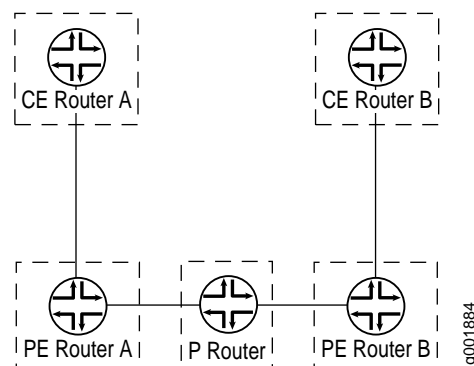

PE Router A is the ingress for the transmit LSP from PE Router A to PE Router B and the egress for the receive LSP from PE Router B to PE Router A. With RSVP graceful restart enabled on all the PE and P routers, the following occurs when PE router A restarts:

- PE Router A preserves the forwarding state associated with the CCC routes (those from CCC to MPLS and from MPLS to CCC).

- Traffic flows without disruption from CE router to CE router.

- After the restart, PE Router A preserves the label for the LSP for which PE Router A is the egress (the receive LSP, for example). The transmit LSP from PE Router A to PE Router B can derive new label mappings, but this should not cause any traffic disruption.

