

Chapter 26

Configure Serial Interfaces

Devices that communicate over a serial interface are divided into two classes: data terminal equipment (DTE) and data circuit-terminating equipment (DCE). Juniper Networks Serial Physical Interface Cards (PICs) have two ports per PIC and support full-duplex data transmission. These PICs support DTE mode only. On the Serial PIC, you can configure three types of serial interfaces:

EIA-530—An Electronics Industries Alliance (EIA) standard for the interconnection of DTE and DCE employing serial binary data interchange with control information exchanged on separate control circuits.

V.35—An ITU-T standard describing a synchronous, physical layer protocol used for communications between a network access device and a packet network. V.35 is most commonly used in the United States and in Europe.

X.21—An ITU-T standard for serial communications over synchronous digital lines. The X.21 protocol is used primarily in Europe and Japan.

The following standards apply to serial interfaces:

TIA/EIA Standard 530, *High-Speed 25-Pin Position Interface for Data Terminal Equipment and Data Circuit-Terminating Equipment*, defines the signals on the cable and specifies the connector at the end of the cable.

TIA/EIA Standard 232, *Interface between Data Terminal Equipment and Data Circuit-Terminating Equipment Employing Serial Binary Data Interchange*, describes the physical interface and protocol for serial data communication.

ITU-T Recommendation V.35, *Data Transmission at 48 kbit/s Using 60-108 kHz Group Band Circuits*. Note that the Juniper Networks Serial PIC supports V.35 interfaces with speeds higher than 48 kilobits per second.

ITU-T Recommendation X.21, *Interface between Data Terminal Equipment and Data Circuit-Terminating Equipment for Synchronous Operation on Public Data Networks*.

To configure serial physical interface properties, include the serial-options statement at the [edit interfaces *se-fpc/pic/port*] hierarchy level:

```
[edit interfaces se-fpc/pic/port]  
serial-options {  
  clock-rate rate;  
  clocking-mode (dce | dte | loop);  
  control-leads {  
    control-signal (assert | de-assert | normal);  
    cts (ignore | normal | require);  
    dcd (ignore | normal | require);  
    dsr (ignore | normal | require);  
    dtr signal-handling-option;  
    ignore-all;  
    indication (ignore | normal | require);  
    rts (assert | de-assert | normal);  
    tm (ignore | normal | require);  
  }  
  control-polarity (positive | negative);  
  cts-polarity (positive | negative);  
  dcd-polarity (positive | negative);  
  dsr-polarity (positive | negative);  
  dtr-circuit (balanced | unbalanced);  
  dtr-polarity (positive | negative);  
  encoding (nrz | nrzi);  
  indication-polarity (positive | negative);  
  line-protocol protocol;  
  loopback mode;  
  rts-polarity (positive | negative);  
  tm-polarity (positive | negative);  
  transmit-clock invert;  
}
```

This chapter discusses configuration of the following serial interface properties:

Configure the Serial Line Protocol on page 347

Configure the Serial Clocking Mode on page 350

Configure the Serial Signal Handling on page 352

Configure the Serial DTR Circuit on page 355

Configure Serial Signal Polarities on page 355

Configure Serial Loopback Capability on page 356

Configure Serial Line Encoding on page 357

There are no serial interface-specific logical properties. For information about general logical properties that you can configure, see “Configure Logical Interface Properties” on page 67.

Configure the Serial Line Protocol

By default, serial interfaces use the EIA-530 line protocol. You can configure each port on the PIC independently to use one of the following line protocols:

EIA-530

V.35

X.21

To configure the serial line protocol, include the line-protocol statement at the [edit interfaces *se-fpc/pic/port* serial-options] hierarchy level, specifying the eia530, v.35, or x.21 option:

```
[edit interfaces se-fpc/pic/port serial-options]
line-protocol protocol;
```

Serial Interface Default Settings

The following sections show the default settings for serial interfaces.

EIA-530 interface default settings

If you do not include the line-protocol statement in the configuration or if you explicitly configure the default EIA-530 line protocol, the default settings are as follows:

```
[edit interfaces se-fpc/pic/port]
serial-options {
  control-leads {
    cts normal;
    dcd normal;
    dsr normal;
    dtr normal;
    rts normal;
    tm normal;
  }
  clock-rate 16.384mhz;
  clocking-mode loop;
  cts-polarity positive;
  dcd-polarity positive;
  dsr-polarity positive;
  dtr-circuit balanced;
  dtr-polarity positive;
  encoding nrz;
  rts-polarity positive;
  tm-polarity positive;
}
```

V.35 interface default settings If you include the line-protocol v.35 statement in the configuration, the default settings are as follows:

```
[edit interfaces se-fpc/pic/port]  
serial-options {  
  control-leads {  
    cts normal;  
    dcd normal;  
    dsr normal;  
    dtr normal;  
    rts normal;  
  }  
  clock-rate 16.384mhz  
  clocking-mode loop;  
  cts-polarity positive;  
  dcd-polarity positive;  
  dsr-polarity positive;  
  dtr-circuit balanced;  
  dtr-polarity positive;  
  encoding nrz;  
  rts-polarity positive;  
}
```

X.21 interface default settings If you include the line-protocol x.21 statement in the configuration, the default settings are as follows:

```
[edit interfaces se-fpc/pic/port]  
serial-options {  
  control-leads {  
    control-signal normal;  
    indication normal;  
  }  
  clock-rate 16.384mhz  
  clocking-mode loop;  
  control-signal-polarity positive;  
  encoding nrz;  
  indication-polarity positive;  
}
```

Serial Interface Invalid Statements

The following sections show the invalid configuration statements for each type of serial interface. If you include the following statements in the configuration, an error message indicates the location of the error and the configuration is not activated.

EIA-530 interface invalid statements If you do not include the line-protocol statement in the configuration or if you explicitly configure the default EIA-530 line protocol, the following statements are invalid:

```
[edit interfaces se-fpc/pic/port]
serial-options {
  control-leads {
    control-signal (assert | de-assert | normal);
    indication (ignore | normal | require);
  }
  control-signal-polarity (positive | negative);
  indication-polarity (positive | negative);
}
```

V.35 interface invalid statements If you include the line-protocol v.35 statement in the configuration, the following statements are invalid:

```
[edit interfaces se-fpc/pic/port]
serial-options {
  control-leads {
    control-signal (assert | de-assert | normal);
    indication (ignore | normal | require);
    tm (ignore | normal | require);
  }
  control-signal-polarity (positive | negative);
  indication-polarity (positive | negative);
  loopback (dce-local | dce-remote);
  tm-polarity (positive | negative);
}
```

X.21 interface invalid statements If you include the line-protocol x.21 statement in the configuration, the following statements are invalid:

```
[edit interfaces se-fpc/pic/port]
serial-options {
  control-leads {
    cts (ignore | normal | require);
    dcd (ignore | normal | require);
    dsr (ignore | normal | require);
    dtr (assert | de-assert | normal);
    rts (assert | de-assert | normal);
    tm (ignore | normal | require);
  }
  clocking-mode (dce | dte);
  cts-polarity (positive | negative);
  dce-polarity (positive | negative);
  dsr-polarity (positive | negative);
  dtr-circuit (balanced | unbalanced);
  dtr-polarity (positive | negative);
  loopback (dce-local | dce-remote);
  rts-polarity (positive | negative);
  tm-polarity (positive | negative);
}
```

Configure the Serial Clocking Mode

By default, serial interfaces use loop clocking mode. For EIA-530 and V.35 interfaces, you can configure each port on the PIC independently to use loop, DCE, or DTE clocking mode. For X.21 interfaces, only loop clocking mode is supported.

The three clocking modes work as follows:

Loop clocking mode—Uses the DCE’s RX clock to clock data from the DCE to the DTE.

DCE clocking mode—Uses the TXC clock, which is generated by the DCE specifically to be used by the DTE as the DTE’s transmit clock.

DTE clocking mode—Also known as line timing, uses an internally generated clock. You can configure the speed of this clock by including the clock-rate statement at the [edit interfaces se-fpc/pic/port serial-options] hierarchy level. For more information about the DTE clock rate, see “Configure the DTE Clock Rate” on page 351.

Note that DCE clocking mode and loop clocking mode use external clocks generated by the DCE. Figure 23 shows the clock sources of loop, DCE, and DTE clocking modes.

Figure 23: Serial Interface Clocking Mode

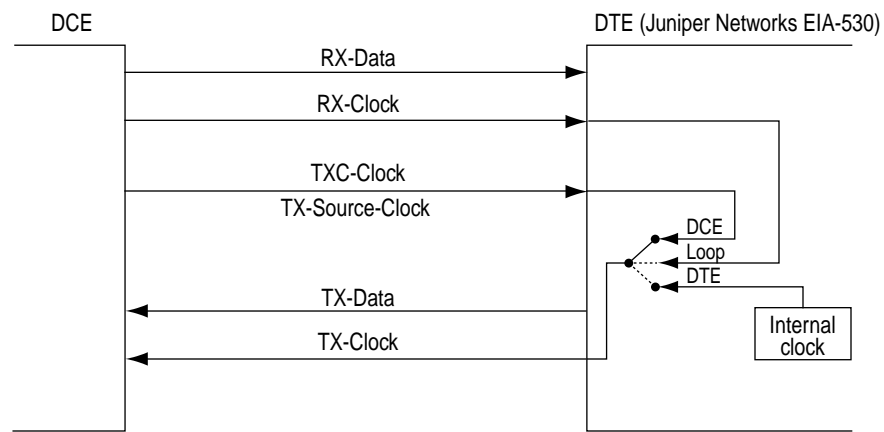

1970

To configure the clocking mode of a serial interface, include the clocking-mode statement at the [edit interfaces se-fpc/pic/port serial-options] hierarchy level:

```
[edit interfaces se-fpc/pic/port serial-options]
clocking-mode (dce | dte | loop);
```

Invert the Serial Interface Transmit Clock

When an externally timed clocking mode (DCE or loop) is used, long cables might introduce a phase shift of the DTE-transmitted clock and data. At high speeds, this phase shift might cause errors. Inverting the transmit clock corrects the phase shift, thereby reducing error rates.

By default, the transmit clock is not inverted. To invert the transmit clock, include the `transmit-clock invert` statement at the [edit interfaces *se-fpc/pic/port* serial-options] hierarchy level:

```
[edit interfaces se-fpc/pic/port serial-options]  
transmit-clock invert;
```

Configure the DTE Clock Rate

By default, the serial interface has a clock rate of 16.384 MHz. For EIA-530 and V.35 interfaces with DTE clocking mode configured, you can configure the clock rate. For more information about DTE clocking mode, see “Configure the Serial Clocking Mode” on page 350.

To configure the clock rate, include the `clock-rate` statement at the [edit interfaces *se-fpc/pic/port* serial-options] hierarchy level:

```
[edit interfaces se-fpc/pic/port serial-options]  
clock-rate rate;
```

You can configure the following interface speeds:

- 2.048 MHz
- 2.341 MHz
- 2.731 MHz
- 3.277 MHz
- 4.096 MHz
- 5.461 MHz
- 8.192 MHz
- 16.384 MHz

Although the serial interface is intended for use at the default rate of 16.384 MHz, you might need to use a slower rate if any of the following conditions prevail:

The interconnecting cable is too long for effective operation.

The interconnecting cable is exposed to an extraneous noise source that might cause an unwanted voltage in excess of + 1 volt measured differentially between the signal conductor and circuit common at the load end of the cable, with a 50-ohm resistor substituted for the generator.

You need to minimize interference with other signals.

You need to invert signals.

For detailed information about the relationship between signaling rate and interface cable distance, see the following standards:

EIA-422-A, *Electrical Characteristics of Balanced Voltage Digital Interface Circuits*

EIA-423-A, *Electrical Characteristics of Unbalanced Voltage Digital Interface Circuits*

Configure the Serial Signal Handling

By default, normal signal handling is enabled for all signals. For each signal, the normal option applies to the normal signal handling for that signal, as defined by the following standards:

TIA/EIA Standard 530

ITU-T Recommendation V.35

ITU-T Recommendation X.21

Table 28 shows the serial interface modes that support each signal type.

Table 28: Signal Handling by Serial Interface Type

Signal	Serial Interfaces
From-DCE signals	
Clear-to-send (CTS)	EIA-530 and V.35
Data-carrier-detect (DCD)	EIA-530 and V.35
Data-set-ready (DSR)	EIA-530 and V.35
Indication	X.21 only
Test-mode (TM)	EIA-530 only
To-DCE signals	
Control-signal	X.21 only
Data-transfer-ready (DTR)	EIA-530 and V.35
Request-to-send (RTS)	EIA-530 and V.35

You configure serial interface signal characteristics by including the control-leads statement at the [edit interfaces *se-fpc/pic/port* serial-options] hierarchy level:

```
[edit interfaces se-fpc/pic/port serial-options]
control-leads {
  control-signal (assert | de-assert | normal);
  cts (ignore | normal | require);
  dcd (ignore | normal | require);
  dsr (ignore | normal | require);
  dtr signal-handling-option;
  ignore-all;
  indication (ignore | normal | require);
  rts (assert | de-assert | normal);
  tm (ignore | normal | require);
}
```

For EIA-530 and V.35 interfaces, you configure to-DCE signals by including the dtr and rts statements at the [edit interfaces *se-fpc/pic/port* serial-options control-leads] hierarchy level, specifying the assert, de-assert, or normal option:

```
[edit interfaces se-fpc/pic/port serial-options control-leads]
dtr (assert | de-assert | normal);
rts (assert | de-assert | normal);
```

For X.21 interfaces, you configure to-DCE signals by including the control-signal statement at the [edit interfaces *se-fpc/pic/port* serial-options control-leads] hierarchy level, specifying the assert, de-assert, or normal option:

```
[edit interfaces se-fpc/pic/port serial-options control-leads]
control-signal (assert | de-assert | normal);
```

Assertion is when the positive side of a given signal is at potential high-level output voltage (Voh), while the negative side of the same signal is at potential low-level output voltage (Vol). *Deassertion* is when the positive side of a given signal is at potential Vol, while the negative side of the same signal is at potential Voh.

For the DTR signal, you can configure normal signal handling using the signal for automatic resynchronization by including the auto-synchronize statement at the [edit interfaces *se-fpc/pic/port* serial-options control-leads dtr] hierarchy level:

```
[edit interfaces se-fpc/pic/port serial-options control-leads dtr]
auto-synchronize {
  duration milliseconds;
  interval seconds;
}
```

The pulse duration of resynchronization can be from 1 through 1000 milliseconds. The offset interval for resynchronization can be from 1 through 31 seconds.

For EIA-530 and V.35 interfaces, you configure from-DCE signals by including the cts, dcd, and dsr statements at the [edit interfaces *se-fpc/pic/port* serial-options control-leads] hierarchy level, specifying the ignore, normal, or require option:

```
[edit interfaces se-fpc/pic/port serial-options control-leads]
cts (ignore | normal | require);
dcd (ignore | normal | require);
dsr (ignore | normal | require);
```

For X.21 interfaces, you configure from-DCE signals by including the indication statement at the [edit interfaces *se-fpc/pic/port* serial-options control-leads] hierarchy level, specifying the ignore, normal, or require option:

```
[edit interfaces se-fpc/pic/port serial-options control-leads]
indication (ignore | normal | require);
```

For EIA-530 interfaces only, you can configure from-DCE test-mode (TM) signaling by including the tm statement at the [edit interfaces *se-fpc/pic/port* serial-options control-leads] hierarchy level, specifying the ignore, normal, or require option:

```
[edit interfaces se-fpc/pic/port serial-options control-leads]
tm (ignore | normal | require);
```

To specify that the from-DCE signal must be asserted, you include the require option in the configuration. To specify that the from-DCE signal must be ignored, you include the ignore option in the configuration. .



Note

For V.35 and X.21 interfaces, you cannot include the tm statement in the configuration.

For X.21 interfaces, you cannot include the cts, dcd, dsr, dtr, and rts statements in the configuration.

For EIA-530 and V.35 interfaces, you cannot include the control-signal and indication statements in the configuration.

For a complete list of serial options statements that are not supported by each serial interface mode, see “Serial Interface Invalid Statements” on page 349.

To return to the default normal signal handling, delete the require, ignore, assert, de-assert, or auto-synchronize statement from the configuration, as shown in the following example:

```
[edit]
user@host# delete interfaces se-0/1/0 serial-options control-leads cts require
```

To explicitly configure normal signal handling, include the normal statement at the [edit interfaces *se-fpc/pic/port* serial-options control-leads *signal*] hierarchy level:

```
[edit interfaces se-fpc/pic/port serial-options control-leads signal]
normal;
```

You can configure the serial interface to ignore all control leads by including the ignore-all statement at the [edit interfaces *se-fpc/pic/port* serial-options control-leads] hierarchy level:

```
[edit interfaces se-fpc/pic/port serial-options control-leads]
ignore-all;
```

You can include the ignore-all statement in the configuration only if you do not explicitly enable other signal handling options at the [edit interfaces *se-fpc/pic/port* serial-options control-leads] hierarchy level.

Configure the Serial DTR Circuit

A balanced circuit has two currents that are equal in magnitude and opposite in phase. An unbalanced circuit has one current and a ground; if a pair of terminals is unbalanced, one side is connected to electrical ground and the other carries the signal. By default, the DTR circuit is balanced.

For EIA-530 and V.35 interfaces, you configure the DTR circuit by including the `dtr-circuit` statement at the `[edit interfaces se-fpc/pic/port serial-options]` hierarchy level:

```
[edit interfaces se-fpc/pic/port serial-options]
dtr-circuit (balanced | unbalanced);
```

Configure Serial Signal Polarities

Serial interfaces use a differential protocol signaling technique. Of the two serial signals associated with a circuit, the one referred to as the A signal is denoted with a plus sign, and the one referred to as the B signal is denoted with a minus sign; for example, DTR+ and DTR-. If DTR is low, then DTR+ is negative with respect to DTR-. If DTR is high, then DTR+ is positive with respect to DTR-.

By default, all signal polarities are positive. You can reverse this polarity on a Juniper Networks serial interface. You might need to do this if signals are miswired as a result of reversed polarities.

For EIA-530 and V.35 interfaces, you configure signal polarities by including the `cts-polarity`, `dcd-polarity`, `dsr-polarity`, `dtr-polarity`, `rts-polarity`, and `tm-polarity` statements at the `[edit interfaces se-fpc/pic/port serial-options]` hierarchy level:

```
[edit interfaces se-fpc/pic/port serial-options]
cts-polarity (positive | negative);
dcd-polarity (positive | negative);
dsr-polarity (positive | negative);
dtr-polarity (positive | negative);
rts-polarity (positive | negative);
tm-polarity (positive | negative);
```

For X.21 interfaces, you configure signal polarities by including the `control-polarity` and `indication-polarity` statements at the `[edit interfaces se-fpc/pic/port serial-options]` hierarchy level:

```
[edit interfaces se-fpc/pic/port serial-options]
control-polarity (positive | negative);
indication-polarity (positive | negative);
```

Configure Serial Loopback Capability

From the router, line interface unit (LIU) loopback loops the TX (transmit) data and TX clock back to the router as RX (receive) data and RX clock. From the line, LIU loopback loops the RX data and RX clock back out the line as TX data and TX clock, as shown in Figure 24.

Figure 24: Serial Interface LIU Loopback

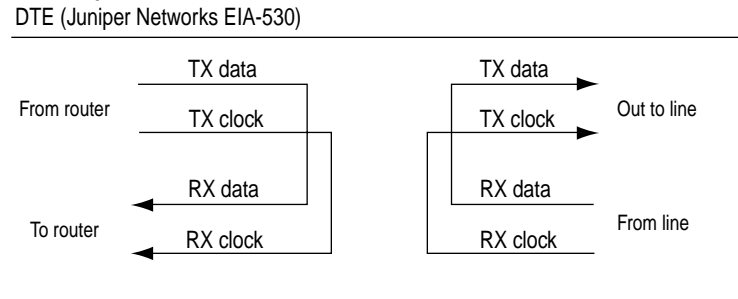

1972

DCE local and DCE remote control the EIA-530 interface-specific signals for enabling local and remote loopback on the link partner DCE. Local loopback is shown in Figure 25.

Figure 25: Serial Interface Local Loopback

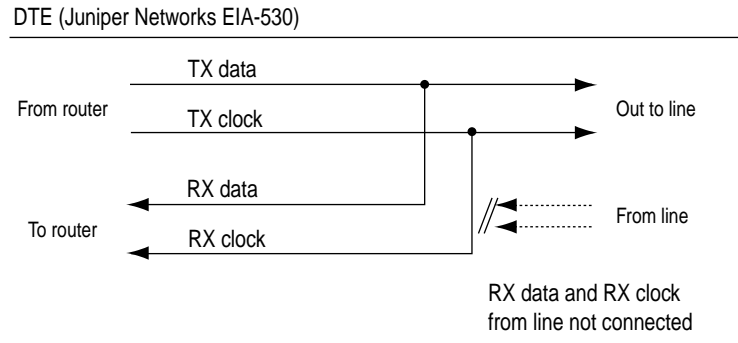

1971

For EIA-530 interfaces, you can configure DCE local, DCE remote, LIU, and local loopback capability.

For V.35 and X.21 interfaces, you can configure LIU and local loopback capability. DCE local and DCE remote loopbacks are not supported on V.35 and X.21 interfaces.

To configure the loopback capability on a serial interface, include the loopback statement at the [edit interfaces *se-fpc/pic/port* serial-options] hierarchy level, specifying the dce-local, dce-remote, liu, or local option:

```
[edit interfaces se-fpc/pic/port serial-options]
loopback mode;
```

To disable the loopback capability, remove the loopback statement from the configuration:

```
[edit]
user@host# delete interfaces se-1/0/0 serial-options loopback
```

Example: Configure Serial Loopback Capability

To determine the source of a problem, loop packets on the local router, the local DCE, the remote DCE, and the line interface unit (LIU). To do this, include the `no-keepalives` and `encapsulation cisco-hdlc` statements at the `[edit interfaces se-fpc/pic/port]` hierarchy level, and the `loopback local` option at the `[edit interfaces se-fpc/pic/port serial-options]` hierarchy level. With this configuration, the link stays up, so you can loop ping packets to a remote router. The `loopback local` statement causes the interface to loop within the PIC just before the data reaches the transceiver.

```
[edit interfaces]
se-1/0/0 {
  no-keepalives;
  encapsulation cisco-hdlc;
  serial-options {
    loopback local;
  }
  unit 0 {
    family inet {
      address 100.100.100.1/24;
    }
  }
}
```

Check the error counters You can determine whether there is an internal or external problem by checking the error counters in the output of the `show interface se-fpc/pic/port extensive` command:

```
> show interfaces se-1/0/0 extensive
```

Configure Serial Line Encoding

By default, serial interfaces use non-return to zero (NRZ) line encoding. You can configure non-return to zero inverted (NRZI) line encoding if necessary.

To have the interface use NRZI line encoding, include the `encoding` statement at the `[edit interfaces se-fpc/pic/port serial-options]` hierarchy level, specifying the `nrzi` option:

```
[edit interfaces se-fpc/pic/port serial-options]
encoding nrzi;
```

To explicitly configure the default NRZ line encoding, include the `encoding` statement at the `[edit interfaces se-fpc/pic/port serial-options]` hierarchy level, specifying the `nrz` option:

```
[edit interfaces se-fpc/pic/port serial-options]
encoding nrz;
```

When setting the line encoding parameter, you must set the same value for paired ports. Ports 0 and 1 must share the same value.

