

Configuring Channelized T3 Interfaces

Use the procedures described in this chapter to configure channelized T3 (CT3) interfaces.

Topic	Page
Overview	1-1
References	1-4
Numbering Scheme	1-5
Before You Configure an Interface	1-9
Configuration Tasks	1-9
Configuration Example	1-20
Testing Interfaces	1-20
Monitoring Interfaces	1-23

Overview

CT3 interfaces are supported by the following modules:

- CT3/T3 line modules and CT3/T3 I/O modules (3 ports)
- CT3/T3-F0 line modules and CT3/T3 12 I/O modules (12 ports)

Configuration procedures for all CT3 interfaces are identical; however, the capabilities of the modules differ. Each port on a CT3 module offers a total bidirectional rate of 43.008 Mbps.

CT3/T3 Line Modules and CT3/T3 I/O Modules

The ERX-700 series and the ERX-1410 system support the CT3/T3 line module and I/O module. The ERX-1440 system does not support the CT3/T3 line module and I/O module.

The ERX-1410 system supports up to twelve CT3/T3 line modules and twelve CT3/T3 I/O modules; the ERX-700 series supports up to five. There are three physical T3 (DS3) ports per CT3/T3 I/O module. Each port uses two BNC connectors: one for the transmit (TX) connection and one for the receive (RX) connection.

CT3/T3 line modules and CT3/T3 I/O modules support the following:

- 28 asynchronous T1 (DS1) channels per T3 port
- 24 64-Kbps DS0 channels per T1 interface
- 384 DS0 channels per line module, distributed in any way across the ports

CT3/T3-F0 Line Modules and CT3/T3 12 I/O Modules

Both the ERX-700 series and the ERX-1400 series support the CT3/T3-F0 line module and CT3/T3 12 I/O module. The CT3/T3-F0 line module and CT3/T3 12 I/O module support both channelized and unchannelized T3 operation. You can configure a mixture of channelized and unchannelized ports on these modules. For information about configuring unchannelized T3 ports, see *Chapter 2, Configuring T3 and E3 Interfaces*.

The ERX-1400 series supports up to twelve CT3/T3-F0 line modules and twelve CT3/T3 12 I/O modules; the ERX-700 series supports up to five. There are twelve physical T3 (DS3) ports per CT3/T3 12 I/O module. Each port uses two SMB connectors: one for the transmit (TX) connection and one for the receive (RX) connection.

CT3/T3-F0 line modules and CT3/T3 12 I/O modules support the following in channelized mode:

- 28 asynchronous T1 (DS1) channels per T3 port
- 24 64-Kbps DS0 channels per T1 interface
- 166 DS0 channels per T3 port

Exchanging Modules

If you replace a CT3/T3 line module and a CT3/T3 I/O module with a CT3/T3-F0 line module and a CT3/T3 12 I/O module or vice versa, you must erase the configuration of the existing modules. See *Replacing Line Modules* in *ERX System Basics Configuration Guide, Chapter 3, Managing Line Modules and SRP Modules*.

Interface Stack

Figure 1-1 shows the stack for a CT3 interface. To configure a CT3 interface, configure a T3 controller, followed by a T1 channel, and then a fractional T1 channel. Finally, you must configure a High-Speed Data Link Control (HDLC) data channel on the interface.

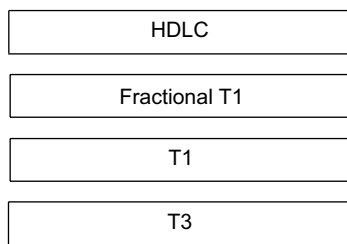

Figure 1-1 Stack for CT3 interface

For more information about the layers in a CT3 interface, see *Numbering Scheme*, later in this chapter.



Note: For a detailed discussion of interface types and specifiers, see the *ERX Command Reference Guide*. For a discussion about interfaces, see the *ERX System Basics Configuration Guide, Chapter 1, Planning Your Network*.

MDL/FDL Support

CT3 interfaces on some line modules support maintenance data link (MDL) messages at the T3 level and facility data link (FDL) messages at the T1 level. For a list of the line modules that support MDL and FDL, see the *Release Notes*.

You can configure CT3 interfaces to send MDL messages that comply with ANSI T1.107a-1990 Standard for Telecommunications – Digital Hierarchy – Supplement to Formats Specification (August 1990). MDL messages identify a particular link by sharing common codes for data such as the equipment identifier, line identifier, frame identifier, and unit.

Similarly, you can configure T1 channels to send FDL messages that comply with either or both of the following standards:

- ANSI T1.403-1989 Standard for Telecommunications – Network and Customer Installation Interfaces – DS1 Metallic Interface – Robbed-bit Signaling State Definitions (1989)

FDL messages that comply with the ANSI standard identify a particular link by sharing common codes for data such as the equipment identifier, line identifier, frame identifier, and unit.

- AT&T Technical Reference 54016 – Requirements for Interfacing Digital Terminal Equipment to Services Employing the Extended Superframe Format (September 1989)

FDL messages that comply with the AT&T standard identify a particular link by sharing performance data and do not use common codes for data such as the equipment identifier, line identifier, frame identifier, and unit.

You can use MDL and FDL messages to determine the status of a link and to display statistics for the remote end of a connection. MDL and FDL messages do not interfere with other data transmitted over the link.

Higher-Level Protocols

See the release notes for information about the higher-level protocols that CT3 interfaces support.

References

CT3 interfaces meet the following specifications:

- RFC 1661 – The Point-to-Point Protocol (PPP) (July 1994)
- RFC 2495 – Definitions of Managed Objects for the DS1, E1, DS2 and E2 Interface Types (January 1999)
- RFC 2496 – Definitions of Managed Objects for the DS3/E3 Interface Types (January 1999)
- ANSI T1.107a-1990 Standard for Telecommunications – Digital Hierarchy – Supplement to Formats Specification (August 1990)

- ANSI T1.403-1989 Standard for Telecommunications – Network and Customer Installation Interfaces – DS1 Metallic Interface – Robbed-bit Signaling State Definitions (1989)
- AT&T Technical Reference 54016 – Requirements for Interfacing Digital Terminal Equipment to Services Employing the Extended Superframe Format (September 1989)

Numbering Scheme

This section describes how to identify each layer in a CT3 interface stack.

T3 Controllers

A T3 controller on a CT3 interface is identified using the *slot/port* format where:

- *slot* – number of the slot in which the line module resides in the chassis. In the ERX-700 series, line module slots are numbered 2-6 (slots 0 and 1 are reserved for SRP modules). In an ERX-1400 series system, line module slots are numbered 0-5 and 8-13 (slots 6 and 7 are reserved for SRP modules).
- *port* – number of the port on the I/O module. On a CT3/T3 I/O module, ports are numbered 0-2; on a CT3/T3 12 I/O module, ports are numbered 0-11.

See Figure 1-2, Figure 1-3, Figure 1-4, and Figure 1-5.

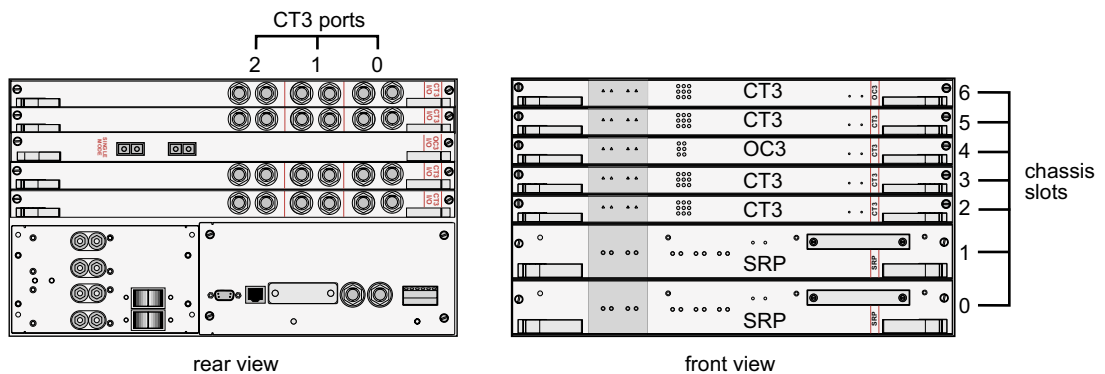

Figure 1-2 CT3/T3 line modules and CT3/T3 I/O modules in the ERX-700 series

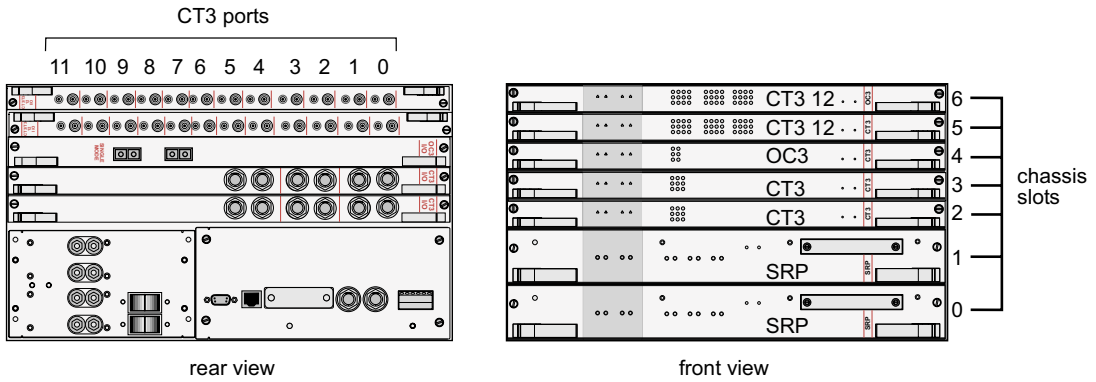

Figure 1-3 CT3/T3-F0 line modules and CT3/T3 12 I/O modules in the ERX-700 series

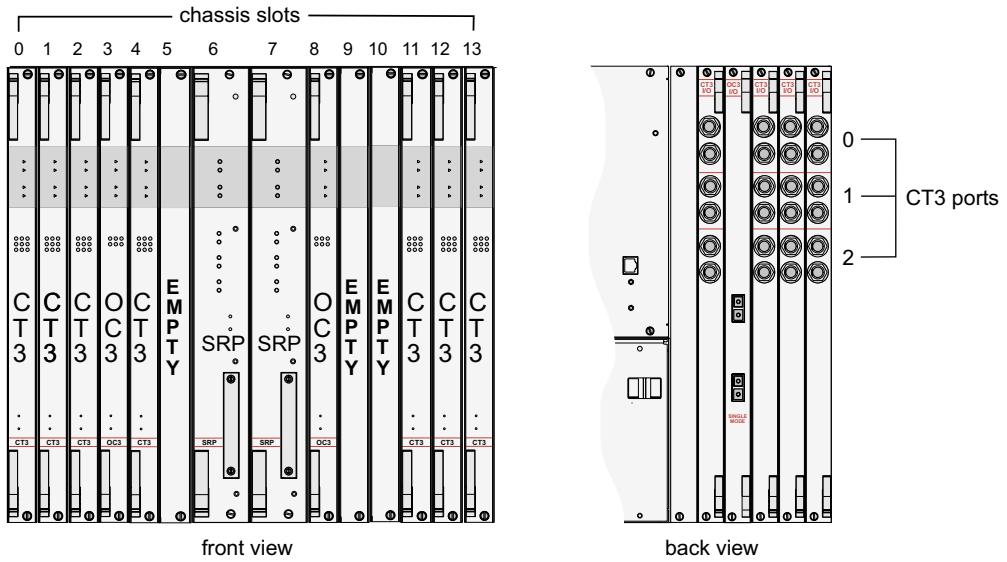

Figure 1-4 CT3/T3 line modules and CT3/T3 I/O modules in ERX-1410 system

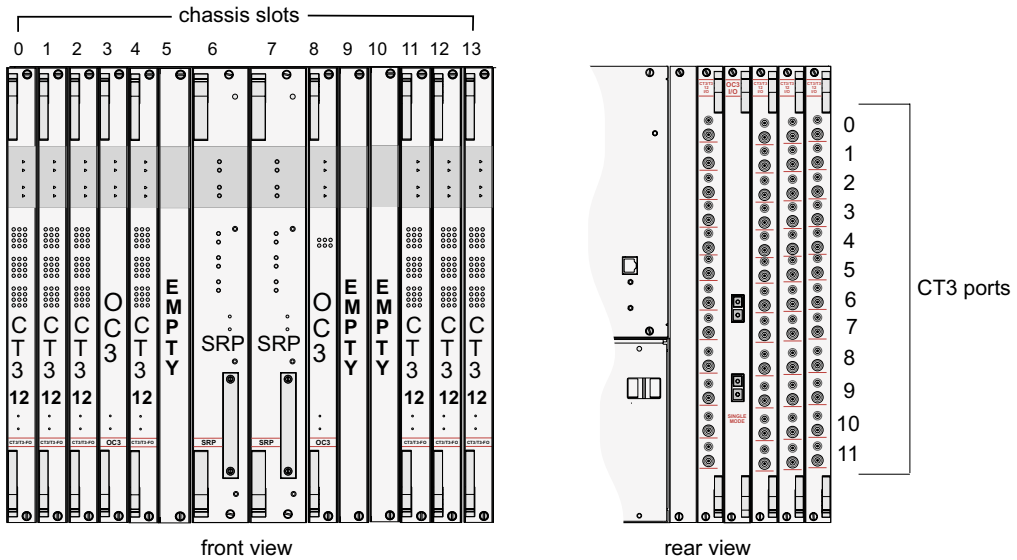

Figure 1-5 CT3/T3-F0 line Modules and CT3/T3 12 I/O Modules in ERX-1400 series

T1 Channels

A T3 line consists of 28 T1 channels (or data streams). A T1 channel is identified by its number in the range 1–28.

Each T1 channel is an aggregate of 24 DS0 timeslots. See Figure 1-6. To configure an entire T1 line, assign 24 timeslots to each channel.

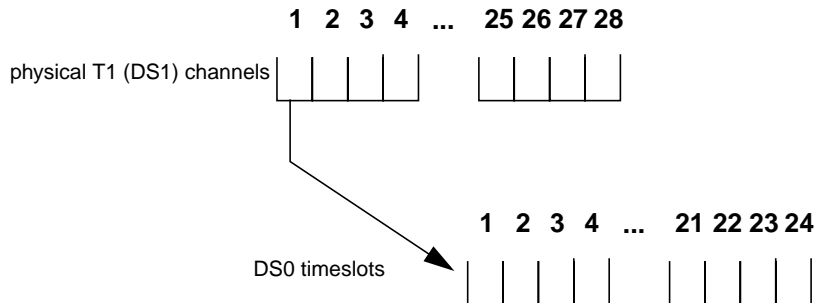

Figure 1-6 T1 Channels and DS0 timeslots on a T3 line

Fractional T1

Fractional T1 is a portion of a T1 line. To configure fractional T1 on a CT3 interface, you assign a range of DS0 timeslots to a T1 channel and *subchannel*. A subchannel is group of timeslots. Subchannel numbers range from 1–24 and do not necessarily correspond to DS0 timeslots. The subchannel number identifies a fractional T1 channel.

For example, you might make the assignments for subchannels 1–6 shown in Table 1-1.

Table 1-1 Sample T1 subchannel/timeslot assignments

Subchannel	DS0 Timeslot
1	1–4, 10, 22–24
2	5–6
3	7–9
4	11
5	12–15, 20–21
6	16–19

To configure the subchannels shown in Table 1-1, use the following command to specify the T3 controller in chassis slot 0, port 1:

```
host1(config)#controller t3 0/1
```

and assign the timeslots to channel 1, subchannel 1:

```
host1(config-controll)#t1 1/1 timeslots 1-4,10,22-24
host1(config-controll)#t1 1/2 timeslots 5-6
host1(config-controll)#t1 1/3 timeslots 7-9
host1(config-controll)#t1 1/4 timeslots 11
host1(config-controll)#t1 1/5 timeslots 12-15,20-21
host1(config-controll)#t1 1/6 timeslots 16-19
```

HDLC Channels

To identify an HDLC channel or the complete CT3 interface, use the format *slot/port:T1 channel/subchannel*. Refer to the sections above for definitions of the variables.

Before You Configure an Interface

Before you configure a CT3 interface, verify the following:

- You have installed the line module and the I/O module correctly.
- Each configured line module is able to transmit data to and receive data from your switch connections.

For more information on installing line modules and I/O modules, see the *ERX Installation and User Guide*.

You should also have the following information available:

- Framing type, clock source, cable length, and the loopback method for each T3 controller
- Framing type, line code, and clock source for each T1 channel
- Timeslot mapping and line speed for each fractional T1 channel
- HDLC channel information, such as data inversion information, cyclic redundancy check (CRC) type, maximum transmission unit (MTU), and maximum receive unit (MRU)

Configuration Tasks

To configure a CT3 interface:

- 1 Configure a T3 controller.
- 2 (Optional) Configure MDL settings.
- 3 (Optional) Configure other settings for the interface.
- 4 Configure T1 channels and subchannels.
- 5 Configure HDLC channels.

Configuring a T3 Controller

To configure a T3 controller:

- 1 Access Controller Configuration mode by specifying the T3 controller.

```
host1(config)#controller t3 0/1
```

- 2 Enable the T3 controller.

T3 controllers are disabled by default.

```
host1(config-controll)#no shutdown
```

controller t3

- Use to specify a T3 controller in *slot/port* format.
 - › *slot* – number of the slot in which the line module resides in the chassis
 - › *port* – number of the port on the I/O module
- Example

```
host1(config)#controller t3 0/1
```
- There is no **no** version.

shutdown

- Use to disable a T3 controller.
- The T3 interface is disabled by default.
- Example

```
host1(config-ctrl)#no shutdown
```
- Use the **no** version to restart a disabled interface.

Configuring MDL Messages

You can configure a CT3 interface to send MDL messages. MDL messages are supported only when T3 framing uses C-bit parity, the default setting.

To configure a CT3 interface to send MDL messages:

- 1 Specify a T3 interface.

```
host1(config)#controller t3 8/0
```

- 2 (Optional) Configure the interface to operate in an MDL carrier environment.

```
host1(config-ctrl)#mdl carrier
```

- 3 Specify the MDL messages.

```
host1(config-ctrl)#mdl string eic "ERX-1400"  
host1(config-ctrl)#mdl string fic "FG786"  
host1(config-ctrl)#mdl string lic "Bldg 10"  
host1(config-ctrl)#mdl string pfi "Site 25"  
host1(config-ctrl)#mdl string port 0800  
host1(config-ctrl)#mdl string unit 080001
```

- 4 Enable transmission of MDL messages.

```
host1(config-ctrl)#mdl transmit path-id  
host1(config-ctrl)#mdl transmit idle-signal  
host1(config-ctrl)#mdl transmit test-signal
```

mdl carrier

- Use to specify that an interface is used in the carrier environment.
- Example

```
host1(config-controll)#mdl carrier
```
- Use the **no** version to restore the default situation, in which the interface does not operate in the carrier environment.

mdl string

- Use to specify an MDL message.
- Example

```
host1(config-controll)#mdl string port 0800
```
- Use the **no** version to restore the default value to the specified MDL message or to all MDL messages.

mdl transmit

- Use to enable transmission of MDL messages.
- Specify the keyword **path-id** to transmit path identifications every second.
- Specify the keyword **idle-signal** to send idle signals every 10 seconds.
- Specify the keyword **test-signal** to transmit test signals every 10 seconds.
- Example

```
host1(config-controll)#mdl transmit test-signal
```
- Use the **no** version to disable transmission of the specified MDL message or all MDL messages.

Other Optional Tasks

The following configuration tasks are optional when you configure a T3 controller:

- Specify a cable length.
- Change the clock source.
- Change the framing format.
- Enable or disable SNMP link status processing.

cablelength

- Use to adjust the transmit power appropriate to the length of the T3 cable.
- Specify a cable length in the range 1–450 feet.
- The system supports two transmit powers, one for a cable length 1–225 feet and another for a cable length 226–450 feet. Therefore, it is not necessary for you to know the exact size of your cable. You only need to know if the cable size is greater than 225 feet. For example, if your cable size is over 220 feet, specify any number greater than 225 (and less than 451).
- Example

```
host1(config-contr0ll)#cablelength 300
```
- Use the **no** version to restore the default value, 0 feet.

clock source

- Use to configure the transmit clock source for a T3 controller.
- Use a transmit clock on the line's receive data stream, except in rare cases such as back-to-back router tests. When performing back-to-back router tests, configure one end of the line as **internal** and the other end as **line**.
- Specify the keyword **line** to use a transmit clock on the line's receive data stream.
- Specify the keywords **internal module** to use the line module's internal clock.
- Specify the keywords **internal chassis** to use the system's clock.
- Example

```
host1(config-contr0ll)#clock source internal module
```
- Use the **no** version to revert to the default, **line**.

framing

- Use to configure the framing format for a T3 controller.
- Specify either **m23** or **c-bit** framing.
- Choose the framing format that is compatible with the framing format of the Telco network device at the other end of the line.
- Select **c-bit** framing if you intend to configure MDL messages.
- Example

```
host1(config-contr0ll)#framing c-bit
```
- Use the **no** version to restore the default value, **c-bit**.

snmp trap link-status

- Use to enable SNMP link status processing on a T3 controller.
- Example

```
host1(config-contr0ll)#snmp trap link-status
```
- Use the **no** version to disable SNMP link status processing.

Configuring T1 Channels

To configure T1 channels and subchannels:

- 1 From Global Configuration mode, specify the T3 controller in slot 0, port 1.

```
host1(config)#controller t3 0/1
```

- 2 Assign a range of timeslots to a channel and subchannel.

For example, assign the following range of timeslots: 1, 3–8, and 10 to channel 2, subchannel 1. Timeslots 2, 9, and 11–24 are available for other subchannels.

```
host1(config-controll)#t1 2/1 timeslots 1,3-8,10
```

Optional Tasks

The following configuration tasks are optional when you configure a T1 channel.

- Disable a T1 channel.
- Change the clock source.
- Change the framing format.
- Change the line coding type.
- Enable or disable SNMP link status processing.
- (Optional) Configure FDL messages.

controller t3

- Use to specify a T3 controller in *slot/port* format.
 - › *slot* – number of the slot in which the line module resides in the chassis
 - › *port* – number of the port on the I/O module
- Example

```
host1(config)#controller t3 0/1
```
- There is no **no** version.

t1 clock source

- Use to configure the transmit clock source for a T1 channel.
- The system supports **internal** and **line clocking**.
 - › If you specify internal clocking, the interface transmits data using the line module or the chassis as the internal clock. You must specify one of the following for internal clocking:
 - **module** – specifies internal clock is from the line module itself
 - **chassis** – specifies internal clock is from the configured system clock
- If you specify line clocking, the interface transmits data from a clock on the line's receive data stream.
- Example

```
host1(config-contr0ll)#t1 2 clock source line
```
- Use the **no** version to restore the default value, **line**.

t1 framing

- Use to configure the framing format for a T1 channel.
- You must specify either **esf** (extended superframe) or **sf** (superframe) framing.
- The framing format you choose must be compatible with the framing format at the other end of the line.
- Example

```
host1(config-contr0ll)#t1 2 framing sf
```
- Use the **no** version to restore the default value, **esf**.

t1 lineCoding

- Use to configure the line code type for a T1 channel.
- The system supports alternate mark inversion (AMI) and B8ZS line coding.
- Example

```
host1(config-contr0ll)#t1 2 linecoding ami
```
- Use the **no** version to restore the default value, **b8zs**.

t1 shutdown

- Use to disable a T1 channel or subchannel.
- To disable a channel or subchannel, you specify a T1 channel in *channel* or *channel/subchannel* format.
 - › *channel* – T1 channel in the range 1–28
 - › *subchannel* – subchannel from 1–24
- The T1 interface is enabled by default.
- Example

```
host1(config-contr0ll)#t1 2 shutdown
```
- Use the **no** version to restart a disabled interface.

t1 snmp trap link-status

- Use to enable SNMP link status processing on a T1 channel.
- To enable or disable SNMP on an interface, specify a T1 channel or subchannel in *channel* or *channel/subchannel* format.
 - › *channel* – T1 channel in the range 1–28
 - › *subchannel* – subchannel from 1–24
- Example

```
host1(config-contr0ll)#t1 2 snmp trap link-status
```
- Use the **no** version to disable SNMP link status processing.

t1 timeslots

- Use to assign a range of DS0 timeslots to a subchannel as a single data stream.
- To configure a subchannel, specify a T1 channel in *channel/subchannel* format and a range of timeslots.
 - › *channel* – T1 channel in the range 1–28
 - › *subchannel* – number from 1– 4
 - › dash – represents a range of timeslots; a comma separates timeslots. For example, 1-10, 15-8 assigns timeslots 1–10 and 15–18.
- Example

```
host1(config-contr0ll)#t1 2/1 timeslots 1,3-8,10
```
- You can specify a line speed that applies to all DS0 timeslots assigned to a subchannel. The default line speed is 64 Kbps.
- Use the **no** version to delete the fractional T1 circuit.

Configuring FDL Messages

To configure a T1 channel to send FDL messages:

- 1 Specify a T3 interface.

```
host1(config)#controller t3 8/0
```

- 2 Specify the standard for transmission of FDL messages on both ends of the T1 connection.

```
host1(config-contr0ll)#t1 1 fdl ansi
```

- 3 (Optional) Configure the T1 channel to operate in an FDL carrier environment.

```
host1(config-contr0ll)#t1 1 fdl carrier
```

- 4 (ANSI signals) Specify the FDL messages.

```
host1(config-controll)#t1 1 fdl string eic "ERX-1400"
host1(config-controll)#t1 1 fdl string fic "HY0019"
host1(config-controll)#t1 1 fdl string lic "Bldg 10"
host1(config-controll)#t1 1 fdl string unit 080001
```

- 5 Enable transmission of FDL messages.

```
host1(config-controll)#t1 1 fdl transmit path-id
```

- 6 (Optional) Specify that the system should generate yellow alarms for the T1 channel.

```
host1(config-controll)#t1 1 yellow generate
```

- 7 (Optional) Specify that the system should detect yellow alarms for the T1 channel.

```
host1(config-controll)t1 1 yellow detect
```

t1 fdl

- Use to specify the FDL standard for the channel.
- Specify the T1 channel with a number from 1 through 28.
- Specify the keyword **ansi** to support the ANSI FDL standard (see *References* earlier in this chapter).
- Specify the keyword **att** to support the AT&T FDL standard (see *References* earlier in this chapter).
- Specify the keyword **all** to support both the ANSI and AT&T standards
- Specify the keyword **none** to remove the current FDL mode settings
- You can configure a different standard on each T1 channel.
- Example

```
host1(config-controll)#t1 14 fdl att
```
- Use the **no** version to restore the default, none.

t1 fdl carrier

- Use to specify that a T1 channel is used in the carrier environment.
- Example

```
host1(config-controll)#t1 6 fdl carrier
```
- Use the **no** version to restore the default situation, in which the T1 channel does not operate in the carrier environment.

t1 fdl string



- Use to specify an FDL message as defined in the ANSI T1.403 specification.

Note: The system sends these FDL messages only if you have issued the **t1 fdl** command with the **ansi** or **all** keyword and then issued the **t1 fdl transmit** command.

- Example

```
host1(config-controll)#t1 6 fdl string eic "RX-1440"
```

- Use the **no** version to restore the default value to the specified FDL message or to all FDL messages.

t1 fdl transmit



- Use to configure the system to send the specified type of FDL message.
- By default, the system sends only FDL performance data messages.

Note: The system sends FDL messages specified with the **t1 fdl string** command only if you have issued the **t1 fdl** command with the **ansi** or **all** keyword. If you specified the **att** keyword with the **t1 fdl** command, the system sends only performance data.

- Specify the keyword **path-id** to transmit path identifications every second.
- Specify the keyword **idle-signal** to send idle signals every 10 seconds.
- Specify the keyword **test-signal** to transmit test signals every 10 seconds.
- Example

```
host1(config-controll)#t1 28 fdl transmit path-id
```

- Use the **no** version to disable transmission of the specified FDL message or all FDL messages.

t1 yellow detect

- Use to detect yellow alarm for a T1 channel.
- By default, a T1 channel detects alarms.
- Example:

```
host1(config-controll)#t1 6 yellow detect
```

- Use the **no** version to disable detection of yellow alarms.

t1 yellow generate

- Use to generate a yellow alarm when a loss of frame or loss of signal condition is detected on a T1 channel.
- By default, a T1 channel generates alarms.
- Example:

```
host1(config-controll)#t1 6 yellow generate
```

- Use the **no** version to disable generation of yellow alarms.

Configuring an HDLC Channel

You must configure an HDLC channel for each group of fractional T1 lines and each full T1 line.

To configure an HDLC channel, specify a serial interface (for example, HDLC channel in slot 0, port 1, channel 1, subchannel 5).

```
host1(config)#interface serial 0/1:1/5
```

Optional Tasks

The following configuration tasks are optional when you configure an HDLC channel on a CT3 interface:

- Configure the CRC.
- Enable data inversion on the interface.
- Set the time interval for monitoring bit and packet rates.
- Set the MRU.
- Set the MTU.

crc

- Use to configure the size of the CRC.
- The CRC is an error-checking technique that uses a calculated numeric value to detect errors in transmitted data.
- 16 and 32 indicate the number of bits per frame that are used to calculate the frame check sequence (FCS). Both the sender and receiver must use the same setting.
- A 32-bit CRC transmits longer streams at faster rates and therefore provides better ongoing error detection.
- Example

```
host1(config-ifs)#crc 32
```

- Use the **no** version to restore the default value, 16.

interface serial

- Use to configure a serial interface in the *slot/port:channel/subchannel* format.
 - › *slot* – number of the slot in which the line module resides in the chassis
 - › *port* – number of the port on the I/O module
 - › *channel* – T1 channel
 - › *subchannel* – subchannel in the range 1–24

- Example

```
host1(config)#interface serial 0/1:1/5
```

- Use the **no** version to disable the interface.

invert data

- Use to enable data stream inversion for the interface.
- Enable data stream inversion only if it is turned on at the other end of the line.
- Example

```
host1(config-if)#invert data
```

- Use the **no** version to disable data inversion.

load-interval

- Use to set the time interval at which the system calculates bit and packet rate counters.
- You can choose a multiple of 30 seconds, in the range 30–300 seconds.
- Example

```
host1(config-if)#load-interval 90
```

- Use the **no** version to restore the default value, 300 seconds.

mru

- Use to configure the MRU size for the interface.
- You should coordinate this value with the network administrator on the other end of the line.
- If you configure a different MRU value in higher-level protocols, such as IP, the system uses the lower value. This can produce unexpected behavior in your network.
- Example

```
host1(config-if)#mru 1600
```

- Use the **no** version to restore the default, 1600 bytes.

mtu

- Use to configure the MTU size for the interface.
- You should coordinate this value with the network administrator on the other end of the line.
- If you configure a different MTU value in higher-level protocols, such as IP, the system uses the lower value. This can produce unexpected behavior in your network.
- Example

```
host1(config-if)#mtu 1600
```

- Use the **no** version to restore the default, 1600 bytes.

Configuration Example

The following example illustrates how to configure the layers on a CT3 interface.

```
host1(config)#controller t3 0/1
host1(config-controll)#no shutdown
host1(config-controll)#framing c-bit
host1(config-controll)#clock source internal module
host1(config-controll)#cablelength 220
host1(config-controll)#t1 2 framing esf
host1(config-controll)#t1 2 lineCoding b8zs
host1(config-controll)#t1 2 clock source internal
host1(config-controll)#t1 2 loopback local
host1(config-controll)#t1 2/1 timeslots 1,3-8,10
host1(config-controll)#exit
host1(config)#interface serial 0/1:2/1
host1(config-if)#invert data
host1(config-controll)#exit
```

Testing Interfaces

If you want to run loopback tests or bit error rate tests (berts) on CT3 interfaces, you must enable testing at the T3 or T1 layer. See *Interface Stack*, earlier in this chapter, for a description of the layers.

Testing at the T3 Layer

To enable testing at the T3 layer, use the **clock source** and **loopback** commands:

- 1 Change the clock source to internal.

```
host1(config-controll)#clock source internal module
```

- 2 Configure one of the following loopback tests.

Set the loopback to **local** to test the line without connecting to the network.

```
host1(config-controll)#loopback local
```

Set the loopback to **network** to test the line connected to the network.

```
host1(config-controll)#loopback network line
```

loopback

- Use to configure a loopback.
- Specify either **local**, **network**, or **payload**.
 - › **local** loopback loops the data back toward the router and sends an alarm indication signal (AIS) out toward the network.
 - › **network** loopback loops the data toward the network before the framer processes the data.
 - › **payload** loopback loops the data toward the network after the framer processes the data.
- Example

```
host1(config-ctrl1)#loopback local
```
- Use the **no** version to restore the default configuration, no loopback.

Testing at the T1 Layer

To enable testing at the T1 layer:

- 1 Configure one of the following loopback tests.
 - Set the loopback to **local** to test the line without connecting to the network.

```
host1(config-ctrl1)#t1 2 loopback local
```
 - Set the loopback to **network** to test the line connected to the network.

```
host1(config-ctrl1)#t1 2 loopback network line
```
 - Set the loopback to **remote** to allow testing from the remote end.

```
host1(config-ctrl1)#t1 2 remote-loopback
```
- 2 Configure the line to run bit error rate tests.

```
host1(config-ctrl1)#t1 2 bert pattern 2^11 time 10 unframed
```

t1 bert

- Use to enable bit error rate tests using the specified pattern on a T1 line.
- Unlike other configuration commands, **bert** is not stored in NVRAM.
- Specify one of the following options:



Note: The CT3/T3-F0 line module supports only the **2^11**, **2^15**, and **2^20-0153** options.

- › **0s** – repetitive test pattern of all zeros, 00000...
- › **1s** – repetitive test pattern of all ones, 11111...
- › **2^11** – pseudorandom test pattern, 2048 bits in length
- › **2^15** – pseudorandom 0.151 test pattern, 32768 bits in length
- › **2^20-0153** – pseudorandom 0.153 test pattern, 1048575 bits in length
- › **2^20-QRSS** – pseudorandom QRSS 0.151 test pattern, 1048575 bits in length
- › **2^23-** – pseudorandom 0.151 test pattern, 8388607 bits in length
- › **alt-0-1** – repetitive alternating test pattern of zeros and ones, 01010101...
- Specify the time interval between the tests in the range 1–14,400 minutes.
- Optionally, specify the unframed keyword to overwrite the framing bits.
- Example

```
host1(config-controll)#t1 2 bert pattern 2^11 time 10
unframed
```

- Use the **no** version to stop the test that is running.

t1 loopback

- Use to configure a loopback.
- Specify one of the following options:



Note: The CT3/T3-F0 line module does not support the **remote line inband** option.

- › **local** – loops the router output data back toward the router at the T1 framer and sends an alarm indication signal (AIS) out toward the network
- › **network { line | payload }** – Specify the **line** keyword to loop the data back toward the network before the T1 framer and automatically set a local loopback at the HDLC controllers. Specify the **payload** keyword to loop the payload data back toward the network at the T1 framer and automatically set a local loopback at the HDLC controllers.
- › **remote line fdl ansi** – sends a repeating 16-bit ESF data link code word (00001110 11111111) to the remote end requesting that it enter into a network line loopback. Specify the **ansi** keyword to enable the remote line facility data link (FDL) ANSI bit loopback on the T1 channel, according to the ANSI T1.403 Specification.
- › **remote line fdl bellcore** – sends a repeating 16-bit ESF data link code word (00010010 11111111) to the remote end requesting that it enter into a network line loopback. Specify the **bellcore** keyword to enable the remote line facility data link (FDL) Bellcore bit loopback on the T1 channel, per the Bellcore TR-TSY-000312 Specification.

- › **remote line inband** – sends a repeating 5-bit inband pattern (00001) to the remote end requesting that it enter into a network line loopback
- › **remote payload [fdl] [ansi]** – sends a repeating, 16-bit, ESF data link code word (00010100 11111111) to the remote end requesting that it enter into a network payload loopback. Enables the remote payload facility data link (FDL) ANSI bit loopback on the T1 channel. You can optionally specify **fdl** and **ansi**.
- If you do not specify an option, the system will set a local loopback for the channel.
- Example

```
host1(config-controll)#t1 2 loopback local
```
- Use the **no** version to deactivate loopback. If you specify the remote keyword, the **no** version sends the 16-bit ESF data link code word or inband pattern to deactivate the loopback at the remote end based on the last activate request sent to the remote end. If you do not specify the **remote** keyword, the **no** version clears the local loopback configuration.

t1 remote-loopback

- Use to enable the acceptance of remote loopback requests.
- Example

```
host1(config-controll)#t1 2 remote-loopback
```
- Use the **no** version to restore the factory default, which is to reject remote loopback requests.

Monitoring Interfaces

From User Exec mode, use the following **show** commands to monitor and display the T3 interface, T1 interface, and HDLC serial data channel information:

- Monitor CT3 interfaces on a slot and port.

```
host1>show controllers t3 0/1
```
- Monitor a T1 interface.

```
host1>show controllers t3 0/1:1
```
- Monitor fractional T1 subchannels.

```
host1>show controllers t3 ft1
```
- Monitor the state of the serial interface or a slot/port.

```
host1>show controllers t3 serial 0/1
```

Setting a Baseline

You can set a statistics baseline for serial interfaces, subinterfaces, and/or circuits using the **baseline interface serial** command. Use the **delta** keyword with the **show** commands to display statistics with the baseline subtracted.

Displaying Counters and Time Intervals

Counters and time intervals are MIB statistics, which are defined in the following specifications:

- RFC 2495 – Definitions of Managed Objects for the DS1, E1, DS2 and E2 Interface Types (January 1999)
- RFC 2496 – Definitions of Managed Objects for the DS3/E3 Interface Types (January 1999)

The **show controllers t3 slot/port all** command displays the following information:

- T3 current interval counters – counters for the current interval
- T3 last interval counters – counters for the previous interval
- T3 24-hour total counters – cumulative counters for the last 24 hours or since the interface was started
- The last 24 hours of 15-minute reporting intervals (96 intervals)

The **show controllers t3 slot/port:channel all** command displays the following information:

- T1 current interval counters – counters for the current interval
- T1 last interval counters – counters for the previous interval
- T1 24-hour total counters – cumulative counters for the last 24 hours or since the interface was started
- The last 24 hours of 15-minute reporting intervals (96 intervals)

Output Filtering

You can use the output filtering feature of the **show** command to include or exclude lines of output based on a text string you specify. Refer to *ERX System Basics Configuration Guide, Chapter 2, Command Line Interface*, for details.

baseline interface serial

- Use to set a statistics baseline for serial interfaces.
- The system implements the baseline by reading and storing the statistics at the time the baseline is set and subtracting this baseline whenever baseline-relative statistics are retrieved.
- Use the optional **delta** keyword with the **show interfaces serial** commands to view the baseline statistics.
- Example

```
host1#baseline interface serial 2/0:1/1
```
- There is no **no** version.

show controllers t3

- Use to display data and MIB statistics for a T3 interface or a T1 channel.
- For definitions of the MIB statistics for a T3 interface, see RFC 2496 – Definitions of Managed Objects for the DS3/E3 Interface Types (January 1999).
- For definitions of the MIB statistics for a T1 channel, see RFC 2495 – Definitions of Managed Objects for the DS1, E1, DS2 and E2 Interface Types (January 1999).
- Field descriptions for T3 interface (T1 channel not specified)
 - › ifAdminStatus – one of the following administrative states of the interface:
 - ifAdminUp – interface is administratively enabled
 - ifAdminDown – interface is administratively disabled
 - ifAdminTesting – interface is administratively configured in a testing state
 - › snmp trap link-status – status of SNMP trapping (enabled or disabled)
 - › alarms detected – one of the following T3 alarms:
 - No alarm present – no alarms present on the line
 - Rcv RAI Failure – remote device is sending a far end alarm failure
 - Xmt RAI Failure – local device is sending a far end alarm failure
 - Rcv AIS – remote device is sending an alarm indication signal (AIS)
 - Xmt AIS – local device is sending an AIS
 - Rcv LOF – loss of one or more frames from the remote end
 - Rcv LOS – loss of signal at the local end
 - Undefined line status – indicates that the line is in an undefined state



Note: *The alarms detected field does not appear for interfaces that you disabled in the software.*

- › framing – type of framing format
- › line code – type of line code format
- › clock source – type of clock source
- › cable length – cable length in feet

- › Loopback – state of loopback for the controller: enabled or disabled. If loopback is enabled, one of the following states is displayed:
 - Diagnostic – loops the data back toward the router and sends an AIS toward the network
 - Payload – loops the data toward the network after the framer has processed the data
 - Line – loops the data toward the network before the data reaches the framer
- › MDL Transmit Path – status of path transmission: active or not active
- › MDL Transmit Test-Signal – status of test signal: active or not active
- › MDL Transmit Idle-Signal – status of idle signal: active or not active
- › Equipment Identification Code – eic string for MDL
- › Line Identification Code – lic string for MDL
- › Frame Identification Code – fic string for MDL
- › Unit Identification Code – unit string for MDL
- › Facility Identification Code – pfi string for MDL
- › Port Code – port string for MDL
- › Generator Number – generator string for MDL
- › number of valid intervals – number of 15-minute intervals since the line module was last powered on or reset
- › Time elapse in current interval – reported in 15-second intervals
- › P-bit errored seconds – number of errored seconds encountered by a T3 in the current interval
- › P-bit severely errored seconds – number of severely errored seconds encountered by a T3 in the current interval
- › Severely errored frame seconds – number of severely errored framing seconds encountered by a T3 in the current interval
- › Unavailable seconds – number of unavailable seconds encountered by a T3 in the current interval
- › Line code violations – number of line code violations encountered by a T3 in the current interval
- › P-bit coding violations – number of coding violations encountered by a T3 in the current interval
- › Line errored seconds – number of line errored seconds encountered by a T3 in the current interval
- › C-bit coding violations – number of C-bit coding violations encountered by a T3 in the current interval
- › C-bit errored seconds – number of C-bit errored seconds encountered by a T3 in the current interval
- › C-bit severely errored seconds – number of C-bit severely errored seconds encountered by a T3 in the current interval

- Example: In this example, a T3 interface is specified.

```
host1>show controllers t3 2/0
```

```
DS3 2/0
ifAdminStatus = ifAdminDown
snmp trap link-status = enabled
No alarms detected
Framing is C-BIT, Line Code is B3ZS, Clock Source is Line
Cable Length is 0 ft
Loopback Disabled
MDL Transmit Path is not active
MDL Transmit Test-Signal is active
MDL Transmit Idle-Signal is not active
Equipment Identification Code is ERX-1400
Line Identification Code is Bldg 10
Frame Identification Code is null string
Unit Identification Code is 080001
Facility Identification Code is Site 25
Port Code is Port 0800
Generator Number is null string
Number of valid interval - 96
Time elapse in current interval - 861
```

```
Ds3 Current Interval Counters
```

```
P-bit errored seconds          = 0
P-bit severely errored seconds = 0
Severely errored frame seconds = 0
Unavailable seconds           = 0
Line code violations           = 0
P-bit coding violations        = 0
Line errored seconds          = 0
C-bit coding violations        = 0
C-bit errored seconds         = 0
C-bit severely errored seconds = 0
```

```
Ds3 Last Interval Counters
```

```
P-bit errored seconds          = 0
P-bit severely errored seconds = 0
Severely errored frame seconds = 0
Unavailable seconds           = 0
Line code violations           = 0
P-bit coding violations        = 0
Line errored seconds          = 0
C-bit coding violations        = 0
C-bit errored seconds         = 0
C-bit severely errored seconds = 0
```

```

Ds3 24 Hour Total Counters
P-bit errored seconds           = 0
P-bit severely errored seconds = 0
Severely errored frame seconds = 0
Unavailable seconds            = 0
Line code violations            = 0
P-bit coding violations         = 0
Line errored seconds           = 0
C-bit coding violations         = 0
C-bit errored seconds          = 0
C-bit severely errored seconds = 0

```

- Field descriptions for a T1 channel
 - › ifOperStatus – physical state of the interface:
 - ifOperDown – interface is not functioning
 - ifOperLowerLayerDown – lower layer in the interface stack is not functioning
 - ifOperNotPresent – module has been removed from the chassis
 - ifOperTesting – interface is being tested
 - ifOperUp – interface is functioning
 - › Yellow Alarm detection – status of yellow alarm detection: active or not active
 - › Yellow Alarm generation – status of yellow alarm generation: active or not active
 - › snmp trap link-status – status of SNMP trapping (enabled or disabled)
 - › Framing – type of framing format
 - › Line code – type of line code format
 - › Clock source – type of clock source
 - › Loopback state – type of loopback (if enabled) and status: enabled or disabled
 - › Last remote loopback request sent – none or deactivate
 - › FDL – status of FDL: standard configured or not configured
 - › FDL Transmit Path – status of path transmission: active or not active
 - › FDL Transmit Idle-Signal – status of idle signal: active or not active
 - › FDL Transmit Test-Signal – status of test signal: active or not active
 - › Equipment Identification Code – eic string for FDL
 - › Line Identification Code – lic string for FDL
 - › Frame Identification Code – fic string for FDL
 - › Unit Identification Code – unit string for FDL
 - › Facility Identification Code – pfi string for FDL
 - › Port Code – port string for FDL
 - › Generator Number – generator string for FDL

- › BERT test – number of current test and total number of tests
 - Test interval – length of the BERT test
 - status – Sync (controller is synchronized with remote device) or NoSync (controller is not synchronized with remote device)
 - Sync count – number of times the pattern detector synchronized with the incoming data pattern
 - Received bit count – number of bits received
 - Error bit count – number of bits with errors
 - › Number of valid intervals – number of 15-minute intervals since the line module was last powered on or reset
 - › Time elapse in current interval – statistics are reported in 15-minute intervals
 - › Errored seconds – number of errored seconds encountered by a T1 in the current interval
 - › Severely errored seconds – number of severely errored seconds encountered by a T1 in the current interval
 - › Severely errored frame seconds – number of severely errored framing seconds encountered by a T1 in the current interval
 - › Unavailable seconds – number of unavailable seconds encountered by a T1 in the current interval
 - › Clock slip seconds – number of clock slips encountered by a T1 in the current interval
 - › Path code violations – number of coding violations encountered by a T1 in the current interval
 - › Line errored seconds – number of line errored seconds encountered by a T1 in the current interval
 - › Bursty errored seconds – number of bursty errored seconds encountered by a T1 in the current interval
 - › Degraded minutes – number of minutes that a T1 line is degraded
 - › Line code violations – number of line code violations encountered by a T1 in the current interval
- Example 1: In this example, a t1 channel and the **brief** keyword is specified.

```
host1>show controllers t3 2/0:1 brief
```

```
DS3 2/0:1
ifOperStatus = ifOperUp
Yellow Alarm detection is active
Yellow Alarm generation is active
snmp trap link-status = disabled
Framing is D4, Line Code is Ami, Clock Source is Internal -
  Module
  Allocated Ds0 time slot map = 0x0
Loopback Enabled - Diagnostic
Last Remote Loopback Request Sent - Deactivate
FDL is not configured
FDL Transmit Path-Id is not active
FDL Transmit Test-Signal is not active
```

```
FDL Transmit Idle-Signal is not active
Equipment Identification Code is the null string
Line Identification Code is the null string
Frame Identification Code is the null string
Unit Identification Code is the null string
Facility Identification Code is the null string
Port Code is the null string
Generator Number is the null string
BERT test - 2 in 23
Test Interval 1 minute(s), Complete
Sync count = 1
Received bit count = 92148912
Error bit count = 17
Number of valid interval - 90
Time elapse in current interval - 580
```

- **Example 2:** In this example, a T1 channel is specified.

```
host1#show controllers t3 1/0:1

DS1 1/0:1
ifOperStatus = ifOperUp
Yellow Alarm detection is active
Yellow Alarm generation is active
snmp trap link-status = disabled
Framing is D4, Line Code is Ami, Clock Source is Internal -
  Module
  Allocated Ds0 time slot map = 0x0
Last Remote Loopback Request Sent - Deactivate
FDL is not configured
FDL Transmit Path-Id is not active
FDL Transmit Test-Signal is not active
FDL Transmit Idle-Signal is not active
Equipment Identification Code is the null string
Line Identification Code is the null string
Frame Identification Code is the null string
Unit Identification Code is the null string
Facility Identification Code is the null string
Port Code is the null string
Generator Number is the null string
BERT test - 2 in 23
Test Interval 1 minute(s), Complete
Sync count = 1
Received bit count = 92148912
Error bit count = 17
Number of valid interval - 90
Time elapse in current interval - 580
```

```
Dsl Current Interval Counters
Errored seconds = 0
Severely errored second = 0
Severely errored frame seconds = 0
Unavailable seconds = 0
Clock slip seconds = 0
Path code violations = 0
Line errored seconds = 0
Bursty errored seconds = 0
Degraded minutes = 0
Line code violations = 0

Dsl Last Interval Counters
Errored seconds = 0
Severely errored second = 0
Severely errored frame seconds = 0
Unavailable seconds = 0
Clock slip seconds = 0
Path code violations = 0
Line errored seconds = 0
Bursty errored seconds = 0
Degraded minutes = 0
Line code violations = 0

Dsl 24 Hour Total Counters
Errored seconds = 25
Severely errored second = 7
Severely errored frame seconds = 25
Unavailable seconds = 0
Clock slip seconds = 6
Path code violations = 18
Line errored seconds = 0
Bursty errored seconds = 0
Degraded minutes = 0
Line code violations = 0
```

show controllers t3 ft1

- Use to display information about the state of a fractional T1 subchannel.
- Field descriptions
 - › ifOperStatus – physical status of the interface
 - ifOperUp – interface is functioning
 - ifOperTesting – interface is being tested
 - ifOperNotPresent – module has been removed from the chassis
 - ifOperDown – interface is not functioning

- › snmp trap link-status of SNMP trapping (enabled or disabled)
- › Ds0 time slot map – fractional T1 subchannel
- › Ds0 mode – base data rate: either Nx56 or Nx64
- The **ft1** option displays the state of the serial interface.
- The optional *slot* and *port* parameters display information on a specific slot and port.
- Example

```
host1>show controllers t3 ft1

Ft1 Interface at 2/0:1/1
ifOperStatus = ifOperLowerLayerDown
snmp trap link-status = disabled
Ds0 time slot map = 0x1
Ds0 mode = Nx64
```

show controllers t3 remote

- Use to display MIB statistics for the remote end of a CT3 interface configured for MDL or for the remote end of a T1 channel configured for FDL.
- Specify the **all** option to display detailed information for all 15-minute intervals.
- For definitions of the MIB statistics for a T3 interface, see RFC 2496 – Definitions of Managed Objects for the DS3/E3 Interface Types (January 1999).
- For definitions of the MIB statistics for a T1 channel, see RFC 2495 – Definitions of Managed Objects for the DS1, E1, DS2 and E2 Interface Types (January 1999).
- Field descriptions for a T3 interface
 - › Far End MDL Carrier bit – status of MDL configuration on remote device connected to T3 interface
 - set – MDL is configured for carrier mode
 - not set – MDL is not configured for carrier mode
 - › Far End Equipment Identification Code – eic string sent by remote device for MDL
 - › Far End Line Identification Code – lic string sent by remote device for MDL
 - › Far End Frame Identification Code – fic string sent by remote device for MDL
 - › Far End Unit Identification Code – unit string sent by remote device for MDL
 - › Far End Facility Identification Code – pfi string sent by remote device for MDL
 - › Far End Generator Number – generator string sent by remote device for MDL
 - › Far End Port Number – port string sent by remote device for MDL
 - › Number of valid intervals – number of 15-minute intervals since the line module was last powered on or reset
 - › Time elapse in current interval – number of seconds that have passed in the 15-minute (900-second) interval

- › C-bit errored seconds – number of C-bit errored seconds encountered by a T3 in the current interval
 - › C-bit severely errored seconds – number of C-bit severely errored seconds encountered by a T3 in the current interval
 - › C-bit coding violations– number of C-bit coding violations encountered by a T3 in the current interval
 - › Unavailable seconds – number of unavailable seconds encountered by a T3 in the current interval
 - › Invalid seconds – number of seconds when statistics were not collected
- Example: In this example, a T3 interface is specified.

```
host1#show controller t3 5/0 remote
```

```
Far End MDL Carrier bit is not set
Far End Equipment Identification Code is the null string
Far End Line Identification Code is the null string
Far End Frame Identification Code is the null string
Far End Unit Identification Code is the null string
Far End Facility Identification Code is the null string
Far End Generator Number is the null string
Far End Port Number is the null string
```

```
Number of valid interval - 3
```

```
Time elapse in current interval - 756
```

```
Ds3 Current Interval Counters
```

```
C-bit errored seconds          = 0
C-bit severely errored seconds = 0
C-bit coding violations         = 0
Unavailable seconds           = 0
Invalid seconds                = 0
```

```
Ds3 Last Interval Counters
```

```
C-bit errored seconds          = 0
C-bit severely errored seconds = 0
C-bit coding violations         = 0
Unavailable seconds           = 0
Invalid seconds                = 0
```

```
Ds3 24 Hour Total Counters
```

```
C-bit errored seconds          = 1
C-bit severely errored seconds = 1
C-bit coding violations         = 330
Unavailable seconds           = 0
Invalid seconds                = 0
```

- Field descriptions for a T1 channel
 - › DS1 – identifier of T1 channel
 - › Number of valid intervals – number of 15-minute intervals since the line module was last powered on or reset
 - › Time elapse in current interval – number of seconds that have passed in the 15-minute (900-second) interval
 - › Far End FDL Carrier bit – status of FDL configuration on remote device connected to T1 channel
 - set – FDL is configured for carrier mode
 - not set – FDL is not configured for carrier mode
 - › Far End Equipment Identification Code – eic string sent by remote device for FDL
 - › Far End Line Identification Code – lic string sent by remote device for FDL
 - › Far End Frame Identification Code – fic string sent by remote device for FDL
 - › Far End Unit Identification Code – unit string sent by remote device for FDL
 - › Far End Facility Identification Code – pfi string sent by remote device for FDL
 - › Far End Generator Number – generator string sent by remote device for FDL
 - › Far End Port Number – port string sent by remote device for FDL
 - › Errored seconds – number of errored seconds encountered by a T1 in the current interval
 - › Severely errored seconds – number of severely errored seconds encountered by a T1 in the current interval
 - › Severely errored frame seconds – number of severely errored framing seconds encountered by a T1 in the current interval
 - › Unavailable seconds – number of unavailable seconds encountered by a T1 in the current interval
 - › Clock slip seconds – number of clock slips encountered by a T1 in the current interval
 - › Path code violations – number of coding violations encountered by a T1 in the current interval
 - › Line errored seconds – number of line errored seconds encountered by a T1 in the current interval
 - › Bursty errored seconds – number of bursty errored seconds encountered by a T1 in the current interval
 - › Degraded minutes – number of minutes that a T1 line is degraded
- Example: In this example, a T1 channel is specified.

```

host1#show controller t3 10/1:1 remote

DS1 10/1:1
Number of valid interval - 0
Time elapse in current interval - 0

```

```
Far End FDL Carrier bit is not set
Far End Equipment Identification Code is the null string
Far End Line Identification Code is the null string
Far End Frame Identification Code is the null string
Far End Unit Identification Code is the null string
Far End Facility Identification Code is the null string
Far End Port Number is the null string
Far End Generator Number is the null string
```

```
DS1 Current Interval Counters
Errored seconds = 0
Severely errored second = 0
Severely errored frame seconds = 0
Unavailable seconds = 0
Clock slip seconds = 0
Path code violations = 0
Line errored seconds = 0
Bursty errored seconds = 0
Degraded minutes = 0
```

```
DS1 24 Hour Total Counters
Errored seconds = 0
Severely errored second = 0
Severely errored frame seconds = 0
Unavailable seconds = 0
Clock slip seconds = 0
Path code violations = 0
Line errored seconds = 0
Bursty errored seconds = 0
Degraded minutes = 0
```

show controllers t3 serial

- Use to display the state of the serial interface.
- Field descriptions
 - › ifOperStatus – physical status of the interface
 - ifOperUp – interface is functioning
 - ifOperTesting – interface is being tested
 - ifOperNotPresent – module has been removed from the chassis
 - ifOperDown – interface is not functioning
 - › snmp trap link-status of SNMP trapping (enabled or disabled)
 - › Crc type checking – size of the CRC (cyclic redundancy check)
 - › Hdlc mru – current size of the maximum receive unit (MRU)

- › Hdlc mtu – current size of the maximum transmission unit (MTU)
- › Hdlc interface speed – current line speed of the interface
- › Ds0 time slot map – T1 subchannel
- › Invert data disabled – status of the data inversion feature
- The optional *slot* and *port* parameters display information on a specific slot and port.
- Use the *slot/port/channel/subchannel* option to display information on a specific interface.
- Example

```
host1>show controllers t3 serial

Serial Interface at 2/0:1/1
ifOperStatus = ifOperLowerLayerDown
snmp trap link-status = disabled
Crc type checking - CRC16
Hdlc mru = 65529
Hdlc mtu = 65529
Hdlc interface speed = 64000
Ds0 time slot map = 0x1
Invert data disabled, Ds0 mode = Nx64

Serial Interface at 2/1:1/1
ifOperStatus = ifOperLowerLayerDown
snmp trap link-status = disabled
Crc type checking - CRC16
Hdlc mru = 65529
Hdlc mtu = 65529
Hdlc interface speed = 64000
Ds0 time slot map = 0x1
Invert data disabled, Ds0 mode = Nx64

Found 2 Serial Interfaces
```

show interfaces serial

- Use to display information about the serial interfaces you specify.
- Field descriptions
 - › Fractional Interface – location of a CT1 or CE1 interface
 - › ifOperStatus – administrative status of the interface
 - ifOperUp – interface is functioning
 - ifOperTesting – interface is being tested
 - ifOperNotPresent – module has been removed from the chassis
 - ifOperDown – interface is not functioning
 - ifOperLowerDown – lower layer in the interface stack is not functioning
 - › snmp trap link-status – enabled or disabled
 - › Encapsulation – layer 2 encapsulation display; options: ppp, frame-relay ietf, mlppp, mlframe-relay ietf, hdlc
 - › Crc type checking – size of the CRC
 - › Hdlc mru – current size of the MRU
 - › Hdlc mtu – current size of the MTU
 - › Hdlc interface speed – current line speed of the interface
 - › Invert data disabled – status of the data inversion feature
 - › Ds0 time slot map – CT1 or CE1 channel group
 - › Ds0 mode – Nx56 or Nx64
 - › 5 minute input rate – data rates based on the traffic received in the last five minutes
 - › 5 minute output rate – data rates based on the traffic sent in the last five minutes
 - › Interface statistics
 - Packets received – number of packets received on the interface
 - Bytes received – number of bytes received on the interface
 - Errored packets received – number of packets with errors received on the interface
 - Packets sent – number of packets sent on the interface
 - Bytes sent – number of bytes sent on the interface
- Errored packets sent – number of packets with errors sent from the interface

- Example 1

```
host1>show interfaces serial 0/1:2 brief
```

```
Serial Interface at 0/1:2  
ifOperStatus = ifOperUp  
snmp trap link-status = disabled  
Encapsulation hdlc  
Crc type checking - CRC16  
Hdlc mru = 1600  
Hdlc mtu = 1600  
Hdlc interface speed = 768000  
Invert data disabled  
Ds0 time slot map = 0xfff  
Ds0 mode = Nx64
```

```
Serial Interface at 13/0:2  
ifOperStatus = ifOperUp  
snmp trap link-status = disabled  
Crc type checking - CRC16  
Hdlc mru = 1600  
Hdlc mtu = 1600  
Hdlc interface speed = 768000  
Invert data disabled  
Ds0 time slot map = 0xfff000  
Ds0 mode = Nx64
```

```
Found 2 Serial Interfaces
```