

Configuring T3 and E3 Interfaces

Use the procedures described in this chapter to configure T3 and E3 interfaces.

Topic	Page
Overview	2-1
References	2-6
Numbering Schemes	2-6
Before You Configure an Interface	2-11
Configuration Tasks	2-11
Configuration Examples	2-19
Monitoring Interfaces	2-20

Overview

Unchannelized T3 (DS3) and E3 interfaces are supported by the following modules:

- E3 ATM line modules and E3 I/O modules (3 port E3 ATM support)
- E3 FRAME line modules and E3 I/O modules (3 port E3 frame support)
- COCX-F3 line modules and E3-12 FRAME I/O modules (12 port E3 frame support)
- T3 ATM line modules and CT3/T3 I/O modules (3 port T3 ATM support)
- OCx/STMx ATM line modules and 4xDS3 ATM I/O modules (4 port T3 ATM support)

- T3 FRAME line modules and CT3/T3 I/O modules (3 port T3 frame support)
- COCX-F3 line modules and CT3/T3 12 I/O modules (12 port T3 frame support)
- CT3/T3-F0 line modules and CT3/T3 12 I/O modules (12 port T3 frame support)

Throughout this chapter, interfaces on modules that provide ATM support are called T3/E3 ATM interfaces. Similarly, interfaces on modules that provide frame (HDLC) support are called T3/E3 frame interfaces.

T3/E3 ATM Line Modules and Associated I/O Modules

The ERX-700 series and the ERX-1410 system support the T3/E3 ATM line modules and associated I/O modules. The ERX-1440 system does not support these modules.

The ERX-1410 system supports up to twelve T3/E3 ATM line modules and twelve corresponding I/O modules; the ERX-700 series supports up to five of these line modules and five corresponding I/O modules. There are three physical T3/E3 (DS3) ports per I/O module. Each port uses two BNC connectors: one for the transmit (TX) connection and one for the receive (RX) connection.

T3/E3 ATM line modules and associated I/O modules support the following:

- Clocking
- Redundancy
- Frame Relay logical interface support
- Unique IP interface support for each PPP or Frame Relay PVC interface
- Up to 4095 PVCs per T3 or E3 controller and a total of 4095 PVCs per T3/E3 module
- Line speeds of 45 Mbps (T3) and 34 Mbps (E3)

T3/E3 FRAME Line Modules and Associated I/O Modules

The ERX-700 series and the ERX-1410 system support the T3/E3 FRAME line modules and associated I/O modules. The ERX-1440 system does not support these modules.

The ERX-1410 system supports up to twelve T3/E3 FRAME line modules and twelve corresponding I/O modules; the ERX-700 series supports up to five of these line modules and five corresponding I/O modules. There are three physical T3/E3 (DS3) ports per I/O module. Each port uses two BNC connectors: one for the transmit (TX) connection and one for the receive (RX) connection.

T3/E3 FRAME line modules and associated I/O modules support the following:

- Clocking
- Redundancy
- Frame Relay logical interface support
- Unique IP interface support for each PPP or Frame Relay PVC interface
- Line speeds of 45 Mbps (T3) and 34 Mbps (E3)
- HDLC
- Fractional T3 (T3 only)

COCX-F3 Line Modules and Associated I/O Modules

Both the ERX-700 series and the ERX-1400 series support the COCX-F3 line modules and associated I/O modules.

The ERX-1400 series supports up to twelve COCX-F3 line modules and twelve corresponding I/O modules; the ERX-700 series supports up to five of these line modules and five corresponding I/O modules. There are twelve physical T3/E3 (DS3) ports per I/O module. Each port uses two SMB connectors: one for the transmit (TX) connection and one for the receive (RX) connection.

COCX-F3 line modules and associated I/O modules support the following:

- Clocking
- Redundancy
- Frame Relay logical interface support

- Unique IP interface support for each PPP or Frame Relay PVC interface
- HDLC
- Fractional T3 (T3 only)
- Line speeds of 45 Mbps (T3) and 34 Mbps (E3)

OCx/STMx ATM Line Modules and 4xDS3 ATM I/O Modules

The ERX-700 series and the ERX-1400 series support the OCx/STMx ATM line modules and 4xDS3 ATM I/O modules.

The ERX-1400 series supports up to twelve OCx/STMx ATM line modules and twelve 4xDS3 ATM I/O modules; the ERX-700 series supports up to five of these line modules and five corresponding I/O modules. There are four physical T3 (DS3) ports per I/O module. Each port uses two BNC connectors: one for the transmit (TX) connection and one for the receive (RX) connection.

OCx/STMx ATM line modules pair with 4xDS3 ATM I/O modules to support the following:

- Clocking
- Redundancy
- Frame Relay logical interface support
- Unique IP interface support for each PPP or Frame Relay PVC interface
- Line speeds of 45 Mbps

CT3/T3-F0 Line Modules and CT3/T3 12 I/O Modules

The ERX-700 series and the ERX-1400 series support the CT3/T3-F0 line modules and CT3/T3 12 I/O modules. The CT3/T3-F0 line module and CT3/T3 12 I/O module support both channelized and unchannelized T3 operation. You can configure a mixture of channelized and unchannelized ports on these modules. To configure these modules to support unchannelized T3 operation, issue the **no channelized** command. (See *Configuration Tasks*, later in this chapter). For information about configuring channelized T3 ports, see *Chapter 1, Configuring Channelized T3 Interfaces*.

The ERX-1400 series supports up to twelve CT3/T3-F0 line modules and twelve CT3/T3 12 I/O modules; the ERX-700 series supports up to five of these line modules and five corresponding I/O modules. There are twelve

physical T3 (DS3) ports per I/O module. Each port uses two SMB connectors: one for the transmit (TX) connection and one for the receive (RX) connection.

CT3/T3-F0 line modules and CT3/T3 12 I/O I/O modules to support the following:

- Clocking
- Redundancy
- Frame Relay logical interface support
- Unique IP interface support for each PPP or Frame Relay PVC interface
- Line speeds of 45 Mbps

Interface Stack

Figure 2-1 shows the stack for T3 ATM and E3 ATM interfaces. Figure 2-2 shows the stack for T3 frame and E3 frame interfaces.

To configure a T3 ATM or E3 ATM interface, first configure a T3 or E3 controller. To configure ATM parameters, see *Chapter 10, Configuring ATM*.

To configure a T3 frame or E3 frame interface, first configure a T3 or E3 controller, and then configure a High-Speed Data Link Control (HDLC) data channel on the controller.

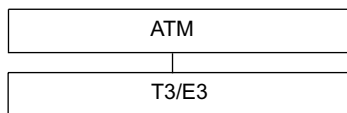

Figure 2-1 Stack for T3 ATM and E3 ATM interfaces

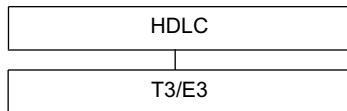

Figure 2-2 Stack for T3 frame and E3 frame interfaces



Note: For a detailed discussion of interface types and specifiers, see the *ERX Command Reference Guide, About This Guide*. For a discussion about interfaces, see *System Basics Configuration Guide, Chapter 1, Planning Your Network*.

MDL Support

T3 interfaces on some line modules support maintenance data link (MDL) messages. For a list of the line modules that support MDL, see the *Release Notes*.

You can configure T3 interfaces to send MDL messages that comply with ANSI T1.107a-1990 Standard for Telecommunications – Digital Hierarchy – Supplement to Formats Specification (August 1990). MDL messages identify a particular link by sharing common codes for data such as the equipment identifier, line identifier, frame identifier, and unit.

You can use MDL messages to determine the status of a link and to display statistics for the remote end of a connection. MDL messages do not interfere with other data transmitted over the link.

Higher-Level Protocols

See the release notes for information about the higher-level protocols that T3 and E3 interfaces support.

References

The T3 and E3 meet the following specifications:

- RFC 1661 – The Point-to-Point Protocol (PPP) (July 1994)
- RFC 2364 – PPP over AAL5 (July 1998)
- RFC 2496 – Definitions of Managed Objects for the DS3/E3 Interface Types (January 1999)
- RFC 2516 – Method for Transmitting PPP over Ethernet (PPPoE) (February 1998)
- RFC 2684 – Multiprotocol Encapsulation over ATM Adaptation Layer 5 (September 1999)
- ANSI T1.107a-1990 Standard for Telecommunications – Digital Hierarchy – Supplement to Formats Specification (August 1990)

Numbering Schemes

This section describes how to identify T3 and E3 interfaces.

T3 Controllers

A T3/E3 controller on a T3/E3 ATM or frame interface is identified using the *slot/port* format, where:

- *slot* – number of the slot in which the line module resides in the chassis. In the ERX-700 series, line module slots are numbered 2-6 (slots 0 and 1 are reserved for SRP modules). In the ERX-1400 series, line module slots are numbered 0-5 and 8-13 (slots 6 and 7 are reserved for SRP modules).
- *port* – number of the port on the I/O module. On the CT3/T3 and E3 I/O modules, ports are numbered 0-2; on the CT3/T3 12 I/O and E3-12 FRAME I/O modules, ports are numbered 0-11.

For T3 examples, see the following figures. The E3 modules are very similar in appearance to the equivalent T3 modules.

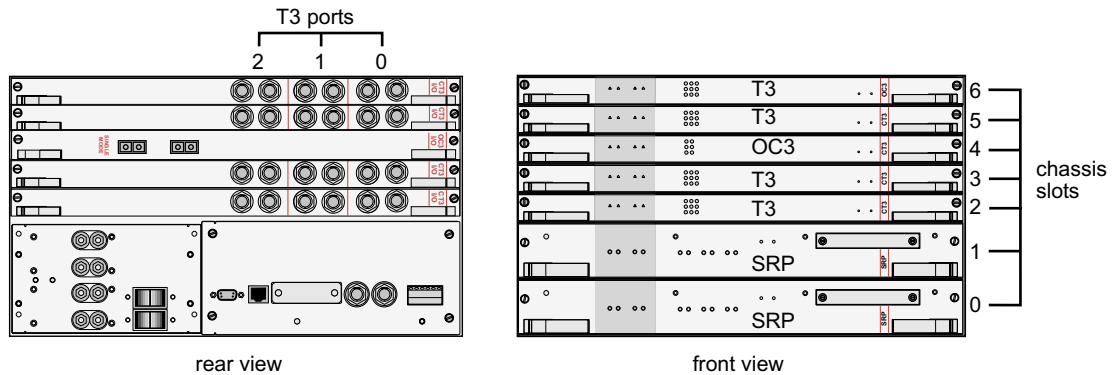

Figure 2-3 T3 line modules and CT3/T3 I/O modules in ERX-700 series

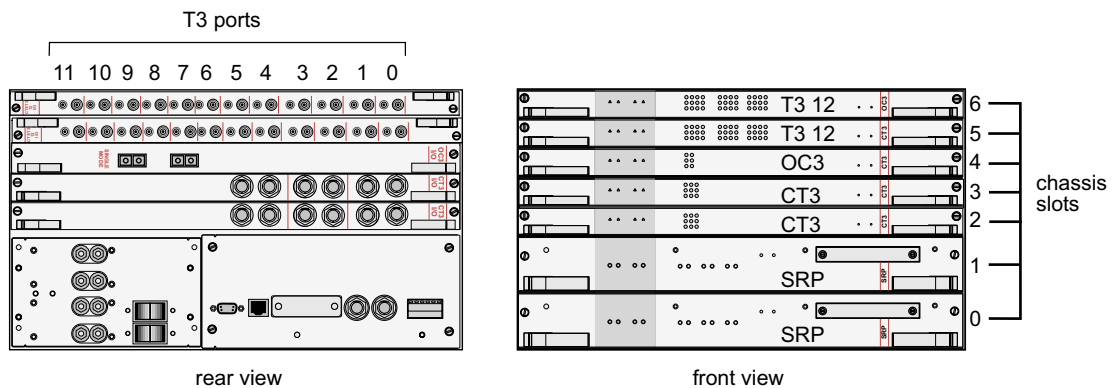

Figure 2-4 COCX-F3 line modules and CT3/T3 12 I/O modules in the ERX-700 series

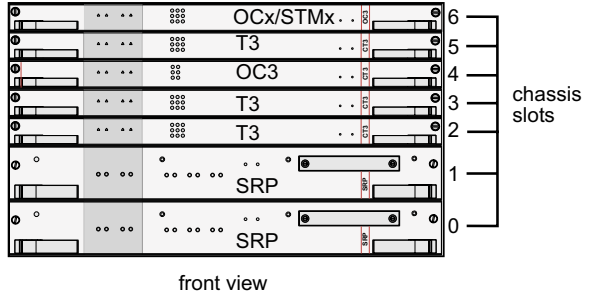
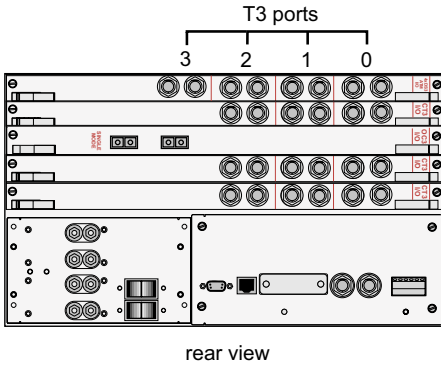

Figure 2-5 OCx/STMx ATM line module and 4xDS3 ATM I/O module in ERX-700 series

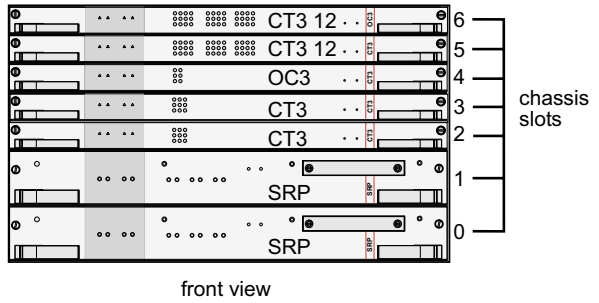
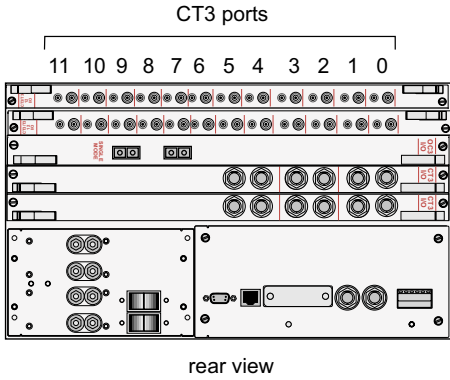

Figure 2-6 CT3/T3-F0 line modules and CT3/T3 12 I/O modules in the ERX-700 series

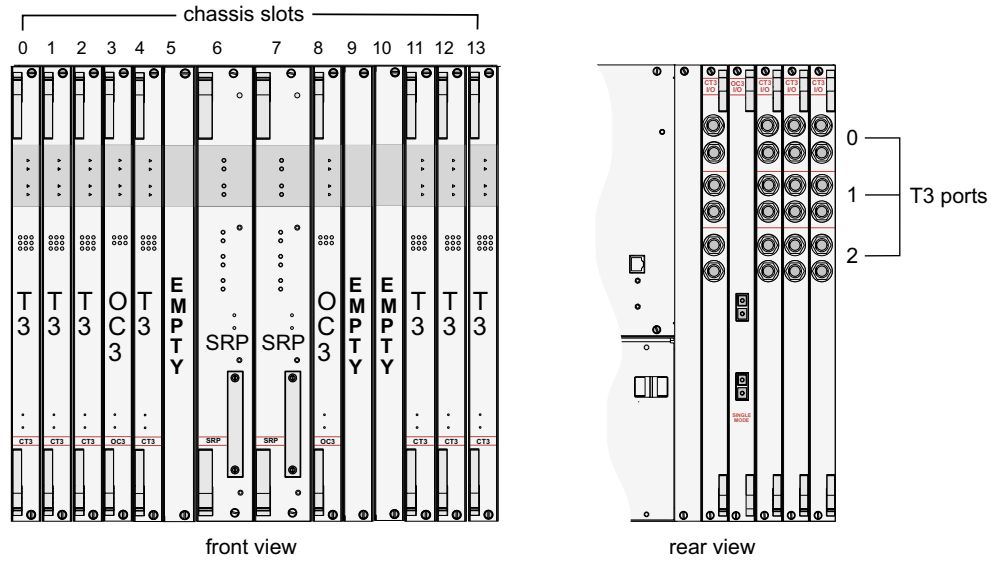

Figure 2-7 T3 line modules and CT3/T3 I/O modules in ERX-1410 system

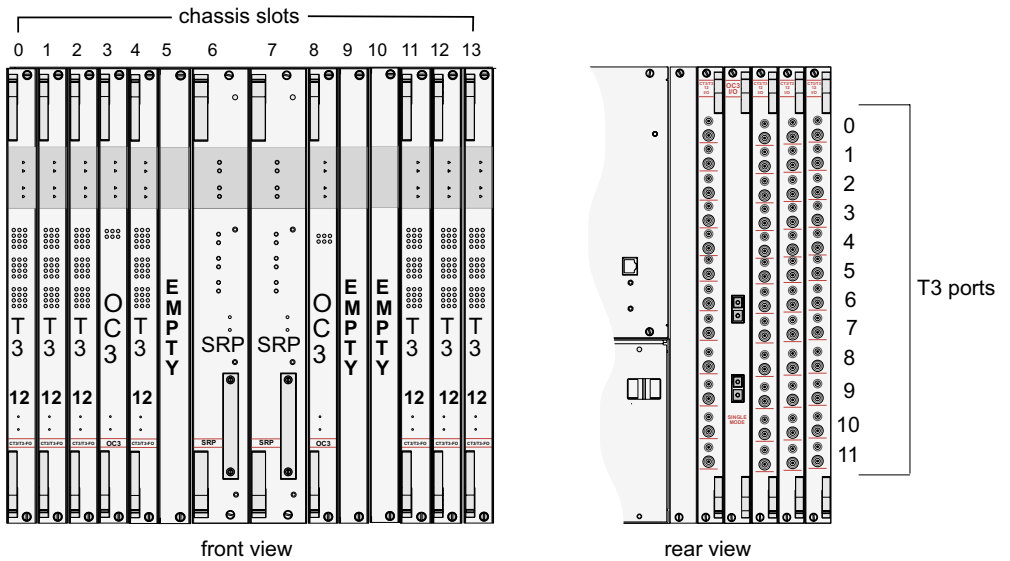

Figure 2-8 COCX-F3 line modules and CT3/T3 12 I/O modules in ERX-1400 series

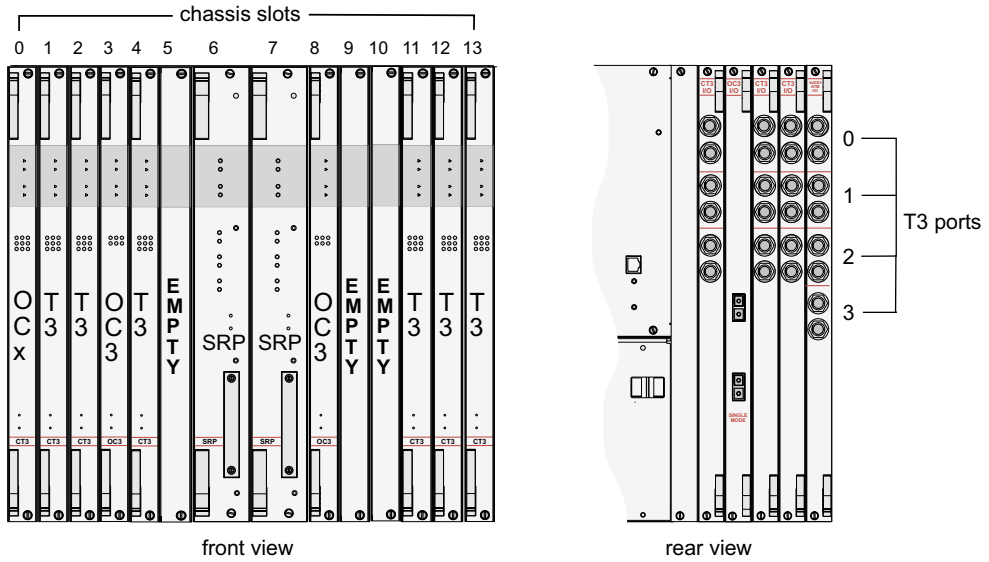

Figure 2-9 OCx/STMx ATM line module and 4xDS3 ATM I/O module in ERX-1400 series

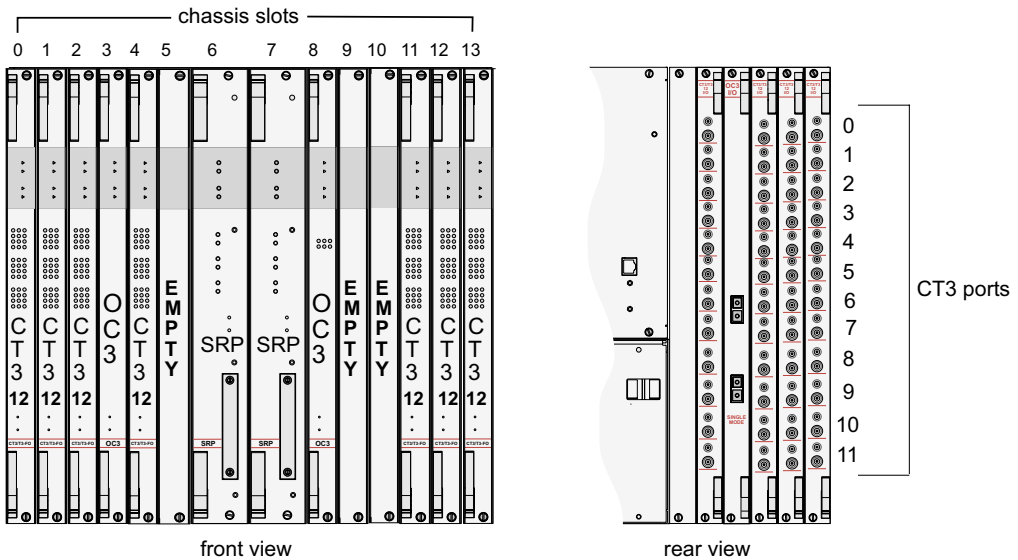

Figure 2-10 CT3/T3-F0 line modules and CT3/T3 12 I/O modules in ERX-1400 series

Before You Configure an Interface

Before you configure a T3 or an E3 interface, verify that you have installed the line modules and I/O modules correctly.

You need the following information for each T3 controller:

- Framing type
- Clock source
- Cable length

You also need HDLC channel information, such as data inversion information, for interfaces that will support HDLC.

Configuration Tasks

Configure a T3 interface by entering Global Configuration mode and performing the following tasks:

- 1 Configure a T3 controller.
- 2 (Optional) Configure MDL settings.
- 3 (Optional) Configure other settings for the interface.
- 4 Configure HDLC channels for T3 frame and E3 frame controllers.
- 5 (Optional) Configure fractional T3 for T3 frame controllers.
- 6 Use the appropriate **show** commands to verify your configuration.

E3 interface configuration tasks are identical to T3 interface configuration tasks, except that the CLI commands contain **e3** instead of **t3**.

For example, you configure an E3 controller with the **controller e3** command instead of the **controller t3** command.

Configuring a T3 or an E3 Controller

To configure a T3 or an E3 controller, complete the following tasks.

- 1 Select the T3 or E3 controller from Global Configuration mode.

```
host1(config)#controller t3 3/2
```

- 2 Enable the T3 or E3 controller.

```
host1(config-controller)#no shutdown
```

- 3 (CT3/T3-F0 line module only) Enable unchannelized operation for this controller.

```
host1(config-controll)#no channelized
```

channelized

- Use to enable channelized T3 operation on an interface of an CT3/T3-F0 line module.

- Example

```
host1(config-controll)#channelized
```

- Use the **no** version to enable unchannelized T3 operation on an interface for a CT3/T3-F0 line module.

controller e3

- Use to specify a E3 controller in *slot/port* format.
 - › *slot* – number of the slot in which the line module resides in the chassis
 - › *port* – number of the port on the I/O module

- Example

```
host1(config)#controller e3 3/2
```

- There is no **no** version.

controller t3

- Use to specify a T3 controller in *slot/port* format.
 - › *slot* – number of the slot in which the line module resides in the chassis
 - › *port* – number of the port on the I/O module

- Example

```
host1(config)#controller t3 0/1
```

- There is no **no** version.

shutdown

- Use to disable a T3 or E3 controller.
- The T3 or E3 interface is disabled by default.
- Example

```
host1(config-controll)#shutdown
```

- Use the **no** version to restart a disabled interface.

Configuring MDL Messages

You can configure a CT3 interface to send MDL messages. MDL messages are supported only when T3 framing uses C-bit parity, the default setting.

To configure a CT3 interface to send MDL messages:

- 1 Specify a T3 interface.

```
host1(config)#controller t3 8/0
```

- 2 (Optional) Configure the interface to operate in an MDL carrier environment.

```
host1(config-controller)#mdl carrier
```

- 3 Specify the MDL messages.

```
host1(config-controller)#mdl string eic "ERX-1400"  
host1(config-controller)#mdl string fic "FG786"  
host1(config-controller)#mdl string lic "Bldg 10"  
host1(config-controller)#mdl string pfi "Site 25"  
host1(config-controller)#mdl string port 0800
```

- 4 Enable transmission of MDL messages.

```
host1(config-controller)#mdl transmit path-id  
host1(config-controller)#mdl transmit idle-signal  
host1(config-controller)#mdl transmit test-signal
```

mdl carrier

- Use to specify that an interface is used in the carrier environment.
- Example

```
host1(config-controller)#mdl carrier
```
- Use the **no** version to restore the default situation, in which the interface does not operate in the carrier environment.

mdl string

- Use to specify an MDL message.
- Example

```
host1(config-controller)#mdl string port 0800
```
- Use the **no** version to restore the default value to the specified MDL message or to all MDL messages.

mdl transmit

- Use to enable transmission of MDL messages.
- Specify the keyword **path-id** to transmit path identifications every second.
- Specify the keyword **idle-signal** to send idle signals every 10 seconds.
- Specify the keyword **test-signal** to transmit test signals every 10 seconds.
- Example

```
host1(config-controller)#mdl transmit test-signal
```
- Use the **no** version to disable transmission of the specified MDL message or all MDL messages.

Optional Tasks

The following configuration tasks are optional for T3 and E3 interfaces:

- Specify the cable length (T3 only).
- Change the clock source.
- Change the framing format.
- Enable cell scrambling (ATM interfaces only).

cablelength

- Use to adjust the transmit power appropriate to the length of a T3 cable.
- Specify a cable length in the range 1–450 feet.
- The system supports two transmit powers, one for a cable length between 1–225 feet and another for a cable length between 226–450 feet. Therefore, it is not necessary to know the exact size of your cable. You only need to know if the cable size is greater than 225 feet. For example, if your cable size is over 225 feet, specify any number greater than 225 and less than 451.
- Example

```
host1(config-controll)#cablelength 300
```
- Use the **no** version to restore the default, 0 feet.

clock source

- Use to configure the transmit clock source for a T3 or E3 line.
- Use a transmit clock on the line's receive data stream, except in rare cases such as back-to-back router tests. When performing back-to-back router tests, configure one end of the line as **internal** and the other end as **line**.
- Specify the keyword **line** to use a transmit clock on the line's receive data stream.
- Specify the keywords **internal module** to use the line module's internal clock.
- Specify the keywords **internal chassis** to use the system's clock.
- Example

```
host1(config-controll)#clock source internal module
```
- Use the **no** version to revert to the default, **line**.

ds3-scramble

- Use to enable cell scrambling in a T3 ATM interface.
- Example

```
host1(config-controll)#ds3-scramble
```
- Use the **no** version to turn off cell scrambling on the interface.

e3-scramble

- Use to enable cell scrambling in an E3 ATM interface.
- Example

```
host1(config-controll)#e3-scramble
```
- Use the **no** version to turn off cell scrambling on the interface.

framing

- Use to configure the framing format for a T3 or E3 line.
- For a T3 line, you must specify one of the following:
 - › T3 FRAME – **c-bit** or **m23** (the default is **c-bit**)
 - › T3 ATM – **cbitadm**, **cbitplcp**, **m23adm**, or **M23plcp** (the default is **cbitplcp**)
- For an E3 line, you must specify one of the following:
 - › E3 FRAME – **g751** or **g832** (the default is **g751**)
 - › E3 ATM – **g751adm**, **g751plcp**, or **g832adm** (the default is **g751plcp**)
- Choose a framing format that is compatible with the framing format of the Telco network device at the other end of the line.
- Example

```
host1(config-controll)#framing m23
```
- Use the **no** version to restore the default value.

Testing a T3 or an E3 Line

If you are testing the T3 or E3 line, use the **clock source** and **loopback** commands from the Controller Configuration mode.

- 1 Change the clock source to internal.
- 2 Specify a loopback.

loopback

- Use to configure a loopback.
- Specify one of the following options.
 - › **local** loopback loops the data back toward the router and sends an alarm indication signal (AIS) out toward the network.
 - › **network** loopback loops the data toward the network before the data reaches the frame.
 - › **payload** loopback loops the data toward the network after the framer has processed the data.
- Example

```
host1(config-controll)#loopback local
```
- Use the **no** version to restore the default situation, no loopback.

Configuring Fractional T3

You can configure fractional T3 on T3 frame interfaces. E3 frame interfaces do not support fractional E3.

Fractional T3 is a portion of a T3 transmission service and provides a set of lines with a speed that is greater than T1 (1.544 Mbps), but less than T3 (44.736 Mbps). To configure fractional T3, complete the following steps:

- 1 Set the DSU mode for the lines.
- 2 Set the speed of the fractional T3 lines.
- 3 Enable scrambling of the payload.



Caution: Complete all three steps at the same time. Otherwise, the interface may drop packets unexpectedly.

dsu bandwidth

- Use to set the speed for the fractional T3 lines.
- If you issue this command, be sure to issue the **dsu mode** and **scramble** commands. Otherwise, the interface may drop packets unexpectedly.
- The system offers a set of speeds in increments that depend on the DSU mode you specify. The actual speed of the fractional T3 lines will be the value closest to the fractional bandwidth you specify.
- Example

```
host1(config-controll)#dsu bandwidth 10000
```
- Use the **no** version to clear the bandwidth.
- If you issue the **no** version, be sure to issue the **no dsu mode** and **no scramble** commands. Otherwise, the interface may drop packets unexpectedly.

dsu mode

- Use to set the DSU mode for the lines.
- Specify 0 for Digital Link mode or 2 for Larscom mode.
- If you issue this command, be sure to issue the **dsu bandwidth** and **scramble** commands. Otherwise, the interface may drop packets unexpectedly.
- Example

```
host1(config-controll)#dsu mode 0
```
- Use the **no** version to clear the DSU mode.
- If you issue the **no** version, be sure to issue the **no dsu bandwidth** and **no scramble** commands. Otherwise, the interface may drop packets unexpectedly.

scramble

- Use to enable cell scrambling on a T3 frame interface.

- If you issue this command, be sure to issue the **dsu mode** and **dsu bandwidth** commands. Otherwise, the interface may drop packets unexpectedly.
- Example

```
host1(config-controll)#scramble
```
- Use the **no** version to turn off cell scrambling on the interface.
- If you issue the **no** version, be sure to issue the **no dsu mode** and **no dsu bandwidth** commands. Otherwise, the interface may drop packets unexpectedly.

Configuring an HDLC Channel

You must configure an HDLC channel for each T3 frame or E3 frame controller.

To configure an HDLC channel, configure a serial interface (for example, HDLC channel in slot 0, 1).

```
host1(config)#interface serial 0/1
```

Optional Tasks

The following configuration tasks are optional when you configure an HDLC channel on a T3/E3 frame interface:

- Configure the cyclic redundancy check (CRC).
- Enable data inversion on the interface.
- Set the time interval for monitoring bit and packet rates.
- Set the maximum receive unit (MRU).
- Set the maximum transmit unit (MTU).

crc

- Use to configure the size of the CRC.
- Specify the number of bits per frame (16 or 32) that are used to calculate the frame check sequence (FCS). Both the sender and receiver must use the same setting.
- The CRC is an error-checking technique that uses a calculated numeric value to detect errors in transmitted data.
- A 32-bit CRC should be used to protect longer streams at faster rates and, therefore, provide better ongoing error detection.
- Example

```
host1(config-if)#crc 32
```
- Use the **no** version to restore the default value, 16.

interface serial

- Use to configure a serial interface in the *slot/port* format.
 - › *slot* – number of the slot in which the line module resides in the chassis
 - › *port* – number of the port on the I/O module
- Example

```
host1(config)#interface serial 3/0
```
- Use the **no** version to disable the interface.

invert data

- Use to enable data stream inversion for the interface.
- Enable data stream inversion only if it is turned on at the other end of the line.
- Example

```
host1(config-if)#invert data
```
- Use the **no** version to disable the feature.

load-interval

- Use to set the time interval at which the system calculates bit and packet rate counters.
- Choose a multiple of 30 seconds, in the range 30–300 seconds.
- Example

```
host1(config-if)#load-interval 100
```
- Use the **no** version to restore the default value, 300 seconds.

mrp

- Use to configure the MRU size for the interface.
- Coordinate this value with the network administrator on the other end of the line.
- If you set this parameter to a different value for another protocol, such as IP, the system uses the lower value. This could produce unexpected behavior in your network.
- Example

```
host1(config-if)#mrp 1500
```
- Use the **no** version to restore the default, 1600 bytes.

mtu

- Use to configure the MTU size for the interface.
- Coordinate this value with the network administrator on the other end of the line.
- If you set this parameter to a different value for another protocol, such as IP, the system uses the lower value. This could produce unexpected behavior in your network.
- Example

```
host1(config-if)#mtu 1500
```
- Use the **no** version to restore the default, 1600 bytes.

Configuration Examples

To configure a T3 interface, start at the Global Configuration mode, and enter the following commands:

```
host1(config)#controller t3 0/1
host1(config-controll)#no shutdwon
host1(config-controll)#framing c-bit
host1(config-controll)#clock source internal module
host1(config-controll)#cablelength 220
host1#exit
```

To configure an E3 interface, use the **controller e3** command in place of the **controller t3** command.

To configure HDLC channels on a T3 serial interface, enter the following commands:

```
host1(config)#controller t3 10/0
host1(config-controll)#exit
host1(config)#interface serial 10/0
host1(config-subif)#encapsulation ppp
host1(config-subif)#ip address 192.32.10.2 255.255.255.0
```

To configure fractional T3 on an interface, enter the following commands:

```
host1(config)#controller t3 10/0
host1(config-controll)#dsu mode 0
host1(config-controll)#dsu bandwidth 10000
host1(config-controll)#scramble
```

Monitoring Interfaces

From User Exec mode, use the following **show** commands to monitor and display the T3 or E3 interface information:

```
host1>show controllers t3 0/1
```

```
host1>show controllers e3 3/2
```

Setting a Baseline

You can set a statistics baseline for serial interfaces using the **baseline interface serial** command. Use the **delta** keyword with the **show** commands to display statistics with the baseline subtracted.

Displaying Counters and Time Intervals

Counters and time intervals are MIB statistics, which are defined in RFC 2496 – Definitions of Managed Objects for the DS3/E3 Interface Types (January 1999).

The **show controllers t3 slot/port all** command displays the following interface information:

- Status information
- T3 current interval counters – displays the counters for the current interval
- T3 last interval counters – displays the counters for the previous interval
- T3 24-hour total counters – displays the cumulative counters for the last 24-hours or since the interface was started
- The last 24-hours of 15-minute reporting intervals (96 intervals)

The **show controllers e3 slot/port all** command displays identical information for an E3 controller (except where noted).

Output Filtering

You can use the output filtering feature of the **show** command to include or exclude lines of output based on a text string you specify. See *ERX System Basics Configuration Guide, Chapter 2, Command Line Interface*, for details.

baseline interface serial

- Use to set a statistics baseline for serial interfaces.
- The system implements the baseline by reading and storing the statistics at the time the baseline is set and then subtracting this baseline whenever baseline-relative statistics are retrieved.
- Use the optional **delta** keyword with the **show interfaces serial** commands to view the baseline statistics.
- Example

```
host1#baseline interface serial 2/0
```
- There is no **no** version.

show controllers t3 **show controllers e3**

- Use to display the parameters and MIB statistics on an interface.
- For definitions of the MIB statistics, see RFC 2496 – Definitions of Managed Objects for the DS3/E3 Interface Types (January 1999)
- Field descriptions
 - › ifAdminStatus – one of the following administrative states of the interface:
 - ifAdminUp – interface is administratively enabled
 - ifAdminDown – interface is administratively disabled
 - ifAdminTesting – interface is administratively configured in a testing state
 - › snmp trap link-status – status of snmp trapping (enabled or disabled)
 - › alarms detected – one of the following T3 alarms (not applicable for E3):
 - No alarm present – no alarms present on the line
 - Rcv RAI Failure– remote device is sending a far end alarm failure
 - Xmt RAI Failure – local device is sending a far end alarm failure
 - Rcv AIS – remote device is sending an alarm indication signal (AIS)
 - Xmt AIS – local device is sending an AIS
 - Rcv LOF – loss of one or more frames from the remote end
 - Rcv LOS – loss of signal at the local end



Note: The *alarms detected* field does not appear for interfaces that you disabled in the software.

- › framing – type of framing format
- › line code – type of line code format
- › clock source – type of clock source
- › cable length – cable length in feet (this field is not present for E3 controllers)
- › Loopback – state of loopback for the controller: enabled or disabled. If loopback is enabled, one of the following states is displayed:
 - Diagnostic – data loops back toward the router and sends an alarm AIS toward the network
 - Payload – data loops toward the network after the framer has processed the data
 - Line – data loops toward the network before the data reaches the framer

- › loopback state – state of loopback for the controller: enabled or disabled
- › DSU mode – mode of the fractional T3 lines: Digital Link mode or Larscom mode
- › DSU bandwidth – speed of the fractional T3 lines
- › DSU scramble – status of scrambling for fractional T3: on or off
- › MDL Transmit Path – indicates whether the transmission is active or not active (T3 only)
- › MDL Transmit Test-Signal – indicates if the transmission is active or not active (T3 only)
- › MDL Transmit Idle-Signal – indicates if the transmission is active or not active (T3 only)
- › Equipment Identification Code – eic string for MDL (T3 only)
- › Line Identification Code – lic string for MDL (T3 only)
- › Frame Identification Code – fic string for MDL (T3 only)
- › Facility Identification Code – fic string for MDL (T3 only)
- › Equipment Port – port string for MDL (T3 only)
- › Unit Identification Code – unit string for MDL (T3 only)
- › Facility Identification Code – pfi string for MDL (T3 only)
- › Port Code – port string for MDL (T3 only)
- › Generator Number – generator string for MDL (T3 only)
- › Number of valid intervals – number of 15-minute intervals since the T3 or E3 module was last powered on or reset
- › Time elapse in current interval – number of seconds that have passed in the 15-minute (900 second) interval
- › Errored seconds – number of errored seconds encountered by an E3 (not applicable for T3) in the current interval (this field is not present for T3 controllers)
- › P-bit errored seconds – number of errored seconds encountered by a T3 (not applicable for E3) in the current interval (this field is not present for E3 controllers)
- › Severely errored seconds – number of severely errored seconds encountered by an E3 (not applicable for T3) in the current interval (this field is not present for T3 controllers)
- › P-bit severely errored seconds – number of severely errored seconds encountered by a T3 (not applicable for E3) in the current interval (this field is not present for E3 controllers)
- › Severely errored frame seconds – number of severely errored framing seconds encountered by a T3 or E3 in the current interval
- › Unavailable seconds – number of unavailable seconds encountered by a T3 or E3 in the current interval
- › Line code violations – number of line code violations encountered by a T3 or E3 in the current interval
- › P-bit coding violations – number of coding violations encountered by a T3 (not applicable for E3) in the current interval (this field is not present for E3 controllers)

- › Coding violations – number of coding violations encountered by an E3 (not applicable for T3) in the current interval (this field is not present for T3 controllers)
 - › Line errored seconds – number of line errored seconds encountered by a T3 or E3 in the current interval
 - › C-bit coding violations – number of C-bit coding violations encountered by a T3 (not applicable for E3) in the current interval (this field is not present for E3 controllers)
 - › C-bit errored seconds – number of C-bit errored seconds encountered by a T3 (not applicable for E3) in the current interval (this field is not present for E3 controllers)
 - › C-bit severely errored seconds – number of C-bit severely errored seconds encountered by a T3 (not applicable for E3) in the current interval (this field is not present for E3 controllers)
- Example

```
host1#show controllers t3 2/0
DS3 2/0
ifAdminStatus = ifAdminDown
snmp trap link-status = enabled
No alarms detected
Framing is C-BIT, Line Code is B3ZS, Clock Source is Line
Cable Length is 0 ft
Loopback Disabled
DSU Mode is Larscom
DSU Bandwidth is 4000
DSU Scrambler is off
MDL Transmit Path is not active
MDL Transmit Test-Signal is active
MDL Transmit Idle-Signal is not active
Equipment Identification Code is ERX-1400
Line Identification Code is Bldg 10
Frame Identification Code is null string
Unit Identification Code is 080001
Facility Identification Code is Site 25
Port Code is Port 0800
Generator Number is null string

Number of valid interval - 96
Time elapse in current interval - 861

Ds3 Current Interval Counters
P-bit errored seconds          = 0
P-bit severely errored seconds = 0
Severely errored frame seconds = 0
Unavailable seconds           = 0
Line code violations           = 0
```

```
P-bit coding violations           = 0
Line errored seconds             = 0
C-bit coding violations           = 0
C-bit errored seconds            = 0
C-bit severely errored seconds   = 0
```

```
Ds3 Last Interval Counters
P-bit errored seconds            = 0
P-bit severely errored seconds   = 0
Severely errored frame seconds   = 0
Unavailable seconds              = 0
Line code violations             = 0
P-bit coding violations           = 0
Line errored seconds             = 0
C-bit coding violations           = 0
C-bit errored seconds            = 0
C-bit severely errored seconds   = 0
```

```
Ds3 24 Hour Total Counters
P-bit errored seconds            = 0
P-bit severely errored seconds   = 0
Severely errored frame seconds   = 0
Unavailable seconds              = 0
Line code violations             = 0
P-bit coding violations           = 0
Line errored seconds             = 0
C-bit coding violations           = 0
C-bit errored seconds            = 0
C-bit severely errored seconds   = 0
```

show controllers t3 remote

- Use to display MIB statistics for the remote end of a T3 interface configured for MDL.
- Specify the **all** option to display detailed information for all 15-minute intervals.
- For definitions of the MIB statistics for a T3 interface, see RFC 2496 – Definitions of Managed Objects for the DS3/E3 Interface Types (January 1999).
- Field descriptions
 - › Far End MDL Carrier bit – status of MDL configuration on remote device connected to T3 interface
 - set – MDL is configured for carrier mode
 - not set – MDL is not configured for carrier mode
 - › Far End Equipment Identification Code – eic string sent by remote device for MDL
 - › Far End Line Identification Code – lic string sent by remote device for MDL
 - › Far End Frame Identification Code – fic string sent by remote device for MDL
 - › Far End Unit Identification Code – unit string sent by remote device for MDL

- › Far End Facility Identification Code – pfi string sent by remote device for MDL
 - › Far End Generator Number – generator string sent by remote device for MDL
 - › Far End Port Number – port string sent by remote device for MDL
 - › Number of valid intervals – number of 15-minute intervals since the line module was last powered on or reset
 - › Time elapse in current interval – number of seconds that have passed in the 15-minute (900-second) interval
 - › C-bit errored seconds – number of C-bit errored seconds encountered by a T3 in the current interval
 - › C-bit severely errored seconds – number of C-bit severely errored seconds encountered by a T3 in the current interval
 - › C-bit coding violations– number of C-bit coding violations encountered by a T3 in the current interval
 - › Unavailable seconds – number of unavailable seconds encountered by a T3 in the current interval
 - › Invalid seconds – number of seconds when statistics were not collected
- Example: In this example, a T3 interface is specified.

```
host1#show controller t3 5/0 remote
```

```
Far End MDL Carrier bit is not set
Far End Equipment Identification Code is the null string
Far End Line Identification Code is the null string
Far End Frame Identification Code is the null string
Far End Unit Identification Code is the null string
Far End Facility Identification Code is the null string
Far End Generator Number is the null string
Far End Port Number is the null string
```

```
Number of valid interval - 3
Time elapse in current interval - 756
```

```
Ds3 Current Interval Counters
C-bit errored seconds          = 0
C-bit severely errored seconds = 0
C-bit coding violations        = 0
Unavailable seconds           = 0
Invalid seconds                = 0
```

```
Ds3 Last Interval Counters
C-bit errored seconds           = 0
C-bit severely errored seconds = 0
C-bit coding violations         = 0
Unavailable seconds            = 0
Invalid seconds                 = 0
```

```
Ds3 24 Hour Total Counters
C-bit errored seconds           = 1
C-bit severely errored seconds = 1
C-bit coding violations         = 330
Unavailable seconds            = 0
Invalid seconds                 = 0
```