

Configuring Dynamic Interfaces

This chapter provides a conceptual understanding of dynamic interfaces and the procedures for configuring them in your ERX system.

| Topic | Page |
|---|-------|
| Overview | 21-1 |
| References | 21-3 |
| About Configuring ATM for Dynamic Interfaces | 21-4 |
| About Configuring RADIUS for Dynamic Interfaces | 21-5 |
| Configuring PPP and PPPoE Dynamic Interfaces | 21-6 |
| Configuring PPPoE Dynamic Interfaces over Static PPPoE Interfaces | 21-10 |
| Configuring IPoA Dynamic Interfaces | 21-15 |
| Configuring Bridged Ethernet Dynamic Interfaces | 21-18 |
| Configuring a Dynamic Interface from a Profile | 21-22 |
| Monitoring Dynamic Interfaces and Profiles | 21-37 |
| Scripts and Macros | 21-40 |

Overview

The ERX system software currently supports the following types of dynamic interfaces:

- IP over ATM (IPoA)
- IP over PPP over ATM
- IP over PPPoE over ATM
- IP over Bridged Ethernet over ATM

Before you begin configuring dynamic interfaces, it is recommended that you review the following concepts:

- Dynamic interfaces
- Autodetection
- RADIUS authentication
- Profiles

Dynamic Interfaces

Although dynamic interfaces are created transparently, it is helpful to understand how *dynamic* interfaces differ from *static* interfaces.

A *dynamic interface* is created through some external event, typically through the receipt of data over a lower-layer link, such as an ATM virtual circuit (VC). Each layer of a *static interface* is created and configured through an existing configuration mechanism such as CLI or SNMP. In contrast, the layers of a dynamic interface are created based on the packets received on the link and can be configured through any one of the following:

- RADIUS authentication
- Profiles
- A combination of RADIUS authentication and profiles

Unlike static interfaces, dynamic interfaces are not restored through nonvolatile storage (NVS) after a reboot.

Autodetection

The system software performs a process called *autodetection*, also referred to as *autosensing*, to determine the layers of each dynamic interface. Autodetection is done when the system conditionally constructs interface layers based on the encapsulation type of the incoming packet.

Unlike static interfaces, which always allocate system resources upon creation, autodetection only uses system resources on demand based on what is detected in the incoming packet. Static interfaces always consume system resources, even when the interface is quiescent. Dynamic interfaces, however, are created as a result of traffic on the interface. Dynamic interfaces may also be dynamically deleted without your intervention, thereby allowing any consumed system resources to be returned.

RADIUS Authentication

RADIUS helps protect your network against unauthorized access. To accomplish this, RADIUS clients running on your system send authentication requests to a central RADIUS server. You can configure dynamic interfaces through RADIUS authentication.

When a packet is received, the authenticating interface, either PPP or ATM 1483, establishes a session with RADIUS and passes the username and password to the RADIUS server. For dynamic IPoA, the RADIUS username and password are obtained from the information specified by the **subscriber** command. The RADIUS server returns a grant or deny indication. If authentication is granted, the RADIUS attributes are returned, a user login is created, and the dynamic interfaces are configured from the RADIUS attributes.

ATM 1483 interfaces may receive configuration data from the RADIUS server in the form of *traffic-shaping* parameters.

Any changes made to a RADIUS configuration for a given dynamic interface do not take effect until an existing dynamic interface configured from this RADIUS entry is recreated, that is, deleted and then dynamically created.

Profiles

Dynamic interfaces can also be configured by profiles. A *profile* is a set of characteristics that act as a pattern. This pattern can then be dynamically assigned to interfaces. By using a profile, you reduce the management of a large number of interfaces by applying a set of characteristics to multiple interfaces.

When you are configuring a large number of interfaces with the same attributes at the higher layers, you can use a profile to factor out all the common attributes of each layer into one place. This action comprises one or more dynamic layers of the interface column. Once you define the static lower layers, a profile is assigned to the highest static layer of the interface column.

References

For information about RADIUS, consult the following resources:

- RFC 2865 – Remote Authentication Dial In User Service (RADIUS) (June 2000).
- RFC 2866 – RADIUS Accounting (June 2000).

About Configuring ATM for Dynamic Interfaces

To create dynamic interfaces over ATM, you create the static layers of the interface first, and then configure them to support a dynamic interface through autodetection. Figure 21-1 shows an example of the interface stacking of a dynamic IP over ATM 1483 interface and identifies the CLI commands you typically use.

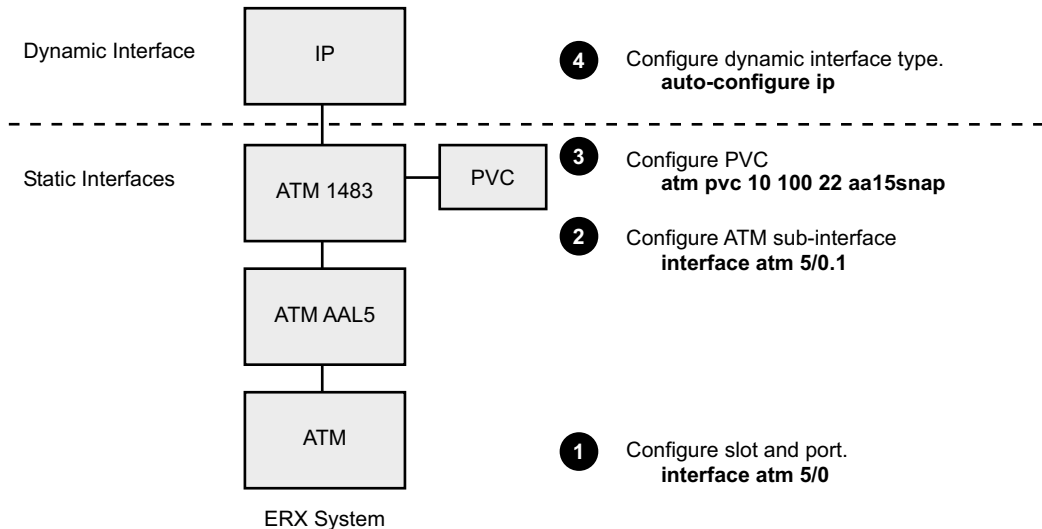

Figure 21-1 Configuring an ATM 1483 interface to support dynamic interfaces

On receipt of a packet, all dynamic layers above the ATM 1483 layer are created starting with the lowest dynamic layer. For example, in the case of a dynamic PPPoE interface, the PPPoE interface is created first, then the PPP interface, and then the IP interface.

If a failure occurs when any layer of the dynamic portion of the interface column is created, then the interface creation fails and the connection is denied. When a dynamic interface is destroyed, all dynamic layers above the ATM 1483 subinterface are destroyed, starting with the highest dynamic layer.

When you configure a dynamic interface, you must assign (or create and assign) a profile to the interface. Profile creation and assignment topics are discussed in depth in a different section of this document.

auto-configure Command

The **auto-configure** command is used to configure an ATM 1483 subinterface to support a dynamic interface. Once configured, the ATM 1483 subinterface performs autodetection to identify the encapsulation, resulting in the dynamic creation of the higher protocol layers. This command specifies the type(s) of next upper dynamic encapsulations that are accepted or detected by the static ATM 1483 interfaces. Dynamic encapsulations can be bridged Ethernet, IP, PPP, or PPPoE.

atm pvc Command

The **atm pvc** command is used to define the underlying circuit supporting an ATM 1483 subinterface. When you define a circuit with this command using the **aal5autoconfig** option, it causes the ATM 1483 encapsulation (LLC/SNAP encapsulation or VC multiplexed) to be autodetected. Alternatively, if you use the **aal5snap** or **aal5mux ip** option, the ATM 1483 encapsulation becomes fixed, but allows higher layers to be dynamic.

For example, to configure autodetection of the ATM 1483 encapsulation and all higher layers, you might enter:

```
host1(config-subif)#atm pvc 100 0 100 aal5autoconfig 0 0 0
```

About Configuring RADIUS for Dynamic Interfaces

Dynamic interfaces can be configured automatically through authentication and authorization by the RADIUS server. Initially, you create the static portion of the interface column by creating an ATM interface, ATM 1483 subinterface, and underlying ATM permanent virtual circuit (PVC).

subscriber Command

For dynamic interfaces that do not have a PPP layer, such as IPoA, the **subscriber** command allows you to configure an ATM 1483 subinterface to automatically be authenticated by the RADIUS server. The **subscriber** command uses a RADIUS username and optional password for identification and is available only for bridged Ethernet and IPoA configurations. This command is used for dynamic encapsulations that do not provide the authentication information remotely, as PPP does.

When PPP is a layer of the dynamic interface, once the PPP interface is dynamically created, the RADIUS username and password are obtained

from the remote client, and authentication is performed with the RADIUS server. The attributes obtained from RADIUS can then be used to configure any higher-layer dynamic interfaces, such as IP, that are built over PPP.

Configuring PPP and PPPoE Dynamic Interfaces

The ERX system supports dynamic PPP and PPPoE interfaces. The configuration procedure is very similar for each.

When using the **auto-configure** command, select only **ppp** or **pppoe**. The ERX system software automatically builds the necessary interfaces for you. When you indicate **pppoe**, upon the receipt of a PPPoE packet, the dynamic interface built is IP over PPP over PPPoE over ATM. Likewise, when you indicate **ppp**, the dynamic interface built is IP over PPP over ATM.

Figure 21-2 shows a dynamic PPP interface column.

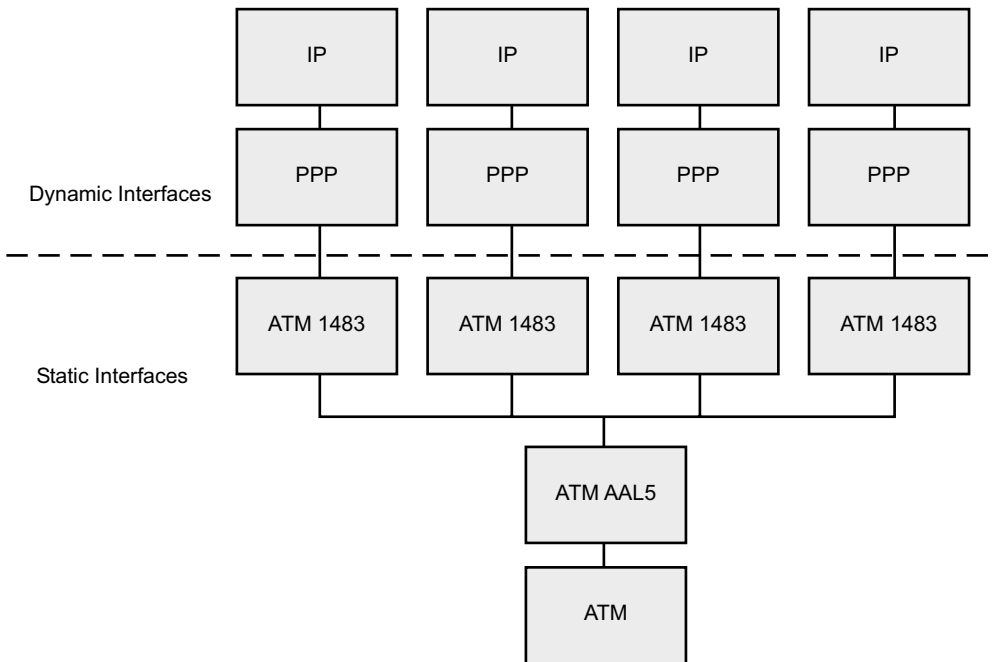

Figure 21-2 Dynamic PPP interface columns

Figure 21-3 shows a dynamic PPPoE interface column and illustrates how PPPoE permits multiple IP sessions over each ATM 1483 circuit.

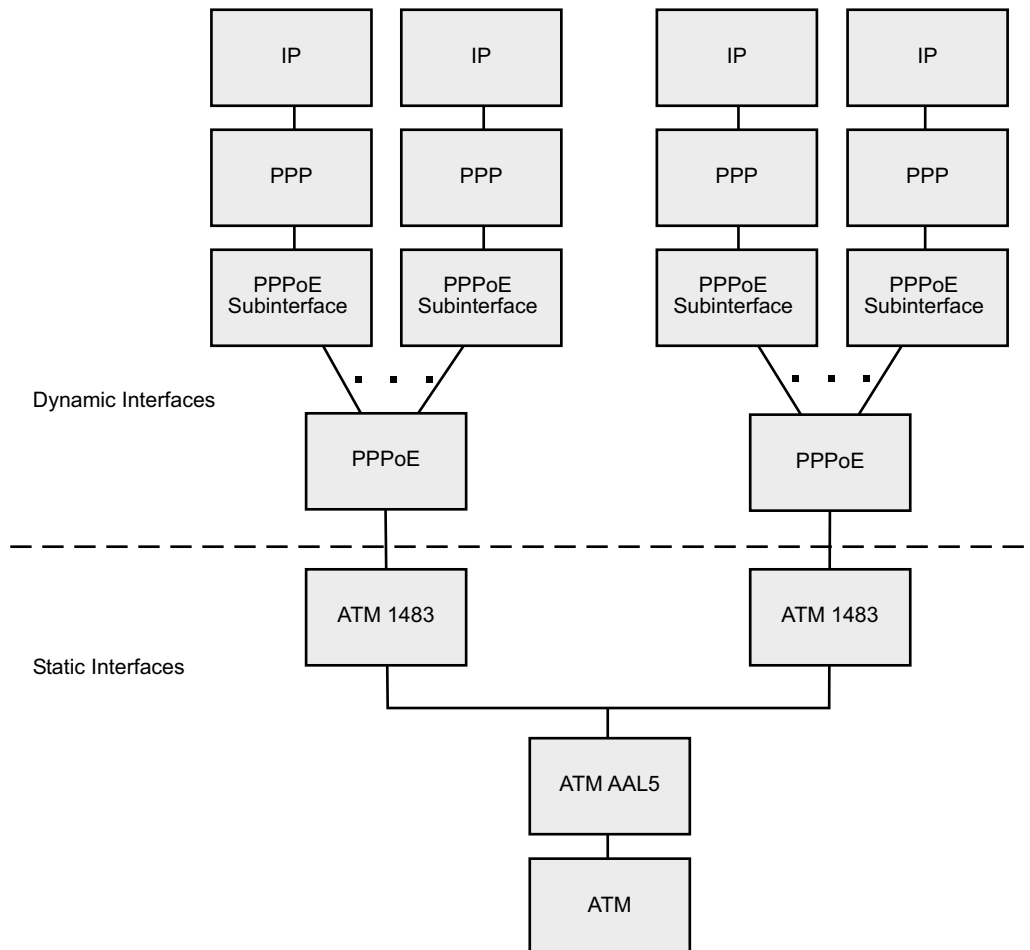

Figure 21-3 Dynamic PPPoE interface columns

You can specify either or both **ppp** and **pppoe** for the interface by specifying the **auto-configure** command for each type of interface. The first packet received defines the type of dynamic interface that is created.

Configuring a PPP or PPPoE Dynamic Interface

To configure an ATM 1483 subinterface to support a dynamic PPP or PPPoE interface:

- 1 Configure a physical interface.

```
host1(config)#interface atm 5/0
```

- 2 Configure an ATM 1483 subinterface.

```
host1(config-if)#interface atm 5/0.1
```

- 3 Configure a PVC by specifying the virtual circuit descriptor (VCD), the virtual path identifier (VPI), the virtual channel identifier (VCI), and the encapsulation type.



Note: If the encapsulation type is to be autodetected, use the **aal5autoconfig** option.

```
host1(config-subif)#atm pvc 10 100 22 aal5snap
```

or

```
host1(config-subif)#atm pvc 10 100 22 aal5autoconfig
```

- 4 Assign a profile.

```
host1(config-subif)#profile ppp foo
```

or

```
host1(config-subif)#profile pppoe foobar
```

- 5 Configure the subinterface to recognize dynamic PPP and/or PPPoE.

```
host1(config-subif)auto-configure ppp
```

and/or

```
host1(config-subif)auto-configure pppoe
```



Note: In addition, you could also specify **ip** or **bridgedEthernet**.

- 6 (Optional) Verify your configuration.

```
host1#show atm subinterface atm 5/0.1
```

atm pvc

- Use to configure a PVC on an ATM interface. Specify one of the following encapsulation types:
 - › **aal5autoconfig** – enables autodetection of the 1483 encapsulation (LLC/SNAP or VC multiplexed).
 - › **aal5snap** – specifies a logical link control (LLC) encapsulated circuit; LLC/Subnetwork Access Protocol (LLC/SNAP) precedes the protocol datagram.
 - › **aal5mux ip** – specifies a VC multiplexed circuit. This option is used for IP only.

- Example

```
host1(config-subif)#atm pvc 6 0 11 aal5autoconfig
```
- Use the **no** version to remove the specified PVC.

auto-configure

- Use to configure an ATM subinterface to support a dynamic interface. Specifies the type(s) of dynamic encapsulation that will be accepted/detected by the ATM 1483 subinterface.
- This command makes the layers above ATM 1483 *dynamic*.
- Select the dynamic next upper interface type from these options:
bridgedEthernet, ip, ppp, or pppoe
- You may enter the command repetitively to support multiple dynamic interface types.
- Example

```
host1(config-subif)auto-configure pppoe
```
- Use the **no** version to disable detection of the specified encapsulation.

interface atm

- Use to configure an ATM interface or subinterface type in the *slot/port.subinterface* format:
 - › A *slot* refers to a system chassis slot.
 - › A *port* refers to a T3, E3, OC3, or OC12 module I/O port.
 - › A *subinterface* is a mechanism that allows a single physical interface to support multiple logical interfaces or networks. Several logical interfaces or networks can be associated with a single hardware interface. Protocols such as ATM require that you create one or more virtual circuits over which your data traffic is transmitted to higher layers in the protocol stack. A *subinterface* is identified by a user-defined number in the range 1–4294967293.
- Example

```
host1(config-if)#interface atm 5/0.1
```
- Use the **no** version to remove the subinterface or the logical interface.

profile

- Use to assign a profile.
- You must specify the encapsulation type to which the profile applies:
bridgedEthernet, ip, ppp, pppoe, or any.
- Specify a profile name with up to 80 characters.
- Example

```
host1(config-subif)#profile ppp foo
```
- Use the **no** version to remove a profile assignment.

Configuring PPPoE Dynamic Interfaces over Static PPPoE Interfaces

The ERX system supports dynamic PPPoE subinterfaces over static PPPoE major interfaces. The PPPoE major interfaces can be created over ATM, Ethernet, or VLANs.

Dynamic PPPoE over Static PPPoE with ATM Interface Columns

Figure 21-4 shows a dynamic PPPoE subinterface column and illustrates an alternative method for PPPoE to permit multiple IP sessions over each ATM 1483 circuit.

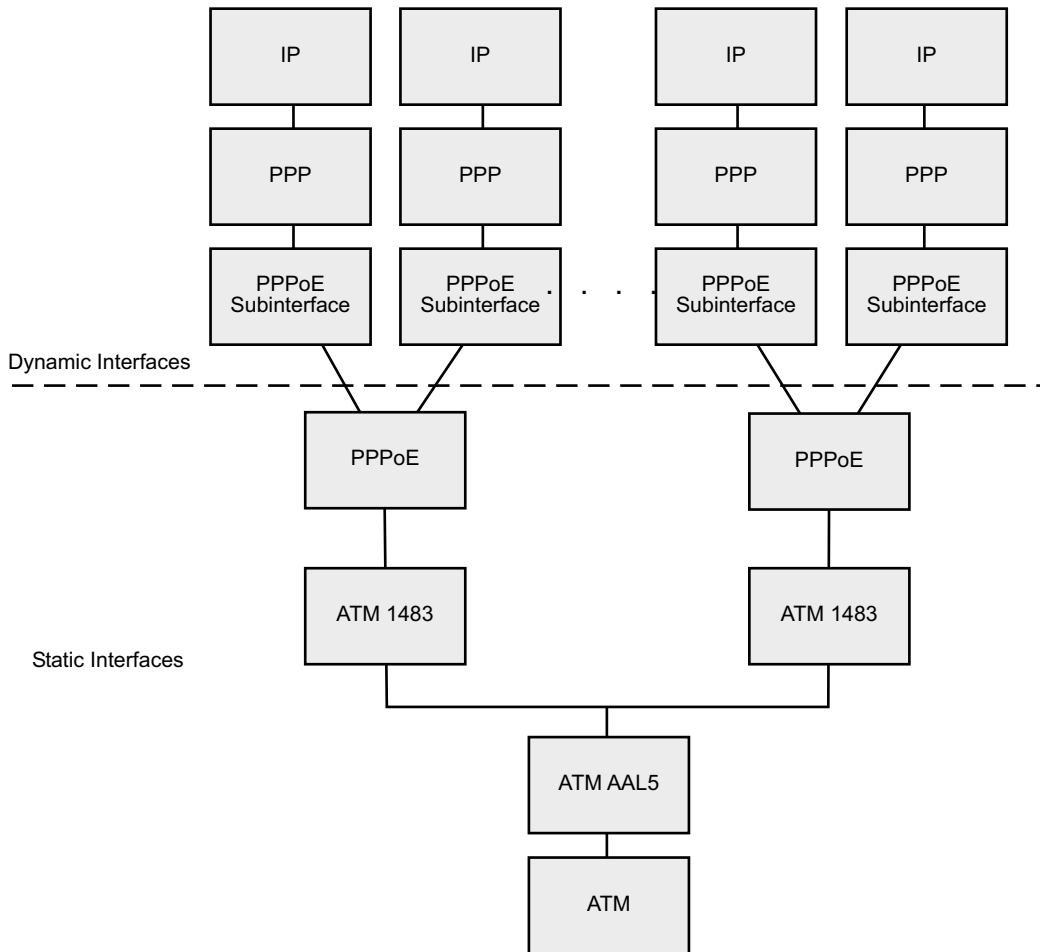

Figure 21-4 Dynamic PPPoE over static PPPoE with ATM interface columns

Configuring a PPPoE Dynamic Subinterface with ATM Interface Columns
To configure an ATM 1483 subinterface to support a dynamic PPPoE subinterface:

- 1 Configure a physical interface.

```
host1(config)#interface atm 5/0
```
- 2 Configure an ATM 1483 subinterface.

```
host1(config-if)#interface atm 5/0.1
```
- 3 Configure a PVC by specifying the virtual circuit descriptor (VCD), the virtual path identifier (VPI), the virtual channel identifier (VCI), and the encapsulation type.



Note: If the encapsulation type is to be autodetected, use the **aal5autoconfig** option.

```
host1(config-subif)#atm pvc 10 100 22 aal5snap
```

or

```
host1(config-subif)#atm pvc 10 100 22 aal5autoconfig
```

- 4 Configure a PPPoE major interface.

```
host1(config-if)#interface atm 5/0.1.1
```
- 5 Set the encapsulation type to PPPoE.

```
host1(config-subif)#encapsulation pppoe
```
- 6 Assign a profile.

```
host1(config-subif)#profile pppoe-profile
```
- 7 Configure the interface to recognize dynamic PPPoE subinterfaces.

```
host1(config-subif)pppoe auto-configure
```
- 8 (Optional) Verify your configuration.

```
host1#show atm subinterface atm 5/0.1
```

Dynamic PPPoE over Static PPPoE with Ethernet and VLAN Interface Columns

Figure 21-4 shows a dynamic PPPoE subinterface column and illustrates an alternative method for PPPoE to permit multiple IP sessions over each VLAN. Note that you can also configure PPPoE over an Ethernet interface without VLANs.

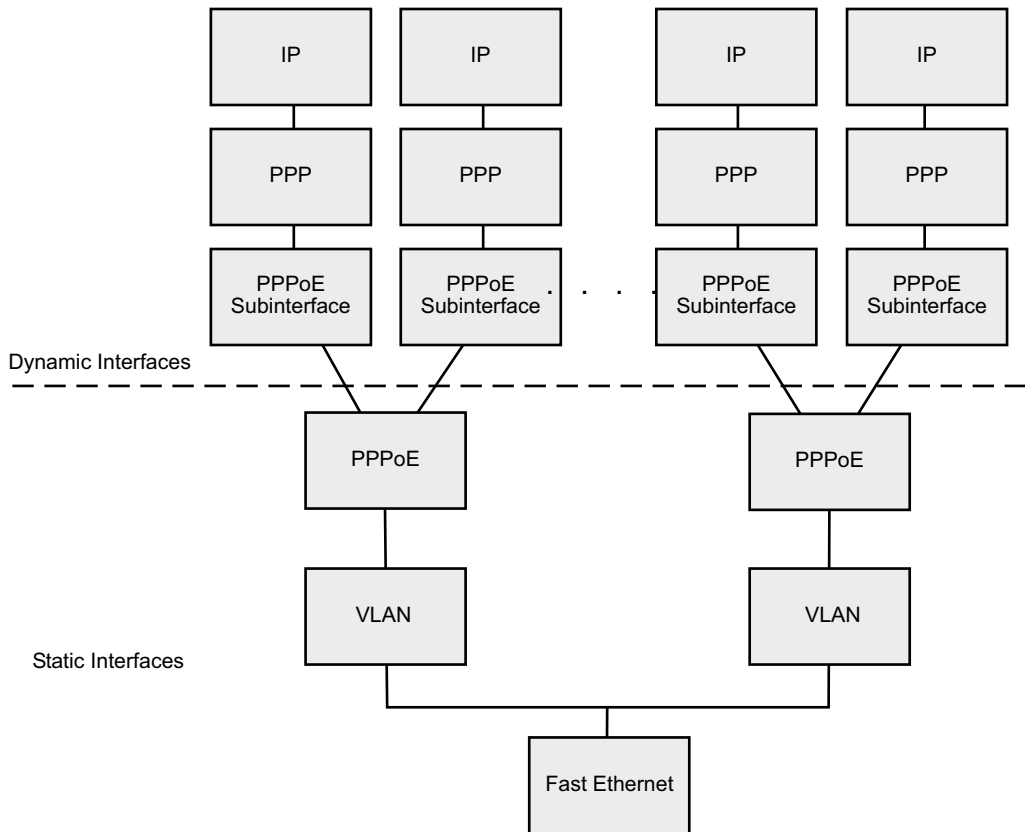

Figure 21-5 Dynamic PPPoE over static PPPoE with VLAN interface columns

Configuring a PPPoE Dynamic Subinterface with VLAN Ethernet Interface Columns

To configure a VLAN subinterface to support a dynamic PPPoE subinterface:

- 1 Specify an FE or a GE port.

```
host1(config)#interface fastethernet 4/1
```

- 2 Specify VLAN as the encapsulation method.

```
host1(config-if)#encapsulation vlan
```

The VLAN major interface is added.

- 3 Create a VLAN subinterface by adding a subinterface number to the interface identification command.

```
host1(config-if)#interface fastethernet 4/1.1
```

- 4 Assign a VLAN ID for the subinterface.
`host1(config-if)#vlan id 400`
- 5 Set the encapsulation type to PPPoE.
`host1(config-subif)#encapsulation pppoe`
- 6 Assign a profile.
`host1(config-subif)#profile pppoe-profile`
- 7 Configure the interface to recognize dynamic PPPoE subinterfaces.
`host1(config-subif)pppoe auto-configure`
- 8 (Optional) Verify your configuration.
`host1#show vlan subinterface fastethernet 4/1.1`

atm pvc

- Use to configure a PVC on an ATM interface. Specify one of the following encapsulation types:
 - › **aal5autoconfig** – enables autodetection of the 1483 encapsulation (LLC/SNAP or VC multiplexed).
 - › **aal5snap** – specifies a logical link control (LLC) encapsulated circuit; LLC/Subnetwork Access Protocol (LLC/SNAP) precedes the protocol datagram.
 - › **aal5mux ip** – specifies a VC multiplexed circuit. This option is used for IP only.
- Example
`host1(config-subif)#atm pvc 6 0 11 aal5autoconfig`
- Use the **no** version to remove the specified PVC.

encapsulation pppoe

- Use to configure PPPoE as the encapsulation method for the interface.
- Example
`host1(config-if)#encapsulation pppoe`
- Use the **no** version to disable PPPoE on the interface.

encapsulation vlan

- Use to configure VLAN as the encapsulation method for the interface.
- Example
`host1(config-if)#encapsulation vlan`
- Use the **no** version to disable VLAN on an interface.

interface atm

- Use to configure an ATM interface or subinterface type in the *slot/port.subinterface* format:
 - › A *slot* refers to a system chassis slot.
 - › A *port* refers to a T3, E3, OC3, or OC12 module I/O port.
 - › A *subinterface* is a mechanism that allows a single physical interface to support multiple logical interfaces or networks. Several logical interfaces or networks can be associated with a single hardware interface. Protocols such as ATM require that you create one or more virtual circuits over which your data traffic is transmitted to higher layers in the protocol stack. A *subinterface* is identified by a user-defined number in the range 1–4294967293.
- Example

```
host1(config-if)#interface atm 5/0.1
```
- Use the **no** version to remove the subinterface or the logical interface.

pppoe auto-configure

- Use to set up the system to dynamically create PPPoE subinterfaces on the PPPoE major interfaces.
- Example

```
host1(config-subif)#pppoe auto-configure
```
- Use the **no** version to remove this configuration.

profile

- Use to assign a profile.
- Specify a profile name with up to 80 characters.
- Example

```
host1(config-subif)#profile ppp foo
```
- Use the **no** version to remove a profile assignment.

vlan id

- Use to specify the VLAN ID.
- Use a VLAN ID that is in the range of 0–4095 and is unique within the Ethernet interface.
- Example

```
host1(config-if)#vlan id 400
```
- Issue the **vlan id** command before any upper bindings are made, such as IP or PPPoE.
- Use the optional keyword **untagged** to specify that frames be sent untagged. The keyword is valid only for VLAN ID 0. It allows tagged frames to be received, but sends out untagged frames.
- There is no **no** version.

Configuring IPoA Dynamic Interfaces

Dynamic IP over ATM (IPoA) interfaces are supported by system software. An IPoA interface is IP over ATM 1483 over ATM AAL5 over ATM. See Figure 21-1.

An IPoA interface configuration is typically used as a high-speed access service or uplink to another router. A common use is to provision IP over ATM circuits over DSL to connect businesses to the Internet—a B-RAS alternative to circuit aggregation. All provisioning can be through the RADIUS server to minimize any configuration of the system.

When IP packets are received over ATM circuits, the IP interfaces are dynamically constructed over the corresponding ATM 1483 interfaces from the configuration data received from the RADIUS server, a profile, or both.

Figure 21-6 shows the protocol layers that represent the IPoA interface columns, and the layers within the interface columns that are static and dynamic.

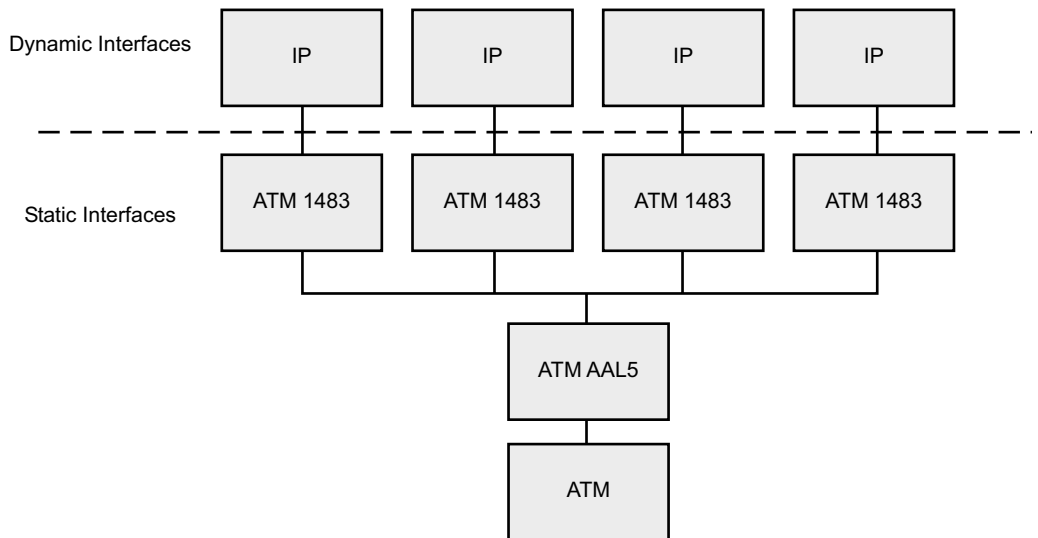

Figure 21-6 IPoA interface columns

When you configure dynamic IPoA interfaces, you must either assign a subscriber identification, assign a profile, or do both.

Configuring an IPoA Dynamic Interface

To configure dynamic IPoA interfaces:

- 1 Configure a physical interface.

```
host1(config)#interface atm 5/0
```

- 2 Configure an ATM subinterface.

```
host1(config-if)#interface atm 5/0.1
```

- 3 Configure a PVC by specifying the VCD, the VPI, the VCI, and the encapsulation type.



Note: If the encapsulation type is to be autodetected, use the **aal5autoconfig** option.

```
host1(config-subif)#atm pvc 10 100 22 aal5snap
```

or

```
host1(config-subif)#atm pvc 10 100 22 aal5autoconfig
```

- 4 Assign a profile.

```
host1(config-subif)#profile ip foo
```

- 5 (Optional) Assign subscriber identification.

```
host1(config-subif)#subscriber ip user charlie domain  
myispname password lucy
```

- 6 Configure the subinterface to recognize a dynamic IP interface type.

```
host1(config-subif)auto-configure ip
```

- 7 (Optional) Verify your configuration.

```
host1#show atm subinterface atm 5/0.1
```

atm pvc

- Use to configure a PVC on an ATM interface. Specify one of the following encapsulation types:
 - › **aal5autoconfig** – enables autodetection of the 1483 encapsulation (LLC/SNAP or VC multiplexed).
 - › **aal5snap** – specifies an LLC encapsulated circuit; LLC/SNAP precedes the protocol datagram.
 - › **aal5mux ip** – specifies a VC multiplexed circuit. This option is used for IP only.

- Example

```
host1(config-subif)# atm pvc 6 0 11 aal5autoconfig
```

- Use the **no** version to remove the specified PVC.

auto-configure

- Use to configure an ATM subinterface to support a dynamic interface. Specifies the type(s) of dynamic encapsulation that will be accepted/detected by the ATM 1483 subinterface.
- This command makes the layers above ATM 1483 *dynamic*.
- Select the dynamic next upper interface type from these options: **bridgedEthernet**, **ip**, **ppp**, or **pppoe**
- You may enter the command repetitively to support multiple dynamic interface types.
- Example

```
host1(config-subif)auto-configure pppoe
```
- Use the **no** version to disable detection of the specified encapsulation.

interface atm

- Use to configure an ATM interface or subinterface type in the *slot/port.subinterface* format:
 - › A *slot* refers to a system chassis slot.
 - › A *port* refers to a T3, E3, OC3, or OC12 module I/O port.
 - › A *subinterface* is a mechanism that allows a single physical interface to support multiple logical interfaces or networks. Several logical interfaces or networks can be associated with a single hardware interface. Protocols such as ATM require that you create one or more virtual circuits over which your data traffic is transmitted to higher layers in the protocol stack. A *subinterface* is identified by a user-defined number in the range 1–4294967293.
- Use the **no** version to remove the subinterface or the logical interface.

profile

- Use to assign a profile.
- You must specify the encapsulation type to which the profile applies: **bridgedEthernet**, **ip**, **ppp**, **pppoe**, or **any**.
- Specify a profile name with up to 80 characters.
- Example

```
host1(config-subif)#profile ppp foo
```
- Use the **no** version to remove a profile assignment.

subscriber

- Use to configure a local subscriber on the ERX system to support authentication and configuration from RADIUS for a dynamic IPoA or bridged Ethernet interface.
- When you configure a subscriber, you must specify the following:
 - › *interfaceType* – type of dynamic interface, **bridgedEthernet** or **ip**
 - › *userNameUsage* – how the dynamic interface uses the username for authentication purposes

- **user** – use the name as specified
- **user-prefix** – use the name as a prefix to the interface physical location. The system automatically postpends the physical location of the user to the username string. The username format is *user.slot.port.vpi.vci*. The resulting username string is then used to be authenticated by the RADIUS server.
 - › *userName* – RADIUS username
 - › *domainName* – domain name
- You may optionally supply password information:
 - › *passwordUsage* – how the dynamic interface uses the password for authentication purposes
 - **password** – use the password as specified
 - **password-prefix** – use the password as a prefix to the interface physical location. The system automatically postpends the physical location of the user to the password string. The password format is *password.slot.port.vpi.vci*. The resulting password string is then used to authenticate with the RADIUS server.
 - › *password* – the RADIUS password
- Example

```
host1(config-subif)#subscriber ip user-prefix charlie domain
myisp password-prefix lucy
```
- Use the **no** version to remove the subscriber.

Configuring Bridged Ethernet Dynamic Interfaces

A bridged Ethernet interface is IP over bridged Ethernet over ATM 1483 over ATM AAL5 over ATM.

When bridged Ethernet packets are received over ATM circuits, the bridged Ethernet and IP interfaces are dynamically constructed over the corresponding ATM 1483 interfaces and use the configuration data received from the RADIUS server, a profile, or both.

Figure 21-7 shows the protocol layers that represent the bridged Ethernet interface columns, and the layers within the interface columns that are static and dynamic.

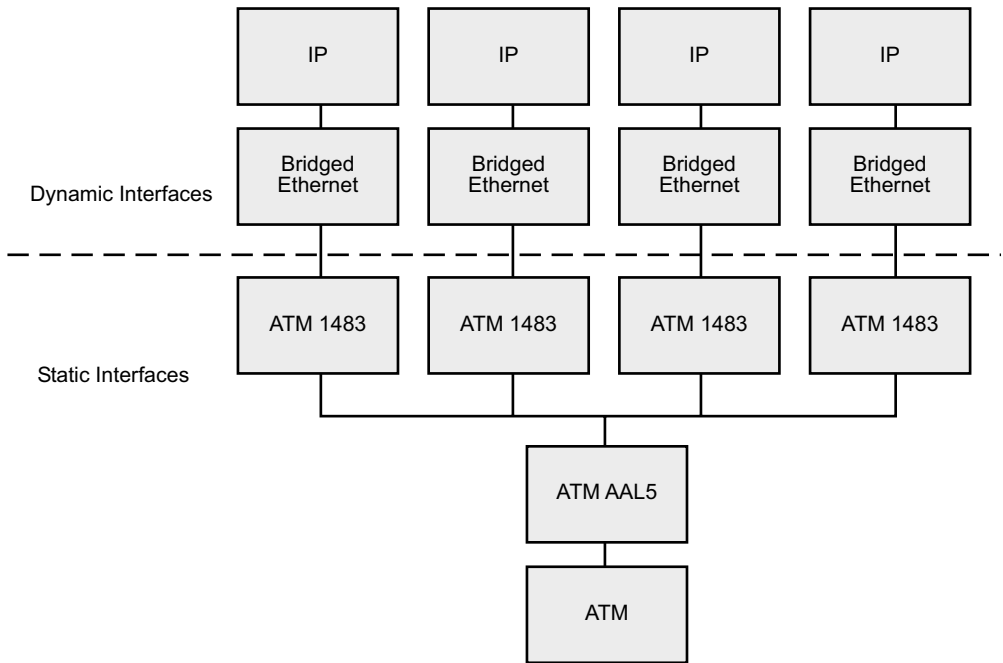

Figure 21-7 Bridged Ethernet interface columns

Configuring a Bridged Ethernet Dynamic Interface

When you configure dynamic bridged Ethernet interfaces, you must assign a profile. You may optionally assign a subscriber identification.

To configure dynamic bridged Ethernet interfaces:

- 1 Configure a physical interface.

```
host1(config)#interface atm 2/0
```
- 2 Configure an ATM subinterface.

```
host1(config-if)#interface atm 2/0.1
```
- 3 Configure a PVC by specifying the VCD, the VPI, the VCI, and the encapsulation type.



Note: If the encapsulation type is to be autodetected, use the **aal5autoconfig** option.

```
host1(config-subif)#atm pvc 10 100 22 aal5snap
```

OR

```
host1(config-subif)#atm pvc 10 100 22 aal5autoconfig
```

- 4 Configure the subinterface to recognize a dynamic bridged Ethernet interface type.

```
host1(config-subif)#auto-configure bridgedEthernet
```

- 5 Assign a profile to match the encapsulation type of bridged Ethernet.

```
host1(config-subif)#profile bridgedEthernet foo
```

- 6 (Optional) Assign subscriber identification.

```
host1(config-subif)#subscriber bridgedEthernet user charlie
domain myisp password lucy
```

- 7 (Optional) Verify your configuration.

```
host1#show atm subinterface atm 2/0.1
```

atm pvc

- Use to configure a PVC on an ATM interface. Select one of the following encapsulation types:
 - › **aal5autoconfig** – enables autodetection of the 1483 encapsulation (LLC/SNAP or VC multiplexed).
 - › **aal5snap** – specifies a LLC encapsulated circuit; LLC/SNAP precedes the protocol datagram.
 - › **aal5mux ip** – specifies a VC multiplexed circuit. This option is used for IP only.
- Example

```
host1(config-subif)#atm pvc 6 0 11 aal5autoconfig
```
- Use the **no** version to remove the specified PVC.

auto-configure

- Use to configure an ATM subinterface to support a dynamic interface. Specifies the type(s) of dynamic encapsulation that will be accepted/detected by the ATM 1483 subinterface.
- This command makes the layers above ATM 1483 *dynamic*.
- Select the dynamic next upper interface type from these options: **bridgedEthernet**, **ip**, **ppp**, or **pppoe**
- You may enter the command repetitively to support multiple dynamic interface types.
- Example

```
host1(config-subif)auto-configure pppoe
```
- Use the **no** version to disable detection of the specified encapsulation.

interface atm

- Use to configure an ATM interface or subinterface type in the *slot/port.subinterface* format:

- › A *slot* refers to a system chassis slot.
 - › A *port* refers to a T3, E3, OC3, or OC12 module I/O port.
 - › A *subinterface* is a mechanism that allows a single physical interface to support multiple logical interfaces or networks. Several logical interfaces or networks can be associated with a single hardware interface. Protocols such as ATM require that you create one or more virtual circuits over which your data traffic is transmitted to higher layers in the protocol stack. A *subinterface* is identified by a user-defined number in the range 1–4294967293.
- Use the **no** version to remove the subinterface or the logical interface.

profile

- Use to assign a profile.
- You must specify the encapsulation type to which the profile applies: **bridgedEthernet**, **ip**, **ppp**, **pppoe**, or **any**.
- Specify a profile name with up to 80 characters.
- Example

```
host1(config-subif)#profile bridgedEthernet foo
```
- Use the **no** version to remove a profile assignment.

subscriber

- Use to configure a local subscriber on the ERX system to support authentication and configuration from RADIUS for a dynamic bridged Ethernet or IPoA interface.
- When you configure a subscriber, you must specify the following:
 - › *interfaceType* – type of dynamic interface, **bridgedEthernet** or **ip**.
 - › *userNameUsage* – how the dynamic interface uses the username for authentication purposes
 - **user** – use the name as specified
 - **user-prefix** – use the name as a prefix to the interface physical location. The system automatically postpends the physical location of the user to the username string. The username format is *user.slot.port.vpi.vci*. The resulting username string is then used to authenticate with the RADIUS server.
 - › *userName* – RADIUS username
 - › *domainName* – domain name
- You may optionally supply password information:
 - › *passwordUsage* – how the dynamic interface uses the password for authentication purposes
 - **password** – use the password as specified
 - **password-prefix** – use the password as a prefix to the interface physical location. The system automatically postpends the physical location of the user to the password string. The password format is *password.slot.port.vpi.vci*. The resulting password string is then used to authenticate with the RADIUS server.

- › *password* – the RADIUS password
- Example

```
host1(config-subif)#subscriber ip user-prefix charlie domain
myisp password-prefix lucy
```
- Use the **no** version to remove the subscriber.

Configuring a Dynamic Interface from a Profile

You define profiles using CLI commands similar to the ones you would use to configure static interfaces. When configuring profiles, you have the option of choosing to specify every layer explicitly or to specify a subset of layers.

When a dynamic interface is configured, the configuration data received from the RADIUS authentication server typically overrides configuration data obtained from a profile.

In contrast to static PPP interfaces (above which only dynamic IP interfaces may be created), static ATM 1483 subinterfaces support recognition and creation of four upper dynamic interface types or *encapsulations*: bridged Ethernet, IP, PPP, and PPPoE. The encapsulation type is identified via the **auto-configure** command. For flexibility, the system offers the ability to configure an ATM 1483 subinterface with distinct profile assignments for each encapsulation type supported by the **auto-configure** command.

Each profile typically contains configuration attributes for the expected encapsulation, in addition to attributes for other higher-interface layers through IP. If your configuration of upper layers is intended to be different depending on which incoming encapsulation is received by the ATM 1483 subinterface, then you should configure and assign separate profiles for each encapsulation type. If your configuration of upper layers is the same for more than one encapsulation type, you can configure one profile and assign it for those encapsulation types.

Profile Characteristics

Currently, profiles support bridged Ethernet, IP, Multilink PPP, PPP, and PPPoE interfaces. You create a profile with a specific set of characteristics. You then assign the profile to multiple interfaces instead of creating separate interfaces with identical attributes. Once you create a profile, you can assign it to static ATM 1483 or static PPP interfaces on different devices.

Profiles contain attributes for IP, Multilink PPP, PPP, or PPPoE. Profiles do not contain attributes for bridged Ethernet.

IP Characteristics

A profile can contain one or more of the following IP characteristics:

- `access-route` – enables the creation of host access routes on an interface
- `address` – configures an IP address on an interface
- `directed-broadcast` – enables directed broadcast forwarding
- `mtu` – configures the maximum transmission unit for a network
- `redirects` – enables transmission of ICMP redirect messages
- `source address validation` – verifies that a packet has been sent from a valid source address
- `unnumbered` – configures IP on this interface without a specific address
- `virtual-router` – specifies a virtual router (VR) to which interfaces created by this profile will be attached

MLPPP and PPP Characteristics

A profile can contain one or more of the following MLPPP or PPP characteristics:

- `aaa-profile` – assigns an AAA profile
- `authentication` – requests PAP or CHAP authentication from a PPP peer
- `authentication virtual router` – virtual router for the authentication virtual router context
- `chap challenge length` – modifies the length of the CHAP challenge
- `ipcp-netmask` – controls the negotiation of the IPCP netmask option 0x90; *disabled* indicates do not negotiate; *enabled* indicates negotiate
- `keepalive` – specifies a keepalive value in seconds
- `log` – enables packet or state machine logging for any dynamic interfaces that use the profile
- `magic-number disable` – disables negotiation of the local magic number
- `mru` – configures the maximum receive unit size for the interface
- `multilink enable` – for MLPPP interfaces only, enables the creation of dynamic MLPPP interfaces

- `passive-mode` – forces the interface into passive mode before LCP negotiation begins, for a period of one second to enable slow clients to start up and initiate the LCP negotiation
- `peer dns` – resolves conflicts when the ERX system and the PPP peer system have the primary and secondary DNS addresses configured with different values
- `peer wins` – resolves conflicts when the ERX system and the PPP peer system have the primary and secondary WINS addresses configured with different values

PPPoE Characteristics

A profile can contain one or more of the following PPPoE characteristics:

- `AC name` – access concentrator name
- `always-offer` – causes the system to offer to set up a session for the client, even if the system has insufficient resources to establish a session
- `duplicate-protection` – prevents a client from establishing more than one session using the same MAC address
- `message string` – PADM message of the minute
- `sessions` – number of subinterfaces permitted on a PPPoE major interface
- `url` – URL string sent to the new client
- `control packet tracing` – packet traces for PPPoE dynamic interfaces

Working with Profiles

Figure 21-8 shows how to create a profile and assign characteristics to it.

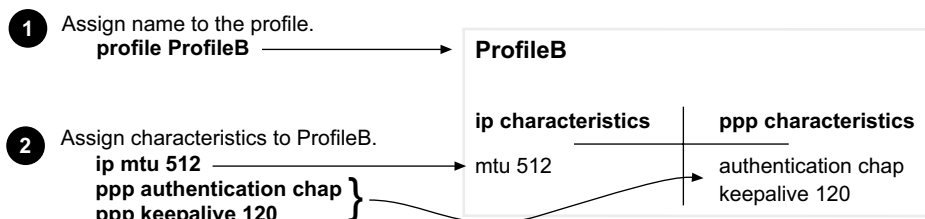

Figure 21-8 Creating and configuring a profile

Figure 21-9 shows how to assign a profile to static interfaces. These static interfaces will create dynamic interfaces above them.

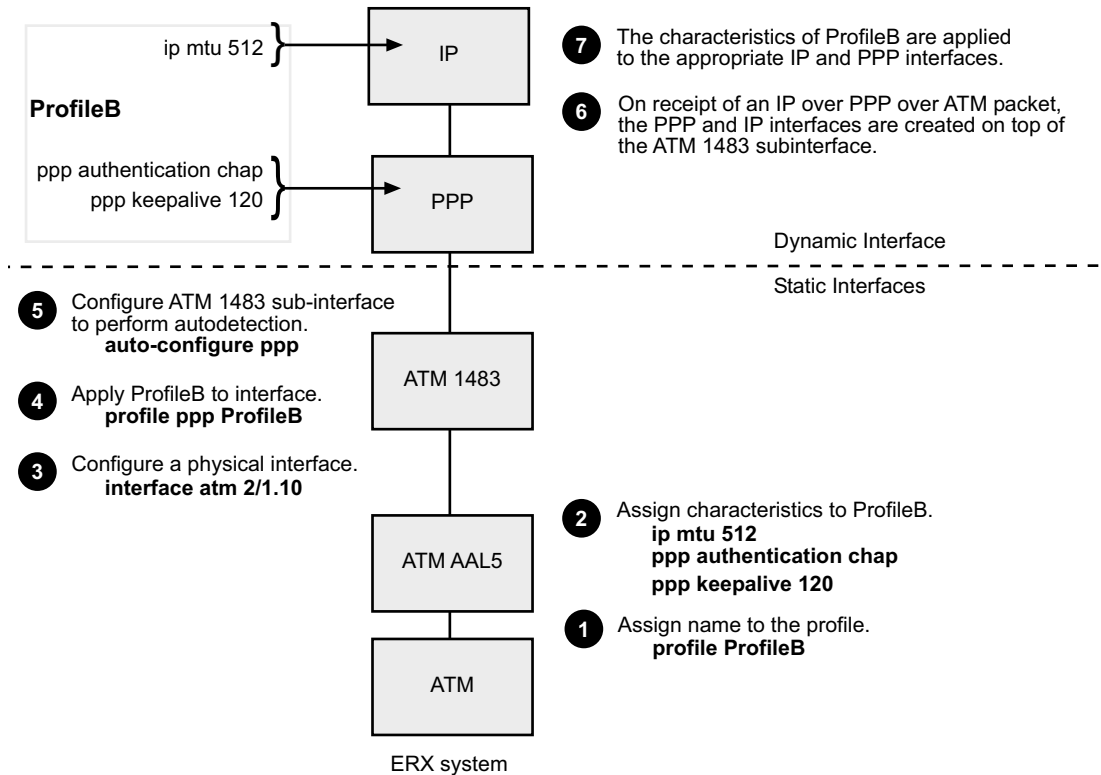

Figure 21-9 Assigning a profile to a static interface

Configuring a Profile

You can create a profile using CLI commands similar to those used to create the equivalent static interfaces. You can configure a profile for bridged Ethernet, IP, MLPPP, PPP, or PPPoE interfaces.

For example:

- 1 Create a profile by assigning it a name.

```
host1(config)#profile foo
```
- 2 Specify a VR to which dynamic IP interfaces created using this profile will be assigned.

```
host1(config-profile)#ip virtual-router egypt
```
- 3 Specify an IP loopback interface with which dynamic IP interfaces created using this profile will be associated.

```
host1(config-profile)#ip unnumbered loopback 0
```

4 Configure IPCP option 0x90.

```
host1(config-profile)#ppp ipcp netmask
```

5 Optionally set IP, MLPPP, PPP, or PPPoE characteristics.

ip access-routes

- Use to enable an access route in a profile.
- Example

```
host1(config-profile)#ip access-routes
```

- Use the **no** version to remove the access route.

ip address

- Use to assign an IP address to a profile.
- Example

```
host1(config-profile)#ip address 192.13.5.61
```

- Use the **no** version to remove the IP address assignment from the profile.

ip directed-broadcast

- Use to enable a directed broadcast address in a profile.
- Example

```
host1(config-profile)#ip directed-broadcast
```

- Use the **no** version to remove the directed broadcast address from the profile.

ip mtu

- Use to assign the maximum transmission unit size sent on an IP interface.
- Example

```
host1(config-profile)#ip mtu 1000
```

- Use the **no** version to remove the assignment from the profile.

ip redirects

- Use to enable the sending of redirect messages if the software is forced to resend a packet through the same interface on which it was received.
- Example

```
host1(config-profile)#ip redirects
```

- Use the **no** version to remove the assignment from the profile.

ip sa-validate

- Use to enable source address validation.
- Example

```
host1(config-profile)#ip sa-validate
```
- Use the **no** version to disable source address validation.

ip unnumbered

- Use to specify the unnumbered interface with which dynamic interfaces created with the profile are associated.
- You can configure a loopback using RADIUS instead of adding one to the profile using the **ip unnumbered loopback** command.
- Example

```
host1(config-profile)#ip unnumbered loopback 5
```
- Use the **no** version to remove the assignment from the profile.

ip virtual-router

- Use to assign a VR to a profile. Interfaces created by the profile are attached to this VR.
- If you do not specify a VR with the **ip virtual-router** command, you must use RADIUS to specify a VR to which the dynamic interfaces are assigned. During the process of creating a dynamic interface, the ERX system first checks RADIUS for a VR. If both RADIUS and the profile are configured to assign the VR, RADIUS overrides the profile.
- Before specifying the VR with the **ip virtual-router** command or RADIUS, first create it from Global Configuration mode with the **virtual-router** command.
- Example

```
host1(config-profile)#ip virtual-router salem1
```
- Use the **no** version to remove the VR assignment from the profile. If no VR is specified via RADIUS, then any subsequent use of the profile to create a dynamic interface fails for lack of a VR.

ppp aaa-profile

- Use to assign an AAA profile to static and dynamic, multilink and nonmultilink PPP interfaces.
- The PPP application associates the AAA profile with the interface and passes the AAA profile to AAA for authentication.
- If an AAA profile is deleted after it has been assigned to an interface, AAA will deny the authentication and log a message.
- When you remove an AAA profile, it does not remove any corresponding bindings between PPP interfaces or interface profiles and the AAA profile. If an AAA profile with the same name is added, the interface cannot authenticate until the AAA profile is reassigned.



Note: Although an AAA profile and an interface profile have similar functionality, they are not related and should be treated differently.

- Example

```
host1(config-if)#ppp aaa-profile westford24
```

- Use the **no** version to remove the AAA profile assignment.



Note: For more information on AAA profiles, see the *ERX Broadband Access Configuration Guide, Chapter 1, Configuring Remote Access to the ERX System*.

ppp authentication

- Use to require authentication from the PPP peer.
- Specify either PAP or CHAP as the primary authentication protocol. Optionally, specify the other (that is, CHAP or PAP) authentication protocol as the alternative. For example, suppose you specify **pap** as the primary authentication protocol and **chap** as the alternate:

```
host1(config-profile)#ppp authentication pap chap
```

- The system requests the use of PAP as the authentication protocol (because it appears first in the command line). If the peer system refuses to use PAP, the system requests the CHAP protocol. If the peer system refuses to negotiate authentication, the system terminates the PPP session.
- Specify a virtual router for the authentication virtual router context.
- `host1(config-if)#ppp authentication virtual-router boston pap chap` This command is available in static configurations and in profiles.
- The system supports the MD5 authentication algorithm for CHAP authentication.
- Use the **no** version to specify that the system does not require authentication.

ppp chap-challenge-length



- Use to modify the length of the CHAP challenge by specifying the allowable minimum length and maximum length.
- **Caution:** We recommend that you do NOT use the `ppp chap-challenge-length` command; increasing the minimum length (from the default 16 bytes) or decreasing the maximum length (from the default 32 bytes) reduces the security of your system.

- Specify the minimum and maximum lengths in bytes in the range 8–63.
- The maximum length must be greater than or equal to the minimum length.
- Example

```
host1(config-if)#ppp chap-challenge-length 24 28
```

- Use the **no** version to restore the default minimum 16 bytes and default maximum 32 bytes.

ppp ipcp netmask

- Use to specify Internet Protocol Control Protocol (IPCP) option 0x90 for each PPP interface. By default, IPCP option 0x90 is disabled on the interface.
- IPCP option 0x90 is a nonstandard option that allows a peer to request the netmask associated with the assigned IP address.

- The netmask can be specified via RADIUS attribute 9, Framed-Ip-Netmask. If the netmask is 255.255.255.255, the option is not negotiated. See **radius ignore framed-ip-netmask**.
- You can enable **ppp ipcp netmask** either in a profile or on a static interface.

- Example

```
host1(config-subif)#ppp ipcp netmask
```

- Use the **no** version to disable IPCP option 0x90 option on the interface.

ppp keepalive

- Use to specify the keepalive timeout value.
- This command always operates in high-density keepalive mode if PPP is layered over ATM or PPPoE.
- When the keepalive timer expires, the interface first checks to see if any frames have been received from the peer in the prior keepalive timeout seconds. If so, it assumes that the peer is alive and well, and it does not send an LCP echo request (keepalive). Keepalive packets are sent only if the peer is silent (no traffic has been received from the peer during the previous keepalive timeout interval). If both sides are configured with keepalive, receipt of an LCP echo request by one end suppresses the transmission of an LCP echo request by that end.
- You can specify a timeout value from 30–300 seconds. The default value is 30 seconds.
- If the keepalive interval is 30 seconds, a failed link is detected between 9–120 seconds after failure.
- Example

```
host1(config-profile)#ppp keepalive 50
```

- Use **ppp keepalive** without a value to restore the default of 30 seconds.
- Use the **no ppp keepalive** to disable keepalive.

ppp log

- Use to enable PPP packet or state machine logging on any dynamic interface that uses the profile being configured. Specify one of the following keywords:
 - › **pppPacket** – enables PPP packet logging
 - › **pppStateMachine** – enables PPP state machine logging
- Example

```
host1(config-profile)#ppp log pppPacket
```



Note: This command is equivalent to the **log severity debug pppPacket** and **log severity debug pppStateMachine** commands.

- Use the **no** version to disable packet or state machine logging.

ppp magic-number disable

- Use to disable negotiation of the local magic number.
- Issuing this command prevents the system from detecting loopback configurations.
- Example

```
host1(config-profile)#ppp magic-number disable
```
- Use the **no ppp magic-number disable** command to restore negotiation of the local magic number.

ppp mru

- Use to control the negotiation of the maximum receive unit (MRU).
- You should coordinate this value with the network administrator on the other end of the line.
- If you set this value with a different value for another protocol, such as IP, the system uses the lower value. Using two different values could produce unexpected behavior in your network.
- The range is 64–65535.
- Example

```
host1(config-profile)#ppp mru 300
```
- Use the **no** version to restore the default value, which causes PPP to negotiate MRU based on the MRU of the layer immediately below PPP, less the PPP protocol overhead.

ppp multilink enable

- Use in a profile to enable the creation of dynamic MLPPP interfaces.
- Example

```
host1(config-profile)#ppp multilink enable
```
- Use the **no** version to cause the LNS to reject any incoming requests to create dynamic MLPPP interfaces.

ppp passive-mode

- Use to force a static or dynamic PPP interface into passive mode before LCP negotiation begins, for a period of one second. This delay enables slow clients to start up and initiate the LCP negotiation.
- Example

```
host1(config-if)#ppp passive-mode
```
- Use the **no** version to disable passive mode.

ppp peer

- Use to resolve conflicts when the system and the PPP peer system have the primary and secondary DNS and WINS addresses configured with different values.
- By default, the DNS and WINS addresses configured on the system take precedence.
- Use the **ppp peer dns** and/or the **ppp peer wins** commands to configure the PPP peer system as the one that takes precedence. The **ppp peer** command has no effect unless both systems have the address configured and the address is in conflict. If the PPP peer system has the address and the system does not, the peer always supplies the address regardless of how you have configured the PPP peer.
- Example

```
host1(config-profile)#ppp peer dns
```
- Use the **no ppp peer dns** and/or the **no ppp peer wins** commands when you want the system to take precedence during setup negotiations between the system and the remote PC client. If the IP addresses passed to the system by the remote PC client differ from the ones you have configured on your system, the system returns the values that you configured as the correct values to the remote PC client.

pppoe acName

- Use to add an access concentrator (AC) name to the profile configuration.
- Example

```
host1(config-profile)#pppoe acname CYM9876
```
- Use the **no** version to remove the AC name.

pppoe always-offer

- Sets up the system to offer to set up a session for the client, even if the system has insufficient resources to establish a session.
- This feature is disabled by default.
- Example

```
host1(config-profile)#pppoe always-offer
```
- Use the **no** version to disable this feature.

pppoe duplicate-protection

- Use to prevent a client from establishing more than one session using the same MAC address.
- This feature is disabled by default.
- Example

```
host1(config-profile)#pppoe duplicate-protection
```
- Use the **no** version to disable duplicate protection.

pppoe log pppoeControlPacket

- Use to enable packet trace logging on PPPoE dynamic interfaces created using this profile. Packet trace information is logged to the pppoeControlPacket log.
- Example

```
host1(config-profile)#pppoe log pppoeControlPacket
```
- Use the **no** version to turn off packet trace logging.

pppoe motm

- Use to cause the PPPoE application to send the string to the new client created when the profile is dynamically attached to an IP interface.
- The message *string* is saved in nonvolatile storage (NVS).
- Example

```
host1(config-profile)#pppoe motm string
```
- Use the **no** version to disable the command.

pppoe sessions

- Use to specify the maximum number of PPPoE subinterfaces permitted on an interface in the range 1–4094. The default value is 4094.
- Because the **sessions** command affects only the creation of subinterfaces, use of the **sessions** command affects only the creation of subinterfaces after the command is entered. Previously created interfaces remain, even if their number exceeds the new value of the **sessions** parameter.
- Example

```
host1(config-profile)#pppoe sessions 3000
```
- If you enable the pppoeControlPacket log at the debug level, the system sends a message when the session limit is reached.
- Example

```
host1(config)#log severity debug pppoecontrolpacket atm 3/0
```
- Use the **no** version to restore the default value, 4094.

pppoe url

- Use in a profile to cause the PPPoE application to send the string to the new client created when the profile is dynamically attached to an IP interface.
- The message *string* is saved in nonvolatile storage (NVS).
- PPPoE substitutes certain characters for information in the specified URL string before transmitting:
 - %U username and domain name
 - %u username
 - %d domain name
 - %D profile name
 - %% % character

- Example

```
host1(config-profile)#pppoe url http://www.relevanturl.com
```
- Use the **no** version to disable the command.

profile

- Use to create a profile.
- You specify a profile name with up to 80 characters.
- Example

```
host1(config)#profile foo
```
- Use the **no** version to remove a profile.

Assigning a Profile to an Interface

Use the **profile** command from Interface Configuration mode when you assign a profile to an interface.

For static PPP interfaces, you can assign only a profile for IP encapsulations. For static ATM 1483 subinterfaces, you can assign one profile for each Bridged Ethernet, IP, MLPPP, PPP, and PPPoE encapsulation. You can also use the default keyword **any**, which applies to any autoconfigured encapsulation that does not have specific profile assignment.

For example:

```
host1(config-subif)#profile any ProfileA
host1(config-subif)#profile ip ProfileB
```

In this example, *ProfileB* will be used if an IP packet is received, and *ProfileA* will be used for any other received encapsulation that is autoconfigured. When you omit the keyword, it defaults to **any**.

Follow this profile configuration example:

- 1 Configure a physical interface.

```
host1(config-if)#interface atm 2/1.10
```

- 2 Configure a PVC by specifying the VCD, the VPI, the VCI, and the encapsulation type.

```
host1(config-subif)#atm pvc 10 100 22 aal5snap
```

or

```
host1(config-subif)#atm pvc 10 100 22 aal5autoconfig
```

- 3 Apply an existing profile.

```
host1(config-subif)#profile ip holland
```

4 Assign subscriber identification.

```
host1(config-subif)subscriber ip user ispname domain abc.com  
password 3fds9jpt
```

5 Enable the dynamic encapsulation type.

```
host1(config-subif)#auto-configure ip
```

atm pvc

- Use to configure a PVC on an ATM interface. Select one of the following encapsulation options:
 - › **aal5autoconfig** – enables the autodetection of the 1483 encapsulation (LLC/SNAP or VC multiplexed).
 - › **aal5snap** – specifies a LLC encapsulated circuit; LLC/SNAP precedes the protocol datagram.
 - › **aal5mux ip** – specifies a VC multiplexed circuit. This option is used for IP only.
- Example

```
host1(config-subif)#atm pvc 6 0 11 aal5autoconfig
```
- Use the **no** version to remove the specified PVC.

auto-configure

- Use to configure an ATM subinterface to support a dynamic interface. Specifies the type(s) of dynamic encapsulation that will be accepted/detected by the ATM 1483 subinterface.
- This command creates the layers above ATM 1483 *dynamically*.
- Select the dynamic next upper interface type from these options: **bridgedEthernet, ip, ppp, or pppoe**
- You may enter the command repetitively to support multiple dynamic interface types.
- Example

```
host1(config-subif)auto-configure ip
```
- Use the **no** version to disable detection of the specified encapsulation.

profile

- Use to assign a profile to a static ATM 1483 or static PPP interface. The profile configuration is used to dynamically configure an upper bridged Ethernet, IP, PPP and/or PPPoE interface.
- **any** is the default encapsulation type and applies to any autoconfigured encapsulation that does not have a specific profile assignment.
- Example

```
host1(config-subif)#profile ip holland
```
- Use the **no** version to remove the assignment from the interface.

subscriber

- Use to configure a local subscriber on the ERX to support authentication and configuration from RADIUS for a dynamic IPoA or bridged Ethernet interface.
- When you configure a subscriber, you must specify the following:
 - › *interfaceType* – type of dynamic interface, **bridgedEthernet** or **ip**.
 - › *userNameUsage* – how the dynamic interface uses the username for authentication purposes
 - **user** – use the name as specified
 - **user-prefix** – use the name as a prefix to the interface physical location. The system automatically postpends the physical location of the user to the username string. The username format is *user.slot.port.vpi.vci*. The resulting username string is then used to be authenticated by the RADIUS server.
 - › *userName* – RADIUS username
 - › *domainName* – domain name
- You may optionally supply password information:
 - › *passwordUsage* – how the dynamic interface uses the password for authentication purposes
 - **password** – use the password as specified
 - **password-prefix** – use the password as a prefix to the interface physical location. The system automatically postpends the physical location of the user to the password string. The password format is *password.slot.port.vpi.vci*. The resulting password string is then used to authenticate with the RADIUS server.
 - › *password* – the RADIUS password
- Example

```
host1(config-subif)#subscriber ip user-prefix charlie domain
myisp password-prefix lucy
```
- Use the **no** version to remove the subscriber.

Profile Configuration Examples

Examples in this section show different ways that profiles can be configured.

- In this example, a new profile is configured with IP characteristics only.

```
host1(config)#profile ProfileA
host1(config-profile)#ip mtu 1024
host1(config-profile)#exit
```

- This example shows a new profile configured with both IP and PPP characteristics.

```
host1(config)#profile ProfileB
host1(config-profile)#ip mtu 512
host1(config-profile)#ppp authentication chap
host1(config-profile)#ppp keepalive 120
host1(config-profile)#exit
```

- This example shows a new profile configured with IP, PPP, and PPPoE characteristics.

```
host1(config)#profile ProfileC
host1(config-profile)#ip mtu 1400
host1(config-profile)#ppp authentication chap
host1(config-profile)#ppp keepalive 60
host1(config-profile)#pppoe sessions 64
host1(config-profile)#exit
```

- This example uses the profiles created in the previous three examples. It shows distinct profiles for each encapsulation, where the configuration of dynamic layers vary according to which incoming encapsulation the ATM 1483 subinterface detects.

```
host1(config)#interface atm 4/0.1
host1(config-subif)atm pvc 10 100 22 aal5autoconfig
host1(config-subif)#profile ip ProfileA
host1(config-subif)#profile ppp ProfileB
host1(config-subif)#profile pppoe ProfileC
host1(config-subif)#subscriber ip user atm1 domain isp1
password atmlpw
host1(config-subif)#auto-configure ip
host1(config-subif)#auto-configure ppp
host1(config-subif)#auto-configure pppoe
host1(config-subif)#exit
```

- This example also uses the three new profiles configured in the first three examples. It shows one profile being used for all encapsulations. The configuration of dynamic layers is the same regardless of incoming encapsulations detected by ATM. Only relevant profile attributes are used for whichever dynamic interface layers are actually constructed.

```

host1(config)#interface atm 4/0.2
host1(config-subif)atm pvc 200 0 200 aal5autoconfig
host1(config-subif)#profile any ProfileC
host1(config-subif)#subscriber ip user atm2 domain isp2
password atm2pw
host1(config-subif)#auto-configure ip
host1(config-subif)#auto-configure ppp
host1(config-subif)#auto-configure pppoe
host1(config-subif)#exit

```

- This example uses the three new profiles configured in the first three examples, and is implicitly assigned via the **any** encapsulation wildcard. Note that configuration of dynamic layers is the same regardless of incoming encapsulation detected by ATM.

```

host1(config)#interface atm 4/0.3
host1(config-subif)atm pvc 300 0 300 aal5autoconfig
host1(config-subif)#profile any ProfileC
host1(config-subif)#subscriber ip user atm2 domain isp3
password atm3pw
host1(config-subif)#auto-configure ip
host1(config-subif)#auto-configure ppp
host1(config-subif)#auto-configure pppoe
host1(config-subif)#exit

```

- This example uses the profile configured in the first example.

```

host1(config)#interface atm 4/0.3
host1(config-subif)atm pvc 300 0 300 aal5autoconfig
host1(config-subif)#profile bridgedEthernet ProfileA
host1(config-subif)#subscriber bridgedEthernet user atm3
domain isp1 password fjdkei
host1(config-subif)#auto-configure bridgedEthernet

```

Monitoring Dynamic Interfaces and Profiles

You can monitor interface columns using the **show columns** command, and you can display your profile configuration using the **show profile** command.

show columns

- Displays counts of static and dynamic interfaces for each interface column.
- Counts for PPP and PPPoE interface columns are updated when the PPP layer comes up.
- Counts for bridged Ethernet and IP over ATM columns are updated when the ATM layer comes up.

- Field descriptions
 - › Type – interface type
 - › Total – total number of interfaces on this column
 - › Static – number of static interfaces on this column
 - › Dynamic – number of dynamic interfaces on this column
- Example

```

host#show columns
                                Interface columns:
                                -----
                                Type           Total      Static     Dynamic
                                -----
Bridged Ethernet                4           2           2
IP over ATM                      4           2           2
PPP                              22          12          10
PPPoE                            10           5           5

```

show profile

- Use to display information about profiles.
- Use the **name** keyword to display information about a specific profile.
- Use the **brief** keyword to display a list of profiles configured on the router.
- Field descriptions
 - › Profile – name of the profile that is displayed
 - › IP address – IP address and subnet mask of the interface or none if the interface is unnumbered
 - › Router – name of the VR assigned to the profile; interfaces created by the profile are attached to this VR
 - › Directed Broadcast – enabled or disabled
 - › ICMP Redirects – enabled or disabled
 - › Access Route Addition – enabled or disabled
 - › Source-Address Validation – enabled or disabled
 - › Ignore DF Bit – enabled or disabled
 - › Administrative MTU – MTU size configured on the profile
 - › IGMP – enabled or disabled
 - › static-groups – displays any static groups configured for IGMP
 - › Input policy – name of input policy and whether statistics are enabled or disabled
 - › Output policy – name of output policy and whether statistics are enabled or disabled
 - › PPP Keepalive – enabled or disabled
 - › PPP Magic Number – enabled or disabled
 - › PPP Peer DNS Priority – enabled or disabled
 - › PPP Peer WINS Priority – enabled or disabled
 - › PPP Authentication – type of authentication configured: PAP, CHAP, none

- › PPP Authentication Router – name of authentication virtual router
 - › PPP Negotiate MRU – MRU configured for the profile
 - › PPP Packet Log – enabled or disabled
 - › PPP State Log – enabled or disabled
 - › PPP Chap Challenge Length – minimum and maximum Chap Challenge length
 - › PPP Passive Mode – enabled or disabled
 - › PPP Multilink – enabled or disabled
 - › PPP IPCP netmask option – enabled or disabled
 - › PPPoE Max Sessions – maximum number of PPPoE subinterfaces permitted on an interface
 - › PPPoE Always-offer – enabled, disabled
 - › PPPoE ACNAME – access concentrator name
 - › PPPoE Log PPPoEControlPacket – enabled, disabled
 - › PPPOE duplicate-protect – enabled, disabled
 - › PPPoE URL – URL sent in PADM message to PPPoE clients
 - › PPPoE MOTM – message of the minute sent in the PADM message to PPPoE clients
- Example

```

host1#show profile name rige14
Profile                               : rige14
IP address : 10.1.23.23/255.255.255.0
Router                                 :
Directed Broadcast                    : Disabled
ICMP Redirects                        : Disabled
Access Route Addition                 : Enabled
Source-Address Validation              : Disabled
Ignore DF Bit                          : Enabled
Administrative MTU                     : 1024

IGMP                                   : Enabled
  static-groups                        :
  Input policy:  bobb statistics enabled
  Output policy: bobb statistics enabled
PPP Keepalive                          : 30
PPP Magic Number                       : disabled
PPP Peer DNS Priority                   : enabled
PPP Peer WINS Priority                  : disabled
PPP Authentication                     : chap/pap
PPP Authentication Router               : 'unisp'
PPP Negotiate MRU                      : 65535
PPP Packet Log                         : disabled
PPP State Log                          : disabled
PPP Chap Challenge Length               : 16 - 32

```

```
PPP Passive Mode           : disabled
PPP Multilink              : disabled
PPP IPCP netmask option   : enabled
PPPoE Max Sessions        : 8000
PPPOE Always-offer        : Enabled

PPPoE ACNAME               : cny123

PPPoE Log PPPoEControlPacket: Enabled
PPPOE duplicate-protect    : Enabled
PPPoE URL                  : www.juniper.net
PPPoE MOTM                 : goodmorning
```

Scripts and Macros

Scripts and macros are intended to reduce the management of static interfaces. Because dynamic interfaces have static lower layers, scripts and/or macros can be used to configure the static portion of all dynamic interfaces.

A script or macro can specify the static interface via the **interface**, **auto-configure**, **subscriber**, or **profile** commands. These commands allow you to configure the interface as dynamic and to specify configuration sources for the dynamic upper layers. These files can then be executed by the ERX system as though the commands were entered at the terminal.

- **Scripts** – You can create script files containing a series of CLI commands. The resulting script can be executed via the **configure file** command.
- **Macros** – You can create macros that will generate and execute CLI commands. You first write macros on a computer and then copy them to your ERX system. You issue the **macro** command from the CLI to execute both local macros or macros stored remotely. The **macro** command is available from all ERX system command modes. See *ERX System Basics Configuration Guide, Chapter 7, Writing CLI Macros*.



Note: For a list of vendor-specific attributes (VSAs) that apply to dynamic interfaces, see *ERX Broadband Access Configuration Guide, Chapter 1, Configuring Remote Access to the ERX System*.

