

# 5

## Managing Line Modules and SRP Modules

This chapter describes how to manage line modules and SRP modules in the ERX system.

Topic	Page
Overview	5-1
Disabling and Reenabling Modules	5-2
Removing an SRP Module	5-2
Replacing Line Modules	5-4
Replacing SRP Modules	5-5
Software Compatibility	5-5
Configuring Performance Rate of Line Modules	5-6
Line Module Redundancy	5-14
SRP Module Redundancy	5-19
Managing NVS Cards on SRP Modules	5-24
Managing the Ethernet Port on the SRP Module	5-31
Monitoring Modules	5-33

### Overview

---

When managing line modules and SRP modules, you need to consider both software and hardware procedures. For example, before you remove an SRP module, you must enter the **halt** command to prevent damage to nonvolatile storage (NVS).

This chapter describes the software issues associated with managing modules. Each section in the chapter covers a different topic; where

appropriate, a section contains an overview of the topic, configuration tasks, and information about monitoring the associated settings.

The *ERX Installation and User Guide* contains information about related procedures. For information about installing modules, see *ERX Installation and User Guide, Chapter 3, Installing ERX Modules*. For information about upgrading software on SRP modules, see *ERX Installation and User Guide, Appendix E, Installing ERX System Software*.

## Disabling and Reenabling Modules

---

Disabling a line module or SRP module has the same effect as removing that module from a slot. A disabled module cannot operate, although its configuration remains in NVS. To allow the module to operate, you must reenabling it.

### **slot disable**

- Use to disable the line module or SRP module in the specified slot.
- You can use this command to disable a module so that you can run diagnostic tests on the module.
- Example

```
host1(config)#slot disable 3
```
- There is no **no** version.

### **slot enable**

- Use to enable the line module or SRP module in the specified slot.
- Allows you to restart the module that was installed in the slot.
- The default is enable.
- Example

```
host1(config)#slot enable 3
```
- There is no **no** version.

## Removing an SRP Module

---

Before you remove an SRP module, you must issue the **halt** command, which stops operation on that module. If the system contains both primary and redundant SRP modules, you can specify which modules the command should affect. You can also configure the system to prompt you if the modules are in a state that could lead to loss of configuration data or NVS corruption.



**Caution:** If you do not use the **halt** command before removing or powering down an SRP module, the system's NVS may become corrupted.

For information about physically removing an SRP module, see *ERX Installation and User Guide, Chapter 3, Installing ERX Modules*.

### **halt**

- Use to stop the system's operation before you remove or power down an SRP module.
- Specify neither the **primary** nor the **secondary** keyword to stop operation on both SRP modules.
- Specify the keyword **primary** to stop operation on the primary SRP module only. This action causes the redundant SRP module to assume the primary role.
- Specify the keyword **secondary** to stop operation on the redundant SRP module only.
- If you specify the **force** keyword, the procedure will fail if the SRP modules are in certain states, such as during a synchronization. In these cases, the system will display a message that indicates that the procedure cannot currently be performed and the reason why. However, if the SRP modules are in other states that could lead to a loss of configuration data or NVS corruption, the system displays a message that explains the state of the SRP modules and asks you to confirm (enter yes or no) whether you want to proceed.
- If you do not specify the **force** keyword, the procedure will fail if the SRP modules are in any state that could lead to loss of configuration data or NVS corruption, and the system will display a message that explains why the command failed.
- When you issue this command, the system prompts you for a confirmation before the procedure starts.
- Remove or power down the SRP module within 2 minutes of executing the **halt** command. Otherwise, the SRP module will automatically reboot.

- Examples

```
host1#halt
host1#halt primary
host1#halt standby force
```

- There is no **no** version.

## Replacing Line Modules

---

When you configure a line module, the system stores the configuration in NVS. If you plan to install modules in slots previously occupied by different types of modules—for example, an FE-2 line module and a FE-2 I/O module in slots that previously contained a CT3 line module and a CT3/T3 I/O module—you must do one of the following:

- Before installing the different type of module, issue the **slot erase** command.
- After installing the different type of module, issue the **slot accept** command.

### **slot accept**

- Use to delete the configuration of the line module in the selected slot after you install a different type of line module.
- This command allows you to create a fresh configuration for the module installed in the slot.
- You can also use this command to accept an empty slot that was previously occupied.
- Depending on the slot's previous configuration, this system may take a few moments to execute this command.
- The following is a sample Log message resulting from putting an OC3 line module in a slot that was previously configured for a CT3 line module:

```
ERROR 04/05/1999 07:50:32 system (slot 4): boardid mismatch:  
  read 0x5 (OC3 single port), configured 0x7 (Channelized  
  T3)
```

To resolve the problem, issue the **slot accept** command for slot 4.

- Example  

```
host1(config)#slot accept 4
```
- There is no **no** version.

### **slot erase**

- Use to delete the configuration of the line module in the selected slot before you install a different type of line module.
- This command allows you to create a fresh configuration for the module installed in the slot.
- Example  

```
host1(config)#slot erase 3
```
- There is no **no** version.

## Replacing SRP Modules

---

If you perform one of the following actions, you must reset the configuration of the system to factory default:

- Replace a 5-Gbps SRP module with a 10-Gbps SRP module or vice versa.
- Transfer an SRP module from an ERX-700 system to an ERX-1410 system or vice versa.

You cannot use the **slot accept** command to force the system to accept the new SRP module.

When you have installed the SRP module in the new location, reset the configuration of the system to factory defaults as follows:

- 1 Reload the operating system, then press <mb> key sequence (case-insensitive) during the countdown.

```
host1#reload
```

- 2 Reboot the system with the factory defaults.

```
:boot##boot config factory-defaults
```

- 3 Reload the operating system.

```
:boot##reload
```

## Software Compatibility

---

An ERX software release supports a specific set of line modules and I/O modules. Before you install a new line module or I/O module, you should install a software release that supports the new module.

### *Line Modules*

If the system uses a software version that does not support a line module that you install, you see the message “unrecognized board type,” and the system disables the module. When you issue a **show version** command, the state of the line module is *disabled (admin)*.

If you subsequently boot the system with software that supports the line module, the line module becomes available and its state is *enabled*.

## I/O Modules

If the system uses a software version that does not support an I/O module that you install, the I/O module will be unavailable, and you will not be able to upgrade the software on the system. To upgrade the software:

- 1 Remove the I/O module.
- 2 Reboot the line module that corresponds to this I/O module. See *ERX System Basics Configuration Guide, Chapter 8, Booting the System*.
- 3 When the line module has rebooted, install the I/O module.
- 4 Upgrade the software on the system. See *ERX Installation and User Guide, Appendix E, Installing ERX System Software*.

## Configuring Performance Rate of Line Modules

---



**Note:** This section does not apply to the ERX-1440 system.

Line modules in an ERX-1440 system always operate at line rate performance. However, you can configure the ERX-700 series and the ERX-1410 system to enable the line modules either to operate at full line rate performance or to allow line modules to operate at a rate dependent on the resources available.

Operating at full line rate performance restricts the combination of line modules in the system. Operating at a rate dependent on the resources available allows a much more extensive combination of line modules in the system and is known as *bandwidth oversubscription*.

To configure performance, complete the following steps:

- 1 Choose a combination of line modules appropriate for the performance. See *Choosing a Combination of Line Modules*, later in this chapter.
- 2 Disable slots that contain unwanted line modules or modify the combination of line modules in the system. See *Disabling and Reenabling Modules*, earlier in this chapter, and *ERX Installation and User Guide, Chapter 3, Installing ERX Modules*.
- 3 Specify the type of performance. See *Specifying the Type of Performance*, later in this chapter.

### Choosing a Combination of Line Modules

For line rate performance, the total bandwidth required by the line modules in the slot group must not exceed the bandwidth available from

the SRP module. In this case, the combination of line modules that can reside in a slot group depends on the following:

- Restrictions on certain combinations of line modules
- The number of slots per group
- The bandwidth available from the SRP module
- The bandwidth required by each line module
- In the case of the SRP-5G+ and SRP-10G modules, the switches (upper and lower) that the line module can use.

#### Restricted Line Module Combinations

The following restrictions on line modules apply:

- The SRP-5G module does not support the cOCx/STMx, CT3 12, COCX-F3, GE/FE, IPsec Service, OCx/STMx or TSM line modules.
- The SRP-5G+ and SRP-10G modules do not support OC3 (dual port) line modules in the same slot group as cOCx/STMx, CT3 12, COCX-F3, GE/FE, IPsec Service, OCx/STMx POS or TSM line modules.
- In bandwidth oversubscription mode, the SRP-5G+ and SRP-10G modules do not support an OC3 (dual port) line module in the same slot group as an OCx/STMx ATM line module.

However, in non-bandwidth oversubscription mode, the SRP-5G+ and SRP-10G modules support one OC3 (dual port) line module and one OCx/STMx ATM line module in the same slot group.

#### Slot Groups

The number of slots in a group depends on the ERX model. For information about slot groups, see *ERX Installation and User Guide, Chapter 3, Installing ERX Modules*.

### SRP Modules Bandwidth

Different SRP modules offer different bandwidths:

- The SRP-5G module provides 1.25 Gbps bandwidth per slot group.
- The SRP-10G module provides 2.5 Gbps bandwidth per slot group.
- The SRP-5G+ module (ERX-705 system only) provides:
  - > 2.5 Gbps bandwidth per slot group
  - > 5 Gbps bandwidth per system

### Line Modules Bandwidth and Switch Usage

The SRP-5G module has one switch that supplies 100% of the bandwidth for line modules. However, the SRP-5G+ and SRP-10G modules comprise two switches; each switch provides 50% of the bandwidth. The line modules in a slot group cannot operate at line rate if:

- The sum of their bandwidths exceeds the bandwidth that the SRP module can supply per slot group.
- The sum of the bandwidths they require from one SRP switch exceeds the bandwidth that the SRP switch can supply per slot group.

For example, the T3 line module requires 0.54 Gbps bandwidth and uses only the top switch of the SRP-10G module. To operate three T3 line modules in a slot group at line rate, you would need 1.62 Gbps bandwidth from the top switch. The top switch of the ERX-1410 system offers 1.25 Gbps bandwidth per slot group. Three T3 line modules cannot operate at line rate with an SRP-10G module.

Table 5-1 shows the bandwidth that each line module requires for line rate performance and the switches that the line module can use on the SRP-5G+ and SRP-10G modules.

**Table 5-1** Bandwidth statistics for line modules

Line Module	Total Bandwidth Required (Gbps)	Switches Used on SRP-5G+ and SRP-10G Modules
CE1	0.20	Top switch only
cOCx/STMx	2.46	Both switches <sup>a</sup>
COCX-F3	2.46	Both switches <sup>a</sup>
CT1	0.20	Top switch only
CT3	0.54	Top switch only
CT3/T3 FO	2.46	Both switches <sup>a</sup>
E3	0.54	Top switch only

**Table 5-1** Bandwidth statistics for line modules (continued)

Line Module	Total Bandwidth Required (Gbps)	Switches Used on SRP-5G+ and SRP-10G Modules
FE-2	0.52	Either switch
GE/FE	2.46	Both switches <sup>a</sup>
HSSI	0.54	Top switch only
IPSec Service	2.46	Both switches <sup>a</sup>
OC3 (dual port)	1.2	Either switch
OCx/STMx ATM	1.22	Both switches <sup>a</sup>
OCx/STMx POS	2.46	Both switches <sup>a</sup>
T3	0.54	Top switch only
TSM	2.46	Both switches <sup>a</sup>
X.21/V.35	0.20	Top switch only

a In bandwidth oversubscription mode, 50% per switch; in non-bandwidth oversubscription mode, up to 100% per switch

#### Allowed Combinations for Line Rate Performance

Table 5-2 shows a list of combinations of line modules that allow line rate performance. However, if performance lower than line rate is acceptable, you can use any combination of line modules (other than the restricted combinations) in a slot group.

For example, the SRP-10G module offers a total bandwidth of 2.5 Gbps for each slot group. The GE line module requires 2.46 Mbps bandwidth for operation at line rate, and can use both switches in the SRP-10G module. If you require line rate from a GE line module, install only one GE line module in the slot group. However, if lower performance is acceptable, you can install two or three GE line modules in a slot group and enable bandwidth oversubscription.

When bandwidth oversubscription is enabled, all line modules, except the OC3 (dual port) and FE-2 line modules, optimize use of the resources available. For example, if two GE line modules are installed in a slot group, each line module is allocated 50% of the available bandwidth. However, if one line module is using less bandwidth than it is allocated, the other line module can use more bandwidth than it is allocated and can operate at a greater line rate. The OC3 (dual port) and FE-2 line modules use a fixed portion of the available bandwidth; they cannot take advantage of resources unused by other line modules.

To ensure the best performance, when you change line modules in a slot group that contains FE-2 or OC3 (dual port) line modules, you should optimize the bandwidth. See *Optimizing Bandwidth*, later in this chapter.

**Table 5-2** Combinations of line modules for line rate performance

<b>SRP Module and System</b>	<b>Possible Combinations of Line Modules</b>
SRP-5G in ERX-700 system	<ul style="list-style-type: none"> <li>• One CE1, CT1, CT3, E3, FE-2, HSSI, OC3 (dual port), T3, or X.21/V.35 line module, and one empty slot in slot group 1</li> <li>• Two CE1, CT1, CT3, E3, FE-2, HSSI, T3, or X.21/V.35 line modules in any combination in slot group 1</li> <li>• One CE1, CT1, CT3, E3, FE-2, HSSI, OC3 (dual port), T3, or X.21/V.35 line module in slot groups 2, 3, and 4</li> <li>• No cOCx/STMx, COCX-F3, CT3/T3 FO, GE/FE, IPsec Service, or OCx/STMx line modules or TSMs.</li> </ul> <p><b>Examples of combinations that allow line rate performance</b></p> <ul style="list-style-type: none"> <li>• Two CT1 line modules in slot group 1, one CT3 line module in slot group 2, OC3 (dual port) line modules in slot groups 3 and 4</li> <li>• One CE1 and one E3 line module in slot group 1, one HSSI module in slot group 2, one FE-2 module in slot group 3, and one OC3 (dual port) line module in slot group 4</li> </ul> <p><b>Examples of combinations that do not allow line rate performance</b></p> <ul style="list-style-type: none"> <li>• Two OC3 (dual port) line modules in slot group 1</li> <li>• An OCx/STMx line module in any slot group</li> </ul>
SRP-10G in ERX-700 system	<ul style="list-style-type: none"> <li>• One of any supported line module and one empty slot in slot group 1</li> <li>• One OCx/STMx ATM line module and one CE1, CT1, CT3, E3, FE-2, HSSI, OC3 (dual port), T3, or X.21/V.35 line module in slot group 1</li> <li>• Two OCx/STMx ATM line modules in slot group 1</li> <li>• Two CE1, CT1, CT3, E3, FE-2, HSSI, OC3 (dual port), T3, or X.21/V.35 line modules in any combination in slot group 1</li> <li>• One CE1, cOCx/STMx, COCX-F3, CT1, CT3, CT3/T3 FO, OC3 (dual port), E3, FE-2, GE/FE, HSSI, IPsec Service, OCx/STMx, T3, or X.21/V.35 line module or one TSM line module in slot groups 2, 3 or 4</li> </ul> <p><b>Examples of combinations that allow line rate performance</b></p> <ul style="list-style-type: none"> <li>• Two CT1 line modules in slot group 1, one CT3 line module in slot group 2, an OCx/STMx POS line module in slot group 3, and a HSSI module in slot group 4</li> <li>• One CE1 and one E3 line module in slot group 1, one HSSI module in slot group 2, one FE-2 module in slot group 3, and one OC3 (dual port) line module in slot group 4</li> </ul> <p><b>Examples of combinations that do not allow line rate performance</b></p> <ul style="list-style-type: none"> <li>• A GE/FE line module and any other line module in slot group 1</li> <li>• Two OCx/STMx line modules in slot group 1</li> </ul>

**Table 5-2** Combinations of line modules for line rate performance (continued)

SRP Module and System	Possible Combinations of Line Modules
SRP-10G in ERX-1410 system	<ul style="list-style-type: none"> <li>• One of any supported line module and two empty slots in any slot group</li> <li>• One OC3 (dual port) line module and one or two CE1, CT1, CT3, E3, HSSI, T3, or X.21/V.35 line modules in any combination in any slot group</li> <li>• One OC3 (dual port) line module and one FE-2 line module in any slot group</li> <li>• One OCx/STMx ATM line module and one or two CE1, CT1, FE-2, or X.21/V.35 line modules in any combination in any slot group</li> <li>• One OCx/STMx ATM line module and one CT3, E3, HSSI, or T3 line module and one empty slot in any slot group</li> <li>• Two OCx/STMx ATM line modules and one empty slot in any slot group</li> <li>• Two CE1, CT1, CT3, E3, FE-2, HSSI, OC3 (dual port), T3, or X.21/V.35 line modules in any combination and one empty slot in any slot group</li> <li>• Two CT3, E3, HSSI, or T3 line modules and one CE1, CT1, FE-2, or X.21/V.35 line module in any combination in any slot group</li> <li>• One CT3, E3, HSSI, or T3 line module and two CE1, CT1, FE-2, or X.21/V.35 line modules in any combination in any slot group</li> <li>• Three CE1, CT1, FE-2, or X.21/V.35 line modules in any combination in any slot group</li> </ul> <p><b>Examples of combinations that allow line rate performance</b></p> <ul style="list-style-type: none"> <li>• Two OC3 (dual port) line modules in slot group 1, a GE/FE line module in slot group 2, three CT1 line modules in slot group 3, and two T3 Frame line modules in slot group 4</li> <li>• Two CE1 and one E3 line modules in slot group 1, two HSSI modules in slot group 2, an OCx/STMx POS line module in slot group 3, and a GE/FE line module in slot group 4</li> </ul> <p><b>Examples of combinations that do not allow line rate performance</b></p> <ul style="list-style-type: none"> <li>• Three OC3 (dual port) line modules in any slot group</li> <li>• Two OCx/STMx POS line modules in any slot group</li> </ul>

**Table 5-2** Combinations of line modules for line rate performance (continued)

SRP Module and System	Possible Combinations of Line Modules
SRP-5G+ in ERX-705 system	<p><b>Note:</b> <i>The total bandwidth of all line modules must not exceed 5 Gbps. To make optimal use of the available bandwidth, put line modules that require maximum bandwidth in slots 2, 3, or 4.</i></p> <ul style="list-style-type: none"> <li>• One of any supported line module and one empty slot in slot group 1</li> <li>• One OCx/STMx ATM line module and one CE1, CT1, CT3, E3, FE-2, HSSI, OC3 (dual port), T3, or X.21/V.35 line module in slot group 1</li> <li>• Two OCx/STMx ATM line modules in slot group 1</li> <li>• Two CE1, CT1, CT3, E3, FE-2, HSSI, OC3 (dual port), T3, or X.21/V.35 line modules in any combination in slot group 1</li> <li>• One CE1, cOCx/STMx, COCX-F3, CT1, CT3, CT3/T3 FO, OC3 (dual port), E3, FE-2, GE/FE, HSSI, IPsec Service, OCx/STMx, T3, or X.21/V.35 line module or one TSM in slot groups 2, 3 or 4</li> </ul> <p><b>Examples of combinations that allow line rate performance</b></p> <ul style="list-style-type: none"> <li>• Two OCx/STMx ATM line modules (total 2.44 Gbps) in slot group 1 and a GE/FE line module (2.46 Gbps) in slot group 4</li> <li>• Two OCx/STMx ATM line modules (total 2.44 Gbps) in slot group 1, a HSSI module (0.54 Gbps) in slot group 2, a CT3 3 line module (0.54 Gbps) in slot group 3, and a T3 Frame (0.54 Gbps) line module in slot group 4</li> </ul> <p><b>Examples of combinations that do not allow line rate performance</b></p> <ul style="list-style-type: none"> <li>• Two OCx/STMx ATM line modules (total 2.44 Gbps) in slot group 1, a GE/FE line module (2.46 Gbps) in slot group 3, and an OCx/STMx POS line module (2.46 Gbps) in slot 4 (violates chassis limitation)</li> <li>• Two OCx/STMx POS line modules (total 4.92 Gbps) in slot group 1 (violates slot group limitation)</li> </ul>

### Specifying the Type of Performance

After you have installed a suitable combination of line modules, you must specify the type of performance. To specify the type of performance:

- 1 Issue the **show bandwidth oversubscription** command.
- 2 If the setting is not the one you want, enable or disable bandwidth oversubscription.
- 3 Reboot the system.

### ***bandwidth oversubscription***

- Use to enable bandwidth oversubscription for an ERX-700, ERX-705, or ERX-1410 system. Reboot the system after you have issued this command to change the bandwidth oversubscription status.
- By default, bandwidth oversubscription is enabled.
- Example  

```
host1#bandwidth oversubscription
```
- Use the **no** version to disable bandwidth oversubscription. Reboot the system after you have issued this command to change the bandwidth oversubscription status.

### *Monitoring Bandwidth Oversubscription*

Use the **show bandwidth oversubscription** and **show utilization** (see *Monitoring Modules*, later in this chapter) commands to monitor the status of bandwidth oversubscription.

### ***show bandwidth oversubscription***

- Use to display the bandwidth oversubscription status for an ERX-700, ERX-705, or ERX-1410 system.
- Example 1: This example shows the display when bandwidth oversubscription is enabled.  

```
host1#show bandwidth oversubscription  
Bandwidth oversubscription is currently in effect.
```
- Example 2: This example shows the display that appears after you issue the **no bandwidth oversubscription** command to disable bandwidth oversubscription.  

```
host1#no bandwidth oversubscription  
host1#show bandwidth oversubscription  
Bandwidth oversubscription is currently in effect.  
Bandwidth oversubscription will not be in effect the next  
time the system reboots.
```
- Example 3: This example shows the display when bandwidth oversubscription is disabled.  

```
host1#show bandwidth oversubscription  
Bandwidth oversubscription is currently not in effect.
```
- Example 4: This example shows the display that appears after you issue the **bandwidth oversubscription** command to enable bandwidth oversubscription.  

```
host1#bandwidth oversubscription  
host1#show bandwidth oversubscription  
Bandwidth oversubscription is currently not in effect.  
Bandwidth oversubscription will be in effect the next time  
the system reboots.
```

## Troubleshooting

If you enter a forbidden combination of line modules or exceed the slot group bandwidth when you have not configured bandwidth oversubscription, you will see an error message.

For example, suppose you originally configure the system for bandwidth oversubscription and then want to change to full line rate performance. You forget to remove line modules or disable slots, and enter the **no bandwidth oversubscription** command. The following message appears:

```
host1(config)#no bandwidth oversubscription
% failed : bandwidth over subscribed at slot 0-2
```

To resolve the problem, remove the unwanted line modules, or disable the slots that contain those line modules.

## Optimizing Bandwidth

If you change line modules in a quadrant that contains FE-2 or OC3 (dual port) line modules, issue the **reload slot** command on the slots that contain the FE-2 or OC3 (dual port) line modules. This action optimizes the bandwidth in the quadrant. If you do not optimize the bandwidth, the line modules in the quadrant may not operate at the optimal rate or may be disabled.

If a line module is disabled because of insufficient bandwidth, when you issue the **show version** commands, the description “disabled (cfg error)” appears in the display for the affected modules. In addition, depending on the log configuration, the following message may appear on the console:

```
Line card in slot xx is disabled because of lack of fabric
bandwidth in the quadrant
```

## Line Module Redundancy

---

You can install an extra line module in a group of identical line modules to provide redundancy if one of the modules fails. To use this feature, you must also install a redundancy midplane and a redundancy I/O module. For a detailed explanation of how the system provides redundancy for line modules and procedures for installing the modules, see the *ERX Installation and User Guide*.

The process by which the system switches to the spare line module is called *switchover* or *failover*. During switchover, the line, circuit, and IP interfaces on the I/O module appear to go down temporarily. The duration of the downtime depends on the number of interfaces and the size of the

routing table, because the system must reload the interface configuration and the routing table from the SRP module.

If the line module software is not compatible with the running SRP module software release, a warning message appears on the console.

### *Automatic Switchover*

Provided you have not issued the **redundancy lockout** command for the primary line module, the system switches over to the spare line module automatically if it detects any of the following failures on the primary line module:

- Power-on self-test (POST) failure
- Software-detected unrecoverable error
- Software watchdog timer expiration
- Primary line module failure to respond to keepalive polling from the SRP module
- Removal, disabling, or reloading of the primary line module
- Missing or disabled primary line modules when the system reboots
- Resetting the primary line module via the concealed push button

### Limitations of Automatic Switchover

If automatic switchover is enabled on a slot (the default configuration) and a spare line module is available, issuing some CLI commands for the primary line module causes a switchover (see Table 5-3).

You can also disable automatic switchover on individual slots. See *Configuring Line Module Redundancy*, later in this chapter.

**Table 5-3** Commands that can cause automatic switchover

Command	Reason for Automatic Switchover
<b>slot disable</b> <primary-line-module-slot>	The command disables the primary line module but not the primary I/O module.
<b>reload slot</b> <primary-line-module-slot>	The command is equivalent to pushing the reset button on the primary line module.

### *Reversion after Switchover*

You can install only one spare line module in the group of slots covered by the redundancy midplane. If the system is using the spare line module, no redundancy is available. It is desirable to revert to the primary module as soon as possible. By default, the system does not automatically revert to the primary module after switchover; however, you can configure it to do so. (See *Configuring Line Module Redundancy*, later in this chapter.) Before reversion can take place, the primary line module must complete the POST diagnostics.

### *Configuring Line Module Redundancy*

You can modify the default redundancy operations on the system as follows:

- Disable automatic switchover on a slot.
- Enable automatic reversion after switchover.

#### ***redundancy lockout***

- Use to prevent the system from switching automatically to a spare line module if the primary module in the specified slot fails.
- The **redundancy force-failover** command overrides the **redundancy lockout** command.
- Example

```
host1(config)#redundancy lockout 5
```
- Use the **no** version to restart redundancy protection for the slot.

#### ***redundancy revertive***

- Use to enable the system to revert from all spare line modules to the associated primary line modules automatically.
- Reversion takes place when the primary line module is once again available unless you specify a time of day. In that case, reversion takes place only when the primary module is available and after the specified time.
- Example

```
host1(config)#redundancy revertive 23:00:00
```
- Use the **no** version to disable automatic reversion.

### *Managing Line Module Redundancy*

When the system is running and a redundancy group is installed, you can manage the redundancy situation as follows:

- Force switchover manually.
- Force reversion manually.

### **redundancy force-failover**

- Use to force the system to switch from the primary line module in the specified slot to the spare line module.
- The command causes a single switchover. When you reboot, the system will revert to the configured setting for this slot.
- The **redundancy force-failover** command overrides the **redundancy lockout** command.
- Example  

```
host1#redundancy force-failover 5
```
- There is no **no** version.

### **redundancy revert**

- Use to force the system to revert to the primary line module in the specified slot.
- The system acts on this command immediately unless you specify a time or a time and date that the action is to take place.
- The command causes a single reversion. When you reboot, the system uses the configured setting for this slot.
- Example  

```
host1#redundancy revert 4 23:00:00 5 September 200X
```
- There is no **no** version.

## *Monitoring Line Module Redundancy*

You can use **show** commands to monitor the status of redundancy groups and line modules.

### **show environment**

- Use to display information about the hardware installed for redundancy.
- See *ERX System Basics Configuration Guide, Chapter 4, Managing the System*, for details and examples.

### **show hardware**

- Use to display detailed information about the line modules and SRP modules.
- See *Monitoring Modules*, later in this chapter, for details and examples.

**show redundancy**

- Use to display the configuration for line module redundancy.
- Field descriptions
  - › slot – slot in which the line module resides
  - › hardware role – function of the line module: primary or spare
  - › redundancy midplane type – identifier for the type of midplane
  - › redundancy midplane rev – hardware revision number of the redundancy midplane
  - › lockout config – status of redundancy on this line module
    - protected – line module redundancy is enabled
    - locked out – line module redundancy is disabled
  - › backed up by slot – slot that contains the line module that is a spare for this primary line module
  - › sparing for slot – slot that contains the primary line module for which this line module is a spare
- Example

In the following example, the user issues a **show redundancy** command, then a **force failover** command. Finally, the user issues another **show redundancy** command. The two displays show how the states of the primary and spare line modules change.

```
host1#show redundancy
  automatic reverting is off
```

slot	hardware role	redundancy midplane type	midplane rev	lockout config	backed up by slot	sparing for slot
2	---	---	---	---	---	---
6	---	---	---	---	---	---
8	spare	6	0	---	---	---
9	primary	6	0	protected	---	---

```
host1#redundancy force-failover 9
```

```
host1#show redundancy
  automatic reverting is off
```

slot	hardware role	redundancy midplane ID	midplane rev	lockout config	backed up by slot	sparing for slot
2	---	---	---	---	---	---
6	---	---	---	---	---	---
8	spare	6	0	---	---	9
9	primary	6	0	protected	8	---

**show version**

- Use to display information about each module in the system.
- See *ERX System Basics Configuration Guide, Chapter 4, Managing the System*, for details and examples.

## SRP Module Redundancy

---

This section covers general issues of SRP module redundancy. For information about managing NVS in a system that contains two SRP modules, see *Managing NVS Cards on SRP Modules*.

The SRP module uses a 1:1 redundancy scheme. When two SRP modules are installed in the system, one acts as a primary and the second as a redundant module. Both SRP modules share a single SRP I/O module located in the rear of the chassis.

After you install two SRP modules, the modules negotiate for the primary role. A number of factors determine which module becomes the primary; however, preference is given to the module in the lower slot. The SRP modules record their latest roles and retain them the next time you switch on the system.

With the default software settings, if the primary SRP module fails, the redundant SRP module assumes control without rebooting itself. For information about preventing the redundant SRP module from assuming control, see *Managing Line Module Redundancy*, earlier in this chapter.

When the redundant SRP module assumes control, the following sequence of events occurs:

- 1 The original primary SRP module reboots and assumes the redundant role.
- 2 The redundant SRP module restarts and assumes the primary role without reloading new code. (When upgrading software, you must reload the software on the redundant SRP module. See *ERX Installation and User Guide, Appendix E, Installing ERX System Software*.)
- 3 All line modules reboot.

The following actions activate the redundant SRP module:

- Failure of the primary SRP module (hardware or software)
- Pushing the recessed reset button on the primary SRP module (see Figure 5-1)
- Issuing the **srp switch** command

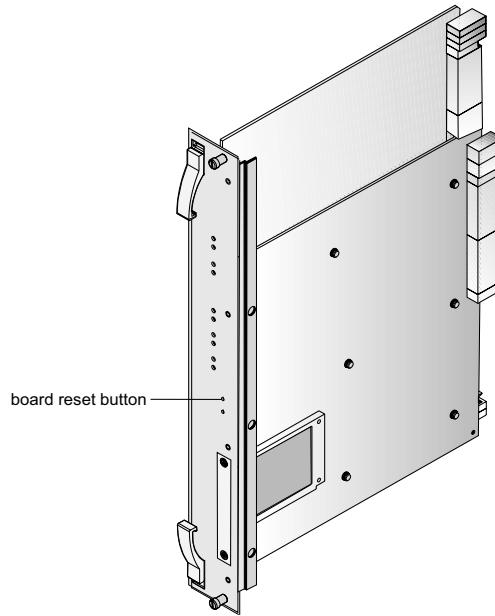

**Figure 5-1** SRP module

### *Installing a Redundant SRP Module*

You can install a redundant SRP module into a running system, provided that the redundant SRP module has a valid software release on its NVS card. Access to a software release in NVS ensures that the redundant SRP module can boot; the release need not be the same as that on the primary SRP module. To install a redundant SRP module into a running system, follow these steps:



**Warning:** Do not insert any metal object, such as a screwdriver, or place your hand into an open slot or the backplane when the system is on. Remove jewelry (including rings, necklaces, and watches) before working on equipment that is connected to power lines. These actions prevent electric shock and serious burns.



**Caution:** When handling modules, use an antistatic wrist strap connected to the systems's ESD grounding jack, and hold modules by their edges. Do not touch the components, pins, leads, or solder connections. These actions help to protect modules from damage by electrostatic discharge.

- 1 Install the redundant SRP module into the open SRP slot (slot 6 or 7 for the ERX-1400 series; slot 0 or 1 for the ERX-700 series).

For detailed information about installing the SRP module, see the *ERX Installation and User Guide*.

- 2 Wait for the redundant SRP module to boot, initialize, and reach the standby state.

When the module is in standby state, the REDUNDANT LED is on and the ONLINE LED is off. If you issue the **show version** command, the *state* field for the slot that contains the redundant SRP module should be *standby*.

- 3 Synchronize the NVS file system of the redundant SRP module to that of the primary SRP module.
- 4 Reboot the redundant SRP module.

### **reload slot**

- Use to reboot a selected slot on the router.
- Example

```
host1#reload slot 7
```
- There is no **no** version.

### **synchronize**

- Use to force the file system of the redundant SRP module to synchronize with the NVS file system of the primary SRP module.
- If you synchronize the redundant SRP module with the primary SRP module and the redundant module is armed with a release different than the one it is currently running, the redundant SRP module is automatically rebooted to load the armed release.
- Example

```
host1#synchronize
```
- There is no **no** version.

## *Managing SRP Module Redundancy*

You can prevent the redundant SRP module from taking over when:

- The primary SRP module experiences a software failure.
- You push the reset button on the primary SRP module.



**Note:** If you do not configure this option, when troubleshooting an SRP module, disconnect the other SRP module from the system. This action prevents the redundant SRP module from taking over if you push the reset button on the primary SRP module.

To configure this option:

- 1 Issue the **disable-switch-on-error** command.
- 2 Synchronize the NVS file system of the redundant SRP module to that of the primary SRP module.

Refer to the commands and guidelines in the previous section and below.

### ***disable-switch-on-error***

- Use to prevent the redundant SRP module from taking over if the primary SRP module experiences a software failure or if you push the reset button on the primary SRP module.
- Issue the **sync** command immediately before you issue this command.
- If you issue the **disable-switch-on-error** command, and later issue the **srp switch** command, the redundant SRP module waits about 30 seconds before it takes over from the primary SRP module.
- Example

```
host1(config)#disable-switch-on-error
```
- Use the **no** version to revert to the default situation, in which the redundant SRP module takes over if the primary SRP module experiences a software failure.

### ***synchronize***

- Use to force the NVS file system of the redundant SRP module to synchronize with the NVS file system of the primary SRP module.
- If you synchronize the redundant SRP module with the primary SRP module and the redundant module is armed with a release different than the one it is currently running, the redundant SRP module is automatically rebooted to load the armed release.
- Example

```
host1#synchronize
```
- There is no **no** version.

### *Switching to the Redundant SRP Module*

To switch immediately from the primary SRP module to the redundant SRP module, issue the **srp switch** command. You can configure the system to prompt you if the modules are in a state that could lead to loss of configuration data or NVS corruption.

### *srp switch*

- Use to switch from the primary SRP module to the redundant SRP module.
- If you specify the **force** keyword, the procedure will fail if the SRP modules are in certain states, such as during a synchronization. In these cases, the system will display a message that indicates that the procedure cannot currently be performed and the reason why. However, if the SRP modules are in other states that could lead to a loss of configuration data or an NVS corruption, the system displays a message that explains the state of the SRP modules, and asks you to confirm (enter yes or no) whether you want to proceed.
- If you do not specify the **force** keyword, the procedure will fail if the SRP modules are in any state that could lead to a loss of configuration data or an NVS corruption, and the system will display a message that explains why the command failed.
- When you issue this command, the system prompts you for a confirmation before the command takes effect.
- If you issue the **disable-switch-on-error** command, and later issue the **srp switch** command, the redundant SRP module waits about 30 seconds before it takes over from the primary SRP module.
- If the system does not contain a redundant SRP module, this command has no effect.
- Example
 

```
host1#srp switch
host1#srp switch force
```
- There is no **no** version.

### *Upgrading Software on a Redundant SRP Module*

For information about upgrading software on SRP modules, see *ERX Installation and User Guide, Appendix E, Installing ERX System Software*

### *Monitoring the Status LEDs*

You can determine the redundancy state of line modules and SRP modules by examining their status LEDs. See Table 5-4 for a description of the LEDs functions. In addition, if you issue the **show version** command, the *state* field for the slot that contains the redundant SRP module should be *standby*.

**Table 5-4** Function of the online and redundant LEDs

ONLINE LED	REDUNDANT LED	State of the Module
Off	Off	Module is booting or is an inactive primary line module.
On	Off	Module is active, but no redundant module is available.

**Table 5-4** Function of the online and redundant LEDs (continued)

ONLINE LED	REDUNDANT LED	State of the Module
Off	On	Module is in standby state.
On	On	Module is active, and a redundant module is available.

## Managing NVS Cards on SRP Modules

Each SRP module contains an NVS card that stores system files. In this documentation, the NVS card on the primary SRP module is referred to as the primary NVS card; the NVS card on the redundant SRP module is referred to as the redundant NVS card.

If you have two SRP modules installed in a system, you can use NVS cards of different capacities on the SRP modules. The effective capacity of the higher-capacity NVS card will equal that of the lower-capacity NVS card.

### *NVS Features*

The software contains a number of features that optimize the way the system restores its configuration if it is shut down improperly:

- The system tracks improper shutdowns.
- If you shut down the system improperly, it will run an investigation of the file allocation table (FAT) the next time it reboots.
- The system creates backups of critical files.
- When you install a new NVS card or restart the system after shutting it down incorrectly, a utility scans the NVS card to detect corrupt sectors. If the utility finds files or directories that contain corrupt sectors, it removes the files and directories, because they can no longer be used. The utility also fixes problems with unused sectors. If the utility cannot correct a corrupt sector, it marks the sectors so that they cannot be reused.
- In a system that contains two SRP modules, if the scanning utility detects corrupt sectors in NVS on the primary SRP module during rebooting, the primary SRP module will reboot again. Both SRP modules will now have standby status and will be rebooting. The first SRP module to complete rebooting will assume the primary role. Because the former redundant module started to reboot first, it will probably assume the primary role. When the former primary has

rebooted and the scan utility has fixed corrupt sectors in its NVS, the SRP modules will synchronize. Any files or directories removed by the scan utility will be restored during the synchronization.

- If you reboot the system before it has completely written configuration updates to NVS, the system will start with the last saved configuration. If you reboot the system after it has written the configuration updates to NVS, but before it has applied those updates to actual configuration data, the configuration update process resumes immediately following the reboot and completes before any application accesses its configuration data.

To prevent corruption of NVS cards, always issue the **halt** command before you remove an NVS card or an SRP module (see *Removing an SRP Module*). Always reboot the system using the rebooting procedure (see *Chapter 8, Booting the System*); do not reboot the system by switching it off and on.

### *Installing and Removing NVS Cards*

For information about replacing NVS cards, see *ERX Installation and User Guide, Chapter 3, Installing ERX Modules*.

### *Synchronizing NVS Cards*

If the system contains two SRP modules, it is important to keep the contents of the modules' NVS cards synchronized. Synchronization prevents the redundant NVS card from overwriting saved files on the primary NVS card if the primary SRP module fails and the redundant SRP module assumes control.

By default, autosynchronization is enabled on the system. Autosynchronization runs as a background process every 5 minutes, tracking changes in image, configuration, and script files, and keeping the two SRP modules synchronized. You can also synchronize the SRP modules manually by issuing the **synchronization** command.

Before synchronization, the system does the following:

- Checks that critical files on the primary SRP module are present. If there are missing files, the system does not proceed with the synchronization.
- Checks whether there is enough space on the redundant NVS to copy all the new or changed files from the primary NVS card.

Depending on the outcome of the second check, the system proceeds as follows:

- If there is enough space, the system copies new or changed files from the primary NVS card to the redundant NVS card without deleting any files on the redundant NVS card. If the system is interrupted when it is synchronizing with this method, the synchronization will resume when it has recovered from the interruption.
- If there is not enough space, the system deletes any files on the redundant NVS card that do not appear on the primary NVS card, then copies new or changed files from the primary NVS card to the redundant NVS card. If the system is interrupted when it is synchronizing with this method, it will not resume with the synchronization when it has recovered from the interruption.

If an SRP synchronization is in progress or has failed and the system is recovering, the system will prevent the redundant SRP module from assuming the primary role while the primary is rebooting, and for thirty seconds after the primary has rebooted. These conditions prevent a redundant SRP module with corrupted or missing files from becoming the primary and overwriting files or directories on the primary module.

### ***synchronize***

- Use to force the file system of the redundant SRP module to synchronize with the NVS file system of the primary SRP module.
- If you synchronize the redundant SRP module with the primary SRP module and the redundant module is armed with a release different than the one it is currently running, the redundant SRP module is automatically rebooted to load the armed release.
- Example  

```
host1#synchronize
```
- There is no **no** version.

### Synchronizing NVS Cards of Different Capacities

If the capacity of the primary NVS card is equal to or smaller than that of the redundant NVS card, the system copies all the files from the primary NVS card to the redundant NVS card. However, if the capacity of the primary NVS card exceeds that of the redundant NVS card, the system creates an invisible synchronization reserve file on the primary NVS card, provided that there is enough space for the file.

The purpose of the synchronization file is to prevent the creation of data that will not fit on the redundant NVS card. The file contains no useful data, and is not visible when you view the files in NVS. The size of the file is equal to the difference in capacities of the two NVS cards. For example, if the primary NVS card has a capacity of 224 MB, and the redundant NVS card has a capacity of 220 MB, the size of the synchronization file is 4 MB, and only 220 MB of space is available on the primary NVS card.

If there is not enough space on the primary NVS card to create the synchronization reserve file, the **synchronize** command fails, and you see a warning message on the console. To resolve this issue, either delete unwanted files from the primary NVS card or replace the redundant NVS card with a higher-capacity NVS card.

#### Disabling Autosynchronization

If autosync is enabled while you are copying very long scripts or installing new software releases, it detects a disparity between the modules during the middle of the process. This feature causes significant unnecessary synchronization, resulting in prolonged copy times.

If you have installed a redundant SRP module, perform the following steps before copying long scripts:

- 1 Turn off autosynchronization with the **disable-autosync** command.
- 2 Perform the installation or copy the script.
- 3 Reenable autosynchronization with the **no disable-autosync** command.
- 4 Manually synchronize the modules with the **synchronize** command.

Refer to the commands and guidelines in the previous section and below.

#### ***disable-autosync***

- Use to turn off automatic synchronization between the primary and redundant SRP modules.
- Example

```
host1(config)#disable-autosync
```
- Use the **no** version to revert to the default situation, in which automatic synchronization runs as a background process every 5 minutes.

### Reformatting the Primary NVS Card

You can reformat the primary NVS card. To do so:

- 1 Access Boot mode.
  - a From Privileged Exec mode, enter the **reload** command. Information on the reloading process displays.
  - b When the countdown begins, press the <mb> key sequence (case-insensitive).

This puts the CLI in Boot mode (:boot## prompt).  
If you do not press the <mb> key sequence, the reloading process continues and returns the CLI to the normal User Exec mode.

- 2 Issue the **flash-disk initialize** command.

#### **flash-disk initialize**



- Use to reformat the NVS card.
- You can perform a low-level format of the NVS card.
- **Note:** This command is available only in the Boot mode.
- Example

```
host1#halt primary
host1#reload
WARNING: Execution of this command will cause the system to
reboot.
Proceed with reload? [confirm]
Reload operation commencing, please wait...
[ Press mb]
:boot##flash-disk initialize
```

- There is no **no** version.

### Copying the Image on the Primary SRP Module

You can copy the contents of NVS on the primary SRP module to a spare NVS card. To do so:

- 1 Access Boot mode.
  - a From Privileged Exec mode, enter the **reload** command. Information on the reloading process displays.
  - b When the countdown begins, press the <mb> key sequence (case-insensitive).

This action puts the CLI in Boot mode (:boot## prompt).  
If you do not press the <mb> key sequence, the reloading

process continues and returns the CLI to the normal User Exec mode.

- 2 Issue the **flash-disk duplicate** command.
- 3 Follow the instructions on the screen. When prompted, insert the original or spare NVS card in the primary SRP module.

### **flash-disk duplicate**

- Use to copy the contents of the primary NVS card to a spare NVS card.
- The primary and spare NVS cards must be from the same manufacturer and must have the same size.



**Note:** This command is available only in the Boot mode.

- When you issue the **flash-disk duplicate** command, insert the original and spare NVS cards when prompted. The system copies the NVS contents incrementally, so you may need to exchange the NVS cards several times.

- Example

```
host1#halt primary
host1#reload
WARNING: Execution of this command will cause the system to
reboot.
Proceed with reload? [confirm]
Reload operation commencing, please wait...
[ Press mb]
:boot##flash-disk duplicate
```

- There is no **no** version.

### Scanning NVS Cards

You can scan NVS to find files with errors. You can also run a scan that will remove files with errors and attempt to repair corrupted areas in NVS. If the repair fails, the system will no longer use the corrupted areas.

### **flash-disk scan**



- Use to scan and repair files on the NVS cards.

**Note:** This command is available only in the Boot mode.

- If the system contains primary and redundant modules, NVS on the primary SRP module will be scanned.

- Example

In this example, the user scans NVS and finds one file with an error. The user then issues the **flash-disk scan** with the **repair** keyword to remove the file. Finally, the user scans NVS again, and finds no files with errors.

```
:boot##flash-disk scan
Proceed with Flash disk scan? [confirm]
Srp PCMCIA Card Scan...
```

```
Boot Block OK
File Allocation Table OK
Root Directory OK
Checking File Space
Please Wait...
Checking Free Space
Please Wait...
PCMCIA Card Scan Detected Errors in:
\\images\ctlDiag\ctlDiag3c440e9e.cmp
```

PCMCIA Card Scan successful!

```
:boot##flash-disk scan repair
WARNING: Execution of this command may cause the contents of
the Flash disk to
    be modified.
Proceed with Flash disk scan? [confirm]
Srp PCMCIA Card Scan...
Boot Block OK
File Allocation Table OK
Root Directory OK
Checking File Space
Please Wait...
Checking Free Space
Please Wait...
PCMCIA Card Scan Removed:
\\images\ctlDiag\ctlDiag3c440e9e.cmp
```

PCMCIA Card Scan successful!

```
:boot##flash-disk scan
Proceed with Flash disk scan? [confirm]
Srp PCMCIA Card Scan...
Boot Block OK
File Allocation Table OK
Root Directory OK
Checking File Space
Please Wait...
Checking Free Space
Please Wait...
PCMCIA Card Scan successful!
```

- There is no **no** version.

## Monitoring NVS Cards

Use the **show nvs** command to monitor information about NVS on the primary SRP module.

### **show nvs**

- Use to monitor NVS status.
  - Field descriptions
    - › total nvs file sizes – sum of sizes of all files in NVS, in bytes
    - › total nvs file errors – number of read and write errors in all files in NVS
    - › nvs flash in use – NVS used, in bytes
    - › available nvs flash – NVS available, in bytes
- ```
total nvs file sizes = 228864
total nvs file errors = 0
nvs flash in use = 1265152
available nvs flash = 35435008
```

## Managing the Ethernet Port on the SRP Module

---

For information about configuring the Fast Ethernet port on the SRP I/O module, see *ERX Installation and User Guide, Chapter 5*, .

Use the Fast Ethernet port on the SRP I/O module only as a system management port. Do not use this port to route Fast Ethernet traffic, because doing so affects the performance of the system.

Use an FE-2 line module and an FE-2 I/O module or a GE/FE line module and an FE-8 I/O module to route 10/100BaseT traffic. For information about configuring Ethernet interfaces, see *Chapter 6, Configuring Ethernet Interfaces*.

### **interface fastEthernet**

- Use to select an FE interface on a line module or SRP module.
- Example

```
host1-0-1-90(config)#interface fastEthernet 1/0
```
- Use the **no** version to remove IP from an interface or subinterface.

## Monitoring Statistics

You can set a baseline and view statistics on the Fast Ethernet port of the SRP I/O module in the same way that you would for other Ethernet interfaces. See *Chapter 6, Configuring Ethernet Interfaces*.

*Monitoring the Ethernet Configuration for the SRP Module*

Slots 0 and 1 are reserved for SRP modules on the ERX-700 series; slots 6 and 7 are reserved for SRP modules on the ERX-1400 series. When you configure the Fast Ethernet interface on an SRP module, the output of the **show config** command always indicates that the interface is configured in the lower of the two slots (slot 0 or slot 6). This is true if you configure the interface on a redundant SRP module in the higher slot or even if you have only one SRP module and it is installed in the higher slot, as shown in the following example:

```

host1#show version
Juniper Networks Edge Switch Router ERX1400
Copyright (c) 1998-2001 Juniper Networks, Inc. All rights reserved.
System Release: x-y-z.rel
      Version: x-y-z (April 25, 200X 09:44)
System running for: 0 days, 0 hours, 4 minutes, 43 seconds
      (since TUE MAY 01 2001 20:27:19 UTC)

slot      state      type      admin      spare      running
-----  -
0         ---       ---       ---       ---       ---
1         ---       ---       ---       ---       ---
2         online    UT3a      enabled    ---       x-y-z.rel
3         online    OC3dP2    enabled    ---       x-y-z.rel
4         ---       ---       ---       ---       ---
5         ---       ---       ---       ---       ---
6         ---       ---       ---       ---       ---
7         online    SRP-10G   enabled    ---       x-y-z.rel
8         standby   OC3/OC12-ATM  enabled    spare     x-y-z.rel
9         ---       ---       ---       ---       ---
10        online    OC3-4A     enabled    ---       x-y-z.rel
11        online    OC3-4A     enabled    ---       x-y-z.rel
12        online    OC3-4A     enabled    ---       x-y-z.rel
13        ---       ---       ---       ---       ---

host1#configure terminal
Enter configuration commands, one per line. End with CNTL/Z.
host1(config)#interface fastethernet 7/0
host1(config-if)#ip address 10.6.130.83 255.255.128.0
host1(config-if)#exit
host1(config)#ip route 0.0.0.0 0.0.0.0 10.6.128.1
host1(config)#exit
host1#show config
! Juniper Networks Edge Switch Router RX1400
! Version: x-y-z (April 25, 2001 09:44)
! Copyright (c) 1998-2001 Juniper Networks, Inc. All rights reserved.

```

```
!  
! Configuration script generated on TUE MAY 01 2001 20:33:20 UTC  
boot config running-configuration  
boot system x-y-z.rel  
no boot backup  
no boot subsystem  
no boot backup subsystem  
no boot force-backup  
no boot slot  
!  
hostname "host1"  
exception protocol ftp anonymous null  
!  
controller t3 2/0  
[...]  
!  
interface fastEthernet 6/0  
 ip address 10.6.130.83 255.255.128.0  
!  
ip route 0.0.0.0 0.0.0.0 10.6.128.1  
! Trap Source: <not configured>  
! Note: SNMP server not running.  
!
```

## Monitoring Modules

---

Use the following commands to view information about line modules and SRP modules.

### ***show hardware***

- Use to display information about the SRP modules, line modules, and I/O modules in the system.
- Field descriptions
  - › slot – physical slot that contains the module
  - › type – kind of module; an “e” at the end of an SRP module type (for example, SRP-5Ge) indicates that the module includes error-checking code (ECC).
  - › serial number – serial number of the module
  - › assembly number – part number of the module
  - › assembly rev. – hardware revision of the module
  - › ram (MB) – memory capacity of the host processor
  - › number of MAC addresses – total number of Ethernet addresses on an I/O module
  - › base MAC address – lowest Ethernet address on an I/O module

- Example

host1#**show hardware**

| slot | type   | serial number | assembly number | assembly rev. | ram (MB) |
|------|--------|---------------|-----------------|---------------|----------|
| 0    | SRP-5G | 7199160022    | 3400002900      | A03           | 128      |
| 1    | ---    | ---           | ---             | ---           | ---      |
| 2    | ---    | ---           | ---             | ---           | ---      |
| 3    | OC3dP2 | 7199190218    | 3401002800      | A02           | 64       |
| 4    | ---    | ---           | ---             | ---           | ---      |
| 5    | CT3P2  | 7199160121    | 3401002501      | A02           | 64       |
| 6    | CT2    | 7199160311    | 3401002011      | A03           | 64       |

| slot | type       | serial number | assembly number | assembly rev. | number of MAC addresses |
|------|------------|---------------|-----------------|---------------|-------------------------|
| 0    | SRP-5G I/O | 7199170147    | 3400003301      | A01           | 16                      |
| 1    | ---        | ---           | ---             | ---           | ---                     |
| 2    | ---        | ---           | ---             | ---           | ---                     |
| 3    | OC3dP2 I/O | 7199030030    | 3400003400      | A01           |                         |
| 4    | ---        | ---           | ---             | ---           | ---                     |
| 5    | CT3P2 I/O  | 7199150162    | 3400003200      | A03           |                         |
| 6    | CT1 I/O    | 7199460217    | 3400006401      | A02           |                         |

| slot | base MAC address  |
|------|-------------------|
| 0    | 00-90-1a-00-09-a0 |
| 1    | ---               |
| 2    | ---               |
| 3    |                   |
| 4    | ---               |
| 5    |                   |
| 6    |                   |

**show utilization**

- Use to display information about the resources that modules consume.
- Field descriptions
  - › slot – slot in which the line module resides
  - › type – type of module
  - › heap % – percentage of the RAM that is currently in use by software running on the line module
  - › cpu % – percentage of line module's CPU capacity currently used

- › bw exceed – status of bandwidth oversubscription for this slot (this field appears only when bandwidth oversubscription is configured)
  - Y indicates that this slot is in an oversubscribed slot group
  - --- indicates no line module installed or no bandwidth oversubscription

host1#show utilization

```
System Resource Utilization
-----
slot      type          heap    cpu    bw
          (%)         (%)    exceed
-----
0         DPFE          65     35     Y
1         OC12Atm(P2)  59     44     Y
2         OC3/OC12-ATM 67     53     Y
3         ---          ---     ---    ---
4         ---          ---     ---    ---
5         OC3d         79     0      ---
6         SRP-10G     27     1      ---
7         ---          ---     ---    ---
8         ---          ---     ---    ---
9         ---          ---     ---    ---
10        CE1         45     25     ---
11        ---          ---     ---    ---
12        UT3a       77     0      ---
13        ---          ---     ---    ---
```

