

Applications Overview

6

This chapter details several applications that the ERX system supports and describes the feature sets that make these applications successful.

Topic	Page
Private Line Aggregation	6-2
xDSL Session Termination	6-4
Ethernet Access	6-7
Virtual Private Networks	6-10
Cable Subscriber Management	6-12
MPLS for Traffic Control	6-16
MPLS for VPNs	6-18
SLA Support	6-19
Non-IP Protocol Applications	6-20
VoIP Transport	6-20
Wholesaling	6-22
End-to-End QoS	6-24
VLAN Implementation	6-26
Fixed Wireless Applications	6-27
SMDS Application	6-28

Private Line Aggregation

A main application for the ERX edge router is private line aggregation, the consolidation of multiple high-speed access lines into one access point. Figure 6-1 shows the application.

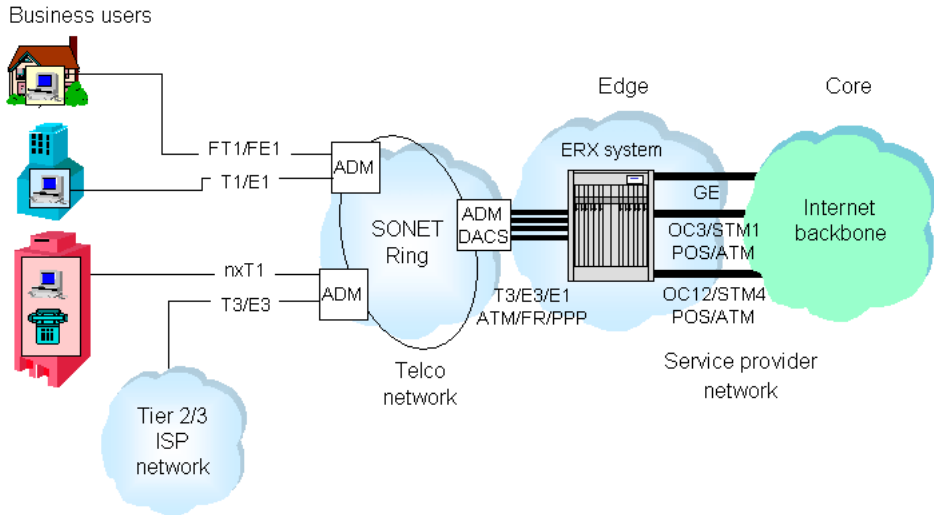

Figure 6-1 Private line aggregation application

In this application, the service provider can use a single ERX system to offer high-speed access (FT1/FE1 through T3/E3) to thousands of subscribers with a single unit. The Telco provider can multiplex individual subscriber lines into T3 lines and feed them into the ERX system. (The system also accepts unchannelized T3 or E3 connections from high-speed users and channelized E1 connections directly into the unit.) The system handles all IP packet processing, including the assignment of QoS and routing policies. It then routes packets into the backbone network.

The system supports a number of access and uplink methods; Table 6-1 lists the most common pairings.

Table 6-1 Common access/uplink pairings

Access	Uplink
PPP	
Frame Relay	ATM or POS
ATM	

Remember, however, that any port on the ERX system can be used for access or uplink. This means that both PPP and Frame Relay ports can be used as uplink ports as well. This configuration can accommodate subscribers who have two sites connected to the same ERX system over Frame Relay or PPP links, or can provide an uplink for a Frame Relay service.

Subscriber Links and Protocols Supported

For private line aggregation, the subscriber links can be:

- Fractional T1/E1
- T1/E1
- *nx*T1 or *nx*E1
- T3/E3, *nx*T3, or *nx*E3
- OC3/STM1 or *nx*OC3/STM1
- VLANs/Ethernet (10/100 Base-T or 1000 Base-LX/SX)

The protocols supported include IP/PPP, IP/Frame Relay, IP/HDLC, and IP/ATM from the subscriber premises. The local Telco network may multiplex the links into a channelized copper or optical line to be terminated by the ERX system. The system can also receive direct E1, E3, FE, GE, OC/STM1, OC12/STM4T1, or T3 connections for termination.

Features and Benefits

By using the ERX system for private line aggregation, a service provider can overcome a number of limitations found in older products, such as density constraints, performance limitations, and lack of carrier-class reliability. In addition, the service provider gains the ability to offer a number of new IP services to its subscriber base.

The ERX system offers a number of key features that deliver critical benefits to service providers who offer private line aggregation. Table 6-2 lists these features.

Table 6-2 ERX features and benefits for private line aggregation

ERX Features	Service Provider Benefits
10x density improvement over older products with support for 4,000 FT1s and 1,000 T1s per chassis	Alleviates space constraints in central offices and POPs and allows service providers to deliver more high-speed connections in a smaller footprint, with lower power draw

Table 6-2 ERX features and benefits for private line aggregation (continued)

ERX Features	Service Provider Benefits
Wire-speed packet processing on all interfaces with ERX ASIC technology	Delivers high-performance throughput to subscribers and supports delivery of QoS policies
Carrier-class reliability with NEBS-compliant hardware design, hot-swappable modules, and redundancy, and modular software architecture	Allows service providers to offer SLAs with assurance of maximum uptime
Sophisticated frame-processing capabilities distributed down to each line module	Supports deployment of new IP services such as QoS, detailed accounting, and VPNs, while maintaining wire-speed routing
Fine-grained, wire-speed IP QoS capabilities for up to 64,000 subscriber flows	Allows innovative IP services to be created for the entire subscriber base, including: <ul style="list-style-type: none"> • Throughput guarantees (maximum and minimum) • Preferred traffic treatment (Gold, Silver, Bronze) • Customer-specific traffic treatment • Application-specific traffic treatment
Detailed statistics gathering for each subscriber and for each service	Provides information required for bill generation and SLA reports
Highly scalable and robust routing protocols: BGP-4, IS-IS, OSPF, and RIP	<ul style="list-style-type: none"> • Allows service providers to run a combination of routing protocols across the network • Allows service providers to scale to support thousands of router peers and route tables with hundreds of thousands of entries to keep pace with network growth

xDSL Session Termination

The ERX system lets service providers offer xDSL services by following a cost-effective dial remote access server (RAS) model. The system keeps all dial-up OSS protocols and systems in place and uses them to implement oversubscription policies for precious bandwidth and IP resources.

As shown in the application in Figure 6-2, the ERX system handles the aggregated output from the DSLAMs. The DSLAMs are directly connected to the subscriber premises, handle the copper termination, and aggregate the traffic into a higher-speed uplink. The output from the DSLAM is fed into the system via a DS3 or OC3 link.

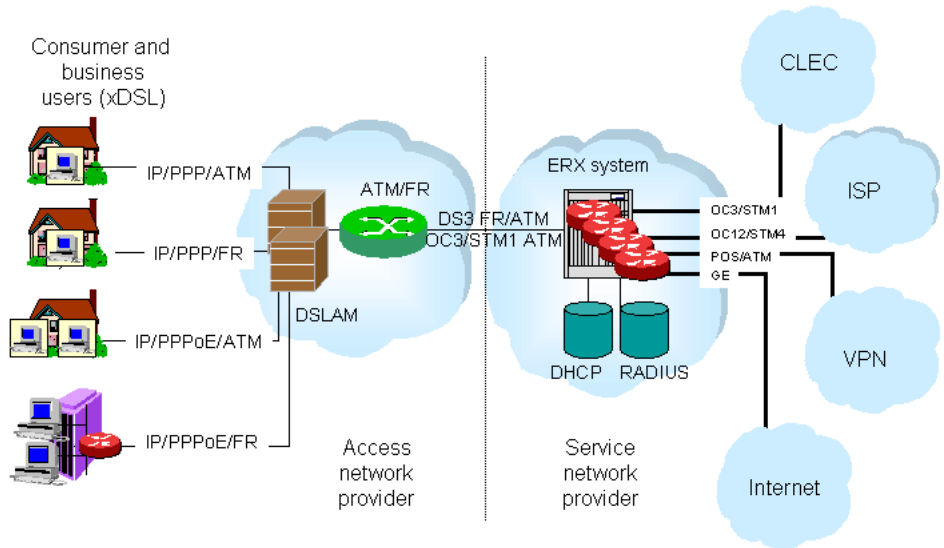

Figure 6-2 xDSL aggregation with the ERX system

The ERX system then handles several functions:

- PPP session termination and authentication checking via PAP or CHAP
- Coordination with DHCP servers and local IP pools to assign IP address
- Connection to RADIUS servers or use of domain names to associate subscriber with user profile information
- Support for RADIUS accounting to gather detailed billing information
- Application of the user profile to the user traffic flow, which could include QoS, VPN, and routing profiles

The output of the ERX system is typically a high-speed link, such as OC3/STM1 or OC12/STM4, to feed a core backbone router. Virtual routers can also be used to keep the traffic logically separate and direct packets to different destinations. As shown in Figure 6-2, packets can be directed to a CLEC, ISP, corporate VPN, or the Internet.

xDSL Protocol Support

The system supports a large number of xDSL protocols, including:

- IP/PPP/ATM
- IP/PPP/Ethernet/ATM
- IP/PPP/Frame Relay
- IP/PPP/Ethernet/Frame Relay

This protocol support allows service providers to install a central site router that can terminate signals from a wide variety of CPE xDSL devices.

DSLAM Support

The system supports any type of DSLAM, including those that terminate any of the following DSL types.

- Asymmetric digital subscriber line (ADSL)
- Rate-adaptive digital subscriber line (RADSL)
- Symmetric digital subscriber line (SDSL)
- ISDN digital subscriber line (IDSL)
- Very-high-bit-rate digital subscriber line (VDSL)

The DSLAM terminates the copper, and the ERX system provides the logical termination for the IP session, as well as the interface to authentication and accounting systems with PAP, CHAP, and RADIUS.

Features and Benefits

By using the ERX system for B-RAS, the service provider can overcome a number of limitations found in older products, as well as offer a number of new services to the subscriber base. Table 6-3 lists the many features that the ERX system offers to support B-RAS.

Table 6-3 ERX features and service provider benefits for B-RAS

ERX Features	Service Provider Benefits
100x density improvement over older products with support for 32,000 IP interfaces in a single chassis	Provides service providers with a cost-effective platform from which to roll out high-consumption but low-cost xDSL services.
Wire-speed packet processing on all interfaces with ERX system ASIC technology	Delivers high-performance throughput to subscribers and supports delivery of QoS policies

Table 6-3 ERX features and service provider benefits for B-RAS (continued)

ERX Features	Service Provider Benefits
Carrier-class reliability with NEBS-compliant hardware design, hot-swappable modules, and redundancy, and modular software architecture	Allows service providers to offer SLAs with assurance of maximum uptime
Fine-grained, wire-speed IP QoS capabilities for up to 64,000 subscriber flows	Allows innovative IP services to be created for the entire subscriber base, including: <ul style="list-style-type: none"> • Throughput guarantees (maximum and minimum) • Preferred traffic treatment (Gold, Silver, Bronze) • Customer-specific traffic treatment • Application-specific traffic treatment
Detailed statistics gathering for each subscriber and for each service, and support for RADIUS accounting	Provides information required for bill generation and SLA reports, and integrates with current OSSs
Highly scalable and robust routing protocols developed to meet large-scale service provider needs: BGP-4, IS-IS, OSPF, and RIP	With ERX support for BGP-4 and IS-IS, service providers can offer xDSL services from a network-peer platform, rendering two-stage B-RAS solutions obsolete
Ability to support logically separate virtual routers within a single chassis	Allows service providers to securely route traffic targeted at different destinations (such as corporate VPN vs ISP)
Support for PPP, CHAP, PAP, DHCP, and RADIUS	Allows service providers to roll out xDSL services using existing dial OSS infrastructure, greatly reducing the cost of offering a new price-competitive service

Ethernet Access

Ethernet is on the move. It has conquered the LAN and is now pursuing the MAN. There are a number of emerging applications for the use of Ethernet in the MAN, including:

- **Consumer Ethernet** – A consumer service where Ethernet, rather than xDSL, is used as an access method. This model looks like xDSL, with the ERX system requiring B-RAS, RADIUS, and PPP services.
- **Business Ethernet** – A high-speed Internet access offering for business users. In this model, VLAN technology provides circuit aggregation (comparable to a T1), with the GE as the channelized interface (similar to a cOCx). One GE carries many VLANs. In this model, the ERX system is used in its circuit aggregation role to terminate the VLANs and route traffic into the network.

Industry experts expect a successful implementation of Ethernet in the access layer for two major reasons: it is fast and cheap. The following catalysts for the adaptation of Ethernet are compelling and unlikely to change, making this a viable access technology option:

- Price points are significantly lower than traditional WAN ports, due to the drive in the consumer market.
- Customers already use Ethernet, so protocol conversion is unnecessary (saving expense).
- Bandwidth is becoming more plentiful (and therefore cheaper) in metropolitan areas, so no statistical gains from an access layer are required.
- Standards bodies are developing Ethernet-based ring technologies to challenge SONET/SDH as the access transport layer, making an all-Ethernet-transport from CPE to POP.

The next sections show where the ERX system can be used in these new emerging Ethernet markets.

Consumer Ethernet

As shown in Figure 6-3, the ERX system handles all the subscriber management functions typically found in the xDSL network:

- Assignment of VLAN tags used to identify subscribers
- All AAA functions, including accounting
- Backhauling of traffic to ISPs, using VRs or L2TP
- Both PPPoE/VLAN and clientless access (using the integrated DHCP server)

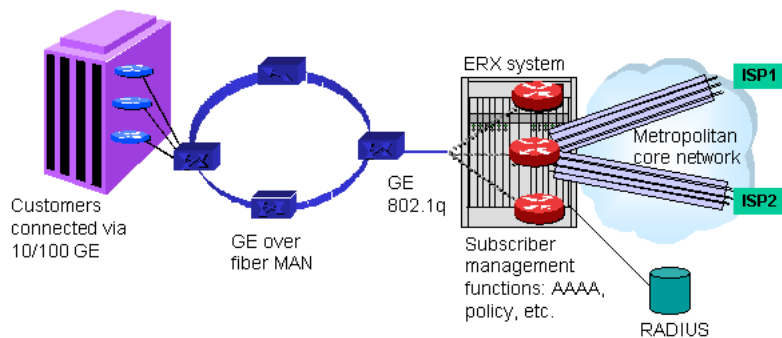

Figure 6-3 ERX system in a consumer Ethernet application

Business Ethernet

As shown in Figure 6-4, the ERX system is the on-ramp for metropolitan traffic into the rest of the network. This type of network replaces traditional T1/E1 access with Ethernet access. In this model, as in the previous one, the layer 2 Ethernet switches are located at the CPE and assign VLAN tags to the subscriber site (in this case, the office LAN). The ERX system connects the business site to the “real” world.

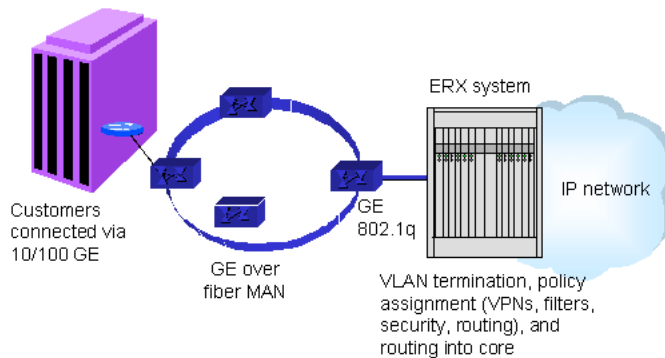

Figure 6-4 ERX system in a business Ethernet application

Implications for the ERX system

The ongoing market shift toward Ethernet as an access layer has the following implications for the ERX system:

- **Consumer Ethernet** – The ERX system fits as a B-RAS for FTTS (fiber to the subscriber) and can support both PPP and non-PPP models. Customers for this product are existing suppliers of residential broadband service (ILECs, PTTs, CLECs).
- **Business Ethernet** – The ERX system can be used as a circuit aggregation router for Ethernet. All of the edge circuit aggregation functions that the ERX system supports add value here: IP interface count, policies, statistics, MPLS, routing protocols, etc. The ERX-1440 has sufficient bandwidth for this application.
- **Metropolitan Ethernet for Business** – The ERX-1440 qualifies as the off-ramp to the real world (for example, IP backbone) in the same manner as explained in the business Ethernet application.

Other features of the ERX system that are relevant in this Ethernet market segment include: wire-rate performance, routing protocols, and B-RAS support. Also, Ethernet-specific features include support for:

- VLANs (802.1q) on the FE-2, FE-8, and GE line modules. The full count of 4,096 tags is supported per physical port. The FE-8 and the

GE also support 8,000 IP interfaces per line module, and the VLANs can be distributed over these ports.

- VRRP provides redundancy on a LAN segment.
- VMAN provides the ability to stack VLAN tags in order to extend the number of users supported by a single LAN segment.
- Standard 802.3ad enables multiple Ethernet segments to transport a single traffic stream (similar to multilink).

Virtual Private Networks

VPNs are secure, logically partitioned, private IP networks provisioned over a common shared IP infrastructure. The ERX system allows service providers to offer VPNs to telecommuters, branch business sites, and wholesale partners.

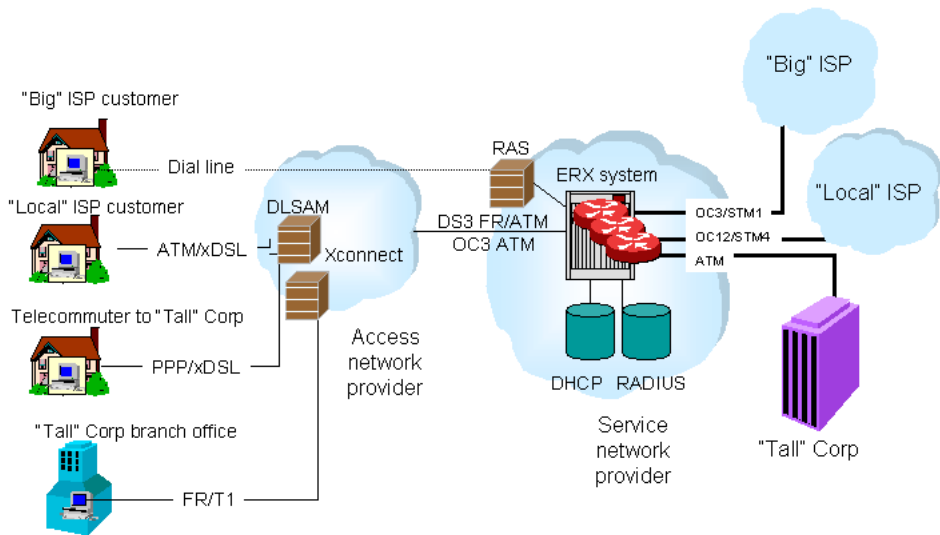

Figure 6-5 Delivery of VPNs over a shared IP infrastructure

As shown in Figure 6-5, many subscribers are coming into the service provider network via a variety of access methods and with a variety of destinations. The ERX system is capable of handling all of the protocols and line rates. For xDSL users, a DSLAM would first terminate the copper before passing the traffic into the ERX system. For the dial-up user, a RAS would first answer the modem call before handing the data flow to the ERX system.

Subscribers entering the network via dedicated leased lines would typically be multiplexed into T3 lines and then enter the ERX unit (or be directly connected to the ERX system in the cases of T3, E3, and E1).

Once the packet enters the ERX system, any combination of classification filters can be used to identify the subscriber and the destination, or, for PPP users, a query can be made to a deployed RADIUS server.

There are three ways in which the ERX system can initiate the VPN to securely send traffic to different destinations:

- The ERX system supports layer 2 virtual circuits for either Frame Relay or ATM. Each incoming subscriber traffic flow can be mapped to a secure Frame Relay/ATM VC for transport to the destination address.
- The ERX system can support multiple virtual routers with separate, secure routing tables and IP forwarding processes. These virtual routers maintain separate routing tables for each router instance. This keeps traffic completely segmented between subscriber groups with different destinations.
- The ERX system can append MPLS labels to forward packets over directed VPN paths that the service provider configures.

The ERX system supports a number of key features that benefit a service provider who offers the VPN services detailed in Table 6-4.

Table 6-4 ERX features and service provider benefits for VPNs

ERX Features	Service Provider Benefits
Support for a wide variety of access protocols: Frame Relay, PPP, ATM, and POS	Gives service providers a single unit that can deliver a wide range of services to subscribers, including both legacy and new IP services
Wire-speed packet processing on all interfaces with ERX ASIC technology	Delivers high-performance throughput to subscribers and supports delivery of QoS policies
Carrier-class reliability with NEBS-compliant hardware design, hot-swappable modules, and redundancy, and modular software architecture	Allows service providers to offer SLAs with assurance of maximum uptime

Table 6-4 ERX features and service provider benefits for VPNs (continued)

ERX Features	Service Provider Benefits
Fine-grained, wire-speed IP QoS capabilities for up to 64,000 subscriber flows	Allows innovative IP services to be created for the entire subscriber base, including: <ul style="list-style-type: none"> • Throughput guarantees (maximum and minimum) • Preferred traffic treatment (Gold, Silver, Bronze) • Customer-specific traffic treatment • Application-specific traffic treatment
Detailed statistics gathering for each subscriber and for each service	Provides information required for bill generation and SLA reports
Ability to support logically separate virtual routers within a single chassis	Allows service providers to securely route traffic targeted at different destinations (such as corporate VPN vs ISP)

Cable Subscriber Management

As shown in Figure 6-6, an ERX system can aggregate traffic from cable modem termination systems (CMTSs) for access to the Internet backbone when deployed by multiservice operators (MSOs) in regional or “super” headend locations. The ERX system simultaneously aggregates data traffic from existing and future cable networks by supporting both data-over-cable service interface specifications (DOCSIS) and non-DOCSIS networks.

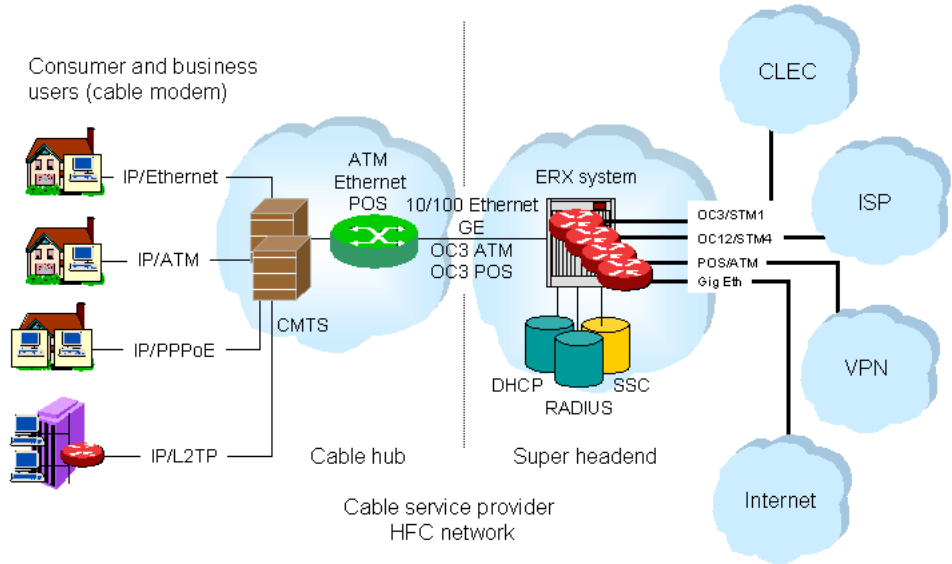

Figure 6-6 Cable subscriber management application

The CMTS is located at local hubs to terminate radio frequency signals from cable modems at residential and business locations. The CMTS bridges (or routes) traffic to the system at the headend for IP session termination. The links from the CMTS to the ERX system can be:

- ATM
- Ethernet
- Gigabit Ethernet
- Packet over SONET

ERX System Support

The ERX system supports a variety of encapsulation technologies to interoperate with existing cable networks and support future equal access initiatives. The ERX system supports the following cable protocols:

- ATM 1483
- ATM 1577
- PPPoE
- L2TP

The aggregation of the CMTS traffic to the ERX system is typically across a high-speed link, such as Gigabit Ethernet or OC3/STM1. The

output of the ERX system is typically a high-speed link, such as OC3/STM1 or OC12/STM4, to feed a core backbone router. Virtual routers can also be used to keep traffic logically separate and create separate management domains to support an equal access ISP model.

The ERX system handles the following functions:

- Support for both PPP-based as well as IP-based session termination and authentication
- Coordination with DHCP servers and local IP pools to assign IP address
- Connection to RADIUS services or use of domain names to associate subscriber with user profile information
- Support for RADIUS and IP accounting to gather detailed billing information
- Application of the user profile to the user traffic flow, which could include QoS, VPN, and routing profiles

Features and Benefits

The scalability and wire-speed performance of the ERX system allows cable operators to leverage lower-cost, layer 2 CMTS products and preserve legacy investments. Integrated layer 3-enabled CMTS solutions require MSOs to displace current layer 2 CMTS products with more expensive equipment. Located at the regional or “super” headend sites, the ERX system supports multiple existing service areas from a single platform to offer advanced IP services while minimizing cost. In addition, this model centralizes more complex network tasks to improve the operational efficiency of the MSO when new networks and new services are introduced.

The ERX system allows cable operators to offer differentiated services to their subscribers to increase revenues. The systems’ unique IP QoS capabilities support tiered services to deliver multiple service offerings to meet a variety of consumer application and economic requirements. In addition to core static services, the system supports on-demand services and dynamic QoS to offer pay-per-use data services, which are analogous to pay-per-view cable TV services. While increasing revenue, these services also help to improve customer retention and hold off competitive pressures from xDSL and wireless services.

Advanced QoS services of the ERX system will differentiate latency-sensitive VoIP traffic from best-effort data to deliver toll-quality telephony over a packet infrastructure. MSOs competing as CLECs that use the ERX system are positioned to offer a complete Packet Cable solution.

Because the ERX system is access agnostic, the same system can be used to deliver a consistent subscriber management and advanced IP services platform. This platform supports a complete broadband solution integrating xDSL, cable, and wireless into a single network.

Table 6-5 details features and service provider benefits.

Table 6-5 ERX features and service provider benefits for cable subscriber management

ERX Features	Service Provider Benefits
Support for both DOCSIS and non-DOCSIS cable networks	Preserves existing investment in cable-modem equipment and supports integration of both standards-based and proprietary equipment into a common network
10x density of competing subscriber management platforms with support for 32,000 simultaneous IP sessions in a single chassis	Allows cable operators to cost effectively support multiple service areas from a single service platform
Integrates advanced subscriber management with next-generation routing	Reduces cost and space requirements over alternative subscriber management platforms that require an adjunct router
Scalable L3 performance and wire-speed forwarding	Allows cable operators to utilize low-cost layer 2 CMTSs at the hub and centralize routing and service delivery to increase operational efficiencies
Carrier-class reliability with NEBS-compliant hardware design, hot-swappable modules, and redundancy, and modular software architecture	Allows cable operators to offer SLAs with assurance of maximum uptime
Fine-grained, wire-speed IP QoS capabilities for up to 64,000 subscriber flows	Allows innovative IP services to be created for the entire subscriber base, including: <ul style="list-style-type: none"> • Throughput guarantees (maximum and minimum) • Preferred traffic treatment (Gold, Silver, Bronze) • Customer-specific traffic treatment • Application-specific traffic treatment

Table 6-5 ERX features and service provider benefits for cable subscriber management

ERX Features	Service Provider Benefits
Detailed statistics gathering for each subscriber and for each service, and support for RADIUS and IP-based accounting	Provides information required for bill generation and SLA reports, and integrates with current OSSs
Highly scalable and robust routing protocols developed to meet large-scale service provider needs: BGP-4, IS-IS, OSPF, and RIP	With ERX support for BGP-4 and IS-IS, service providers can offer broadband services from a network-peer platform, rendering two-stage B-RAS solutions obsolete
Ability to support logically separate virtual routers within a single chassis	Allows cable operators to securely route traffic targeted at different destinations to support an equal access model
Support for PPP, PPPoE, CHAP, PAP, DHCP, and RADIUS	Allows cable operators to roll out on-demand IP services using existing OSS infrastructure, greatly reducing the cost of adding new services while introducing new revenue streams
Access-agnostic network termination	Provides a consistent subscriber management and service delivery platform for all service applications, including cable, xDSL, wireless, and circuit aggregation

MPLS for Traffic Control

The ERX system supports the emerging MPLS standards to allow service providers to use this protocol tool for traffic engineering or VPN creation.

One of the uses for MPLS is to improve the IP traffic–engineering capabilities of the network by classifying and forwarding IP traffic into MPLS label-switched paths. MPLS allows service providers to control the path that the routed packets take, and can be used to optimize network resources and/or improve performance for a subset of network users. The traffic engineering can be coordinated with the core backbone network to achieve end-to-end traffic guarantees. A future promise for MPLS is to permit real-time upgrades of service quality based on congestion feedback. For example, if a given path were congested, all traffic would be diverted to another path.

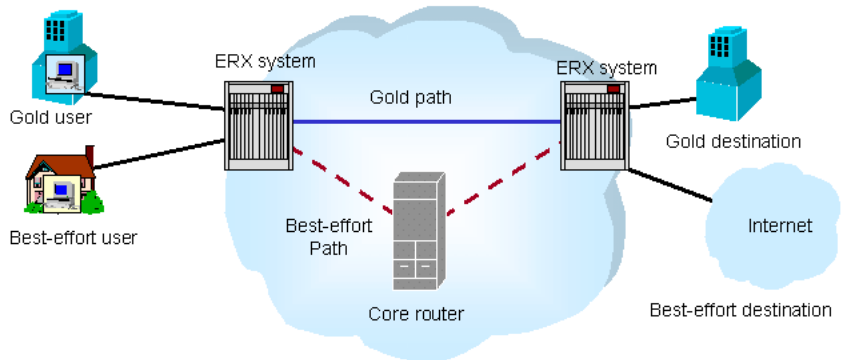

Figure 6-7 MPLS use for traffic engineering

In Figure 6-7, the ERX system is used to classify the incoming subscriber traffic and apply the appropriate MPLS label for “Gold path” or “best-effort path.” Depending on the applied label, the path taken through the network will vary. The core routers will use the label, not the underlying IP header information, to make forwarding decisions. In this way, the traffic can be engineered to travel over a certain predictable path. The MPLS paths are preconfigured as part of the network configuration, and each path can be engineered with varied bandwidth or latency guarantees.

The ERX platform’s unique hardware and software architecture supports full-performance, flexible QoS assignment. Any of the following classifications can be used to map the incoming flows into MPLS paths:

- Layer 3/layer 4 flow: Use the packet information from layer 3/layer 4 to assign the label-switched path (LSP)
- IP network prefix: Use the network source address to assign the LSP
- IP destination address: Use the IP address to forward the packet into the associated LSP

The ERX system supports a number of key features that allow service providers to implement MPLS in their network. See Table 6-6.

Table 6-6 ERX features and service provider benefits for MPLS for traffic engineering

ERX Features	Service Provider Benefits
MPLS labeling combined with fine-grained IP QoS classification	<ul style="list-style-type: none"> • Allows incoming packets to be mapped to MPLS paths with a wide range of classification options • Enables an edge device to classify and mark packets for proper handling by network core

Table 6-6 ERX features and service provider benefits for MPLS for traffic engineering

ERX Features	Service Provider Benefits
Wire-speed packet processing on all interfaces with ERX system ASIC technology	Enables wire-speed packet processing to deliver reliable QoS performance
Ability to support logically separate virtual routers within a single chassis	Allows service providers to securely route traffic targeted at different destinations (corporate VPN vs the Internet)
Detailed statistics gathering for each subscriber and for each service	Provides statistical information critical to network engineering design, build-out, and ongoing modifications

MPLS for VPNs

Another use for MPLS is to create IP-based VPNs: secure, logically partitioned private IP networks provisioned over a common, shared IP infrastructure. MPLS can provide the scaling, address management, QoS, security, reliability, and standards compliance required for VPN building. In this application, MPLS is used to map incoming traffic, based on the fields in the IP header or the source IP interface, onto specific MPLS-labeled paths across the backbone network. By mapping users to specific paths, service providers can isolate traffic between VPNs, providing the secure, reliable, and predictable behavior necessary to support VPN services. If the network needs to be re-engineered to maintain VPN support, the paths are moved.

In effect, the MPLS paths create “tunnels” through the network. The routers need to examine only the MPLS label to determine the packet path. This feature allows MPLS to alleviate the overlapping IP address problems often found in the creation of VPNs.

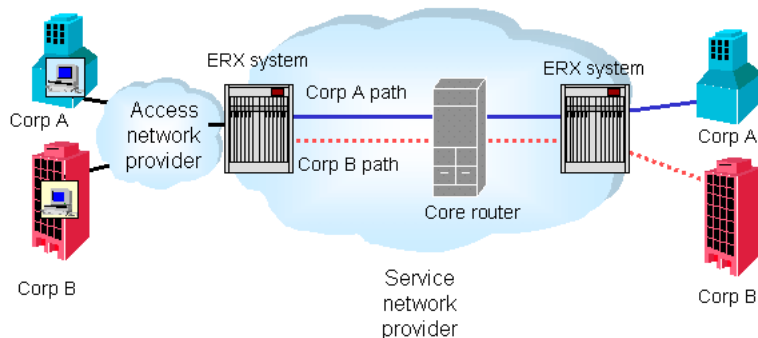

Figure 6-8 MPLS use for VPNs

As shown in Figure 6-8, the ERX system classifies the incoming packet and applies the appropriate MPLS VPN label at the network’s edge, where the subscriber packet first enters the service provider network. The traffic between the Corp A users and the Corp B users can be transported on separate paths through the network, guaranteeing secure operations and predictable performance. In addition, the MPLS label also optionally reserves bits to be used for QoS settings. These can be used to apply QoS parameters to the VPN path.

The ERX system supports a number of key features that allow service providers to implement MPLS in their network. See Table 6-7.

Table 6-7 ERX features and service provider benefits for MPLS for VPNs

ERX Features	Service Provider Benefits
MPLS labeling combined with fine-grained IP QoS classification	<ul style="list-style-type: none"> • Allows incoming packets to be mapped to MPLS paths with a wide range of classification options • Enables the edge device to classify and mark packets for proper handling by network core
Wire-speed packet processing on all interfaces with ERX ASIC technology	Enables wire-speed packet processing to deliver reliable QoS performance
Ability to support logically separate virtual routers within a single chassis	Allows service providers to securely route traffic targeted at different destinations (such as Corporate A vs Corporate B)
Detailed statistics gathering for each subscriber and for each service	Provides statistical information critical to network engineering design, build-out, and ongoing modifications

SLA Support

As service level agreements (SLAs) increasingly become a standard request from subscribers, service providers must be able to offer 100 percent uptime guarantees, with money-back penalties in cases of failure or noncompliance. In addition, the service provider must be able to demonstrate service quality to the subscriber in terms of reports and real-time access. The ERX system supports a number of key features that allow service providers to confidently offer SLAs to their subscribers. See Table 6-8.

Table 6-8 ERX features and service provider benefits for SLAs

ERX Features	Service Provider Benefits
Midplane architecture and 100% redundancy on all active cards	<ul style="list-style-type: none"> Allows for continuous operation even in failure conditions No cables to change means no technician intervention to maintain operation
Hot-swap capability on all active line modules	In case of failure, new modules can be inserted quickly without disrupting overall system operation.
Passive midplane and adapter modules	Minimizes need to replace these components; therefore, minimal need to move cables
Modular software design	Upgrades on individual software components can be performed with minimal impact on subscriber traffic.
Fine-grained statistics gathering for each subscriber and for each service	Allow statistics to be shared with subscribers to show service-level performance
CNM-architected NMS	Allows service providers to share information with subscribers in real-time
Sophisticated QoS policy control	Guarantees that subscribers' QoS settings are maintained

Non-IP Protocol Applications

Although the ERX system is optimized for IP traffic handling, two strategies are available to handle non-IP based packets:

- Apply MPLS labels to establish “tunneled” paths through the network. This allows non-IP protocols to be carried via MPLS. The MPLS label can be assigned to the packet based on the ingress or egress interface.
- Use the ERX system to offload the IP traffic from older performance-limited routing products. This allows the service provider to implement competitive, new IP-based policies to capture IP subscribers, while still meeting the needs of existing non-IP protocol customers.

VoIP Transport

The ERX system supports sophisticated QoS functionality that allows service providers to deliver tiered service levels to their subscribers. Tiered services offer different plans for different types of subscribers (Gold, Silver, Bronze) or plans that differentiate different traffic types (voice vs data). Figure 6-9 shows how separate data and voice services

can be delivered with a single ERX system. The ERX system can distinguish different applications as they enter the service provider edge network. Voice traffic can be treated as a priority, with corporate data and consumer data taking second and third place.

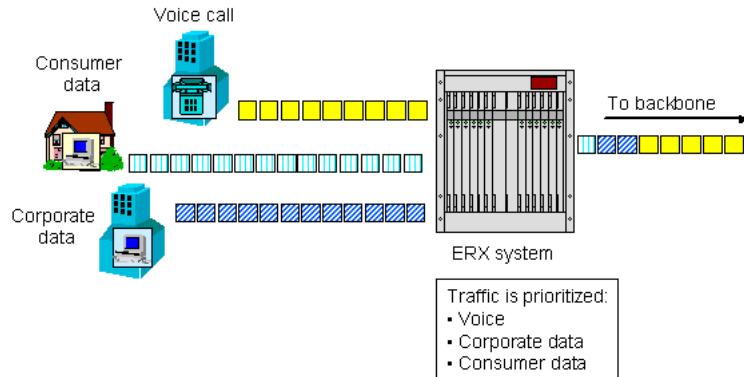

Figure 6-9 ERX system guarantees voice over IP (VoIP) traffic delivery

As packets enter the ERX system, they can be classified by any field in the IP header. This allows traffic to be separated by application. As shown in Figure 6-9, the traffic that enters the network can be classified by the ERX system, and different traffic types are given different treatment.



Note: The ERX system can be configured to honor packet classifications based on DS fields or MPLS labels if these are already set by CPE devices.

Once the packet is classified as VoIP, priority treatment can be guaranteed through the ERX system. For example, a specified latency can be guaranteed for VoIP packets classified as premium traffic, and a guarantee on uplink bandwidth can be made. As traffic leaves the ERX system, it can be stamped with a DS byte, or an MPLS label can be added. This indicates to the core network that the packet should receive priority treatment.

The ERX system supports a number of key features that are critical for priority traffic handling, as listed in Table 6-9.

Table 6-9 ERX features and service provider benefits for VoIP

ERX Features	Service Provider Benefits
Wire-speed packet processing	Allows QoS guarantees to be established. Without wire-speed processing, no QoS can be supported, since packets are queued before classification.
Support for 64,000 simultaneous queues	All user flows can receive individual, protected queues to guarantee QoS settings.

Table 6-9 ERX features and service provider benefits for VoIP (continued)

ERX Features	Service Provider Benefits
QoS resource guarantees	System resources and uplink bandwidth can be dedicated to varied service classes, reserving and protecting them for premium services.
Classification based on IP header fields or DS byte	Allows service providers to classify traffic based on application or to honor DS bits set by CPE devices
Virtual router support	Allows service providers to dedicate a separate logical router for higher-priority traffic
Packet marking (DS or MPLS)	Allows service providers to establish a premium policy at the edge of the network and properly mark the packet for treatment by the core device
Support for both strict-priority and rate-based scheduling	Supports guaranteed latency through the ERX system
Weighted scheduling	Supports tiered service offerings

Wholesaling

Many service providers lease portions of their facilities to other carriers; this practice is known as wholesaling. Strategies vary by service providers. Some offer “dark fiber” itself; others offer equipment; still others offer services that can be resold. The ERX system can offer wholesaling strategies where facilities-based service providers want to lease POP capacity to downstream carriers. As shown in Figure 6-10, a facilities-based service provider can use the ERX system to offer wholesale services to carrier partners.

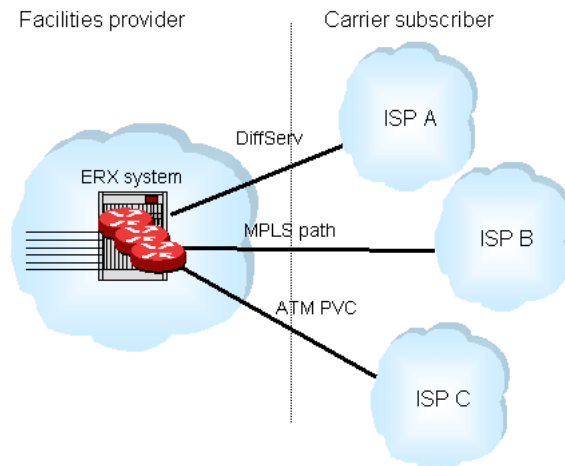

Figure 6-10 ERX system supporting wholesaling applications

The services can be delivered over a number of line speeds, including $n \times T1$, DS3, E3, OC3/STM1, and OC12/STM4, and a number of protocols, including PPP, Frame Relay, ATM, or POS.

With its support for virtual routers, the ERX system can allocate a completely logically separate router for each carrier subscriber. Each router can have its own routing table information, as well as its own protocols. For the facilities-based provider, virtual router support means that a single ERX system can support a variety of routers and route policies.

The ERX system can also support varied QoS policies for each carrier subscriber. This feature allows all providers to deliver QoS policies to their enterprise subscribers. Three options are shown in Figure 6-10: ISP A is using DiffServ to vary packet treatment; ISP B is using MPLS; and ISP C is using ATM PVC transport. The facilities-based provider can differentiate the packets and mark them with the appropriate QoS setting so that the rest of the network can process them accordingly.

The ERX system also supports policy control so that the facilities-based provider can protect itself from poor route distribution from its peers or subscribers.

The ERX system supports a number of key features that are critical for wholesaling applications, as shown in Table 6-10.

Table 6-10 ERX features and service provider benefits for wholesaling

ERX Features	Service Provider Benefits
High-capacity physical and logical density with support for thousands of interfaces in a single unit	Allows one ERX system to be shared cost effectively among multiple carrier subscribers
Carrier-class reliability	Allows SLAs to be offered to carrier subscribers and also passed onto their enterprise customers
IP QoS capabilities	Packets can be marked with DS or MPLS or dedicated to an ATM PVC to support end-to-end QoS policies for any carrier subscriber QoS implementation.
Virtual router support	Allows service providers to target different destinations for incoming subscribers, such as ISP A vs ISP B
Support for a variety of line speeds (DS0-OC12) and protocols (PPP/Frame Relay/ATM/POS)	<ul style="list-style-type: none"> • Supports all carrier subscriber environments with a single unit • Allows partners to sell a variety of services and/or remain compatible with existing infrastructures

End-to-End QoS

For a service provider to offer differentiated service levels, the entire network must be able to support and enforce QoS policies. End-to-end QoS can be supported in a multivendor environment with standards-based adherence. Figure 6-11 shows how QoS can be implemented over an entire network.

Figure 6-11 End-to-end QoS implemented over entire network

Each section of the network is responsible for a different QoS granularity. At the CPE end, QoS is assigned on an individual and/or application basis, with focus on delivering the most important traffic into the network over the typically bandwidth-constrained, expensive WAN pipes.

At the edge of the network, QoS policies are assigned by the service provider via the ERX system. These policies enforce QoS profiles for groups of subscribers relative to each other or for groups of applications relative to each other. Subscribers with premium QoS service plans receive more system resources or uplink bandwidth, or both. At the edge, oversubscription is typical, so subscribers will be in contention for resources. With QoS classification, the premium customers will receive premium treatment relative to other subscribers. Without QoS capabilities, all customers receive resource allocation in direct relation to how much traffic they send, not how much they deserve. The ERX system also tags the packets for proper treatment by the core.

In the core of the network, the routers and switches are concerned with maximum speed. Millions of customer flows are processed per second.

QoS service is handled in terms of service classes, such as DS byte settings, or MPLS paths, or ATM traffic type. The core handles the service class, making sure that premium classes receive premium treatment.

As traffic is handed back to the edge and CPE device, QoS policies can be applied again at the subscriber and individual user levels. The resulting coordination between the different elements allows for end-to-end QoS to be delivered to the subscriber.

The ERX system supports a number of key features that are critical for end-to-end QoS delivery. These features are listed in Table 6-11.

Table 6-11 ERX features and service provider benefits for end-to-end QoS

ERX Features	Service Provider Benefits
Standards-based compliance with DiffServ and MPLS	Allows for multivendor QoS implementation using best-of-breed products
Wire-speed packet processing	Allows QoS guarantees to be established. Without wire-speed processing, no QoS can be supported, since packets are queued before classification; this eliminates preferential treatment for priority traffic.
Support for 64,000 simultaneous queues	Allows all user flows to receive individual, protected queues to guarantee QoS settings
QoS resource guarantees	System resources and uplink bandwidth can be dedicated to varied service classes, reserving and protecting them for premium treatment traffic.
Classification based on IP header fields	Allows service providers to classify traffic based on source or destination address to assign QoS profiles and direct traffic to varied destinations
Virtual router support	Allows service providers to dedicate a separate, secure, logical router to different service providers' traffic
Packet marking (DS or MPLS)	Allows service providers to establish a QoS policy at the edge of the network and properly mark the packet for treatment by the core

VLAN Implementation

VLANs are used in the access network as well as in the core network. The most common scenario in the access network is “fiber to the curb” (FTTC). In this scenario, Ethernet runs all the way from the edge router (B-RAS) to the subscriber. Typically, an Ethernet switch, installed in the basement of a multitenant unit (MTU), tags the Ethernet frames of each customer before passing them onto the edge router. On the downlink, the Ethernet switch directs the tagged Ethernet frames to the port that

corresponds with the VLAN ID. Ethernet frames and broadcast packets remain in the same VLAN and cannot be seen by other VLANs.

On the Ethernet uplink facing the core network, VLANs are commonly used to logically segregate the traffic destined for services or service providers. VLANs are typically deployed in a hosted service environment. The access service provider can maintain a single and shared infrastructure for a variety of wholesale customers and applications without compromising SLA.

Figure 6-12 shows the ERX system in a VLAN application.

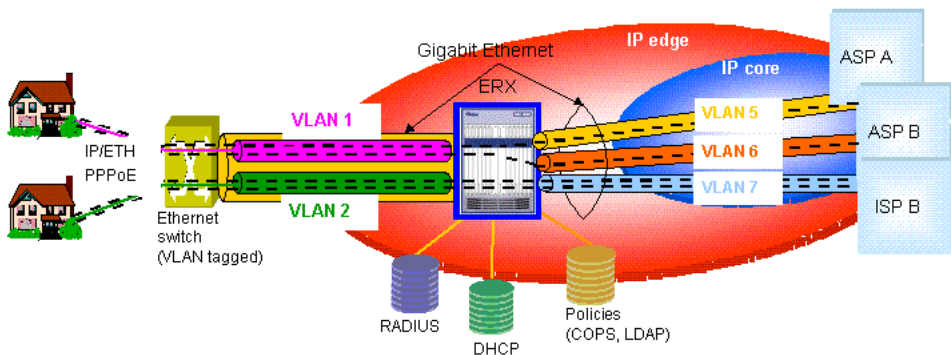

Figure 6-12 VLAN application with the ERX system

Fixed Wireless Applications

Fixed wireless applications refer to the operation of wireless devices in homes and offices, and in particular, equipment connected to the Internet via specialized modems. Common examples of wireless equipment in use today include cordless phones (not to be confused with cell phones), satellite television, and wireless LANs.

The ERX product family is the first fixed-wireless local loop (WLL) subscriber-access platform to deliver the performance, density, and scalability for comprehensive IP service delivery in large-scale fixed-wireless deployments. The ERX platform combines subscriber-access functions with Tier-1-class routing and innovative IP QoS to enable service providers to offer and deliver new, competitive IP services to their fixed-wireless subscribers.

Deployed by carriers in the central office or by service providers at a POP, the ERX transparently aggregates data traffic from multiple base stations to vendor-specific fixed-wireless implementations. Industry standard remote-access protocols such as PPP and RADIUS can be used to terminate point-to-multipoint and WLL base stations implementations

based on multichannel multipoint distribution system (MMDS), local multipoint distribution system (LMDS) and wireless LAN (WLAN). Direct connections from base stations or ATM, Frame Relay, or Ethernet aggregation switches (over SDH rings) are supported with E3/T3, OC3/STM1, OC12/STM4, and Fast Ethernet/Gigabit Ethernet (FE/GE) links. The output (egress) of the ERX platform is typically a high-speed link, such as OC3/STM1, OC2/STM4 and GE, to feed a core backbone.

In contrast to other products, the ERX system is a complete subscriber-access platform, providing both subscriber-access services as well as service profiles and IP-network routing. The ERX terminates the connection, manages the subscriber, applies IP services and routes, or forwards the traffic to the core. The ERX system handles all critical, fixed-wireless IP-edge functions as well as new and advanced features, including:

- PPP session termination and authentication via PAP or CHAP
- IP address assignment via DHCP, RADIUS, or local IP address pools
- Accounting data support via RADIUS to gather detailed billing information and bulk statistics via FTP
- Association of the subscriber with the service profile information via RADIUS server, domain name, or sophisticated packet classification
- Routing of session packets into the network via ATM, Frame Relay, IP- or PPP-based tunnels, or POS to the destination defined in the service profile

SMDS Application

The ERX system's SMDS implementation addresses an application in which the ERX system offloads the central express ring in an SMDS network. Figure 6-13 shows an SMDS network before ERX systems are added.

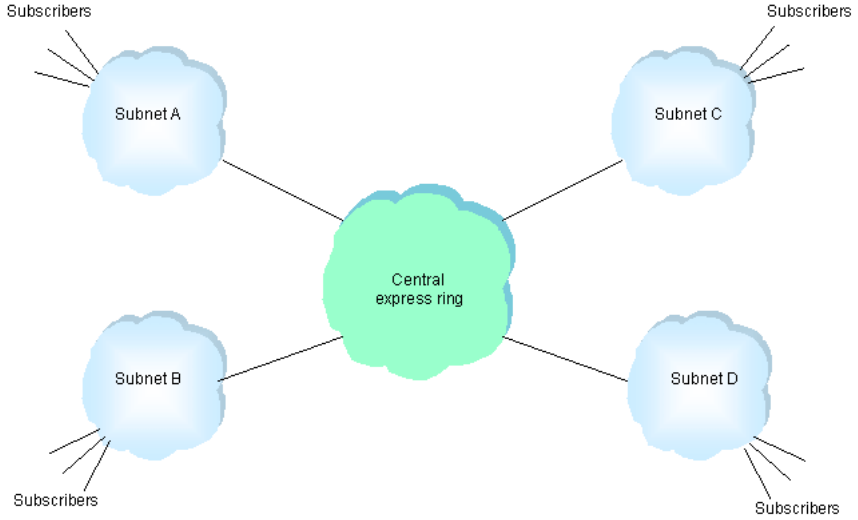

Figure 6-13 SMDS network with central express ring and subnets

As shown in Figure 6-14, the ERX system provides a mesh of GRE tunnel connections as a means of offloading the central express ring.

Figure 6-14 ERX system with GRE tunnels to offload the central express ring

To connect the GRE tunnels to each of the subnets, the ERX system connects to SMDS switches using the 3-port HSSI line module.

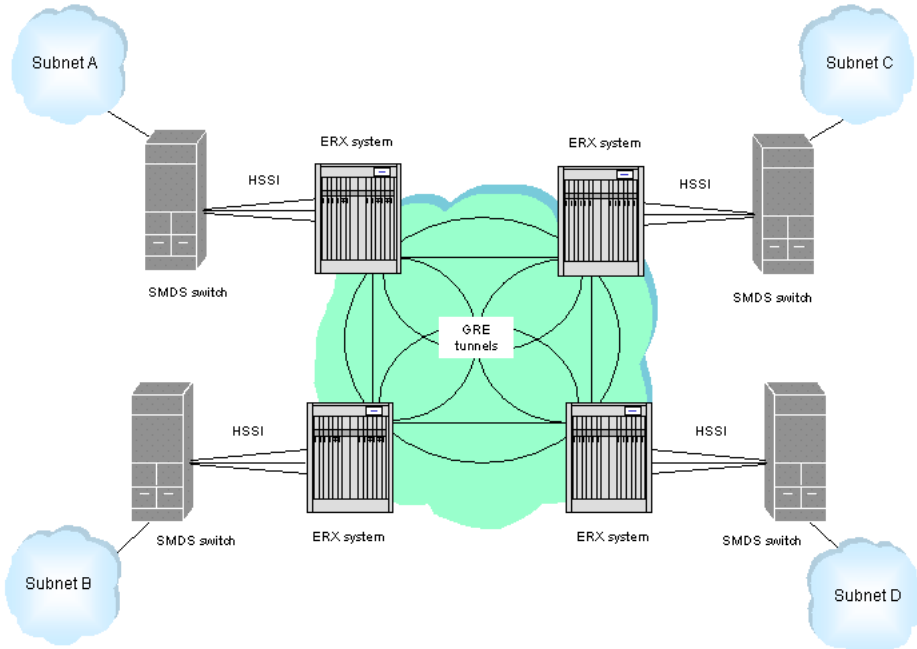

Figure 6-15 HSSI line modules in ERX systems provide connections to SMDS switches

