

ERX System Overview

1

This chapter provides information about the system.

Topic	Page
The ERX System	1-1
Where the ERX System Fits In	1-6
ERX System Modules	1-7
Network Management Tools	1-11
Redundancy Features	1-11
The Next Step	1-15

The ERX System

The ERX edge routers are modular, carrier-class networking devices that deliver performance, reliability, and service differentiation to both business and consumer Internet users. The systems offer high port density, low power consumption, and fully redundant Internet access routing and edge aggregation. The ERX edge routers offer the complete edge solution for IP-optimized carriers.

Four models of the ERX edge router are available:

- ERX-1440 system
- ERX-1410 system
- ERX-705 system
- ERX-700 system

All models use the same software. However, the specific model determines:

- The combination of line modules supported
- The conditions for line rate performance of line modules

ERX-1400 Series

In the ERX documentation, the term ERX-1400 series refers to both the ERX-1440 system and the ERX-1410 system. The terms ERX-1440 system and ERX-1410 system refer to the specific models.

The ERX-1440 system manages an extremely high volume of network traffic and uses a 40-Gbps switch route processor (SRP) module, either the SRP-40G or SRP-40G+ module. (The SRP-40G+ module obsoletes the SRP-40G module; however, the software continues to support both modules.) In this model, all line modules operate at full wire speed simultaneously.

The ERX-1410 system manages high levels of network traffic, and uses the 10-Gbps SRP module (SRP-10G). You can configure the ERX-1410 system to enable the line modules either to operate at full line rate performance or to allow line modules to operate at a rate dependent on the resources available. The former option restricts the allowed combinations of line modules. For information on configuring performance of line modules, see *ERX System Basics Configuration Guide, Chapter 5, Managing Line Modules and SRP Modules*.

Externally, the ERX-1440 chassis is the same as the ERX-1410 chassis (see Figure 1-1 and Figure 1-2). Both systems contain fourteen vertical slots to accommodate modules and have the same power requirements. Installation procedures and operating procedures are identical for both systems. All ERX systems use the same SRP I/O modules.



Note: *The system may look different from the systems shown in the figures in this chapter, depending on the line modules in the slots.*

Internally, the ERX-1440 chassis differs from the ERX-1410 chassis, and includes a special midplane for the 40-Gbps SRP module.

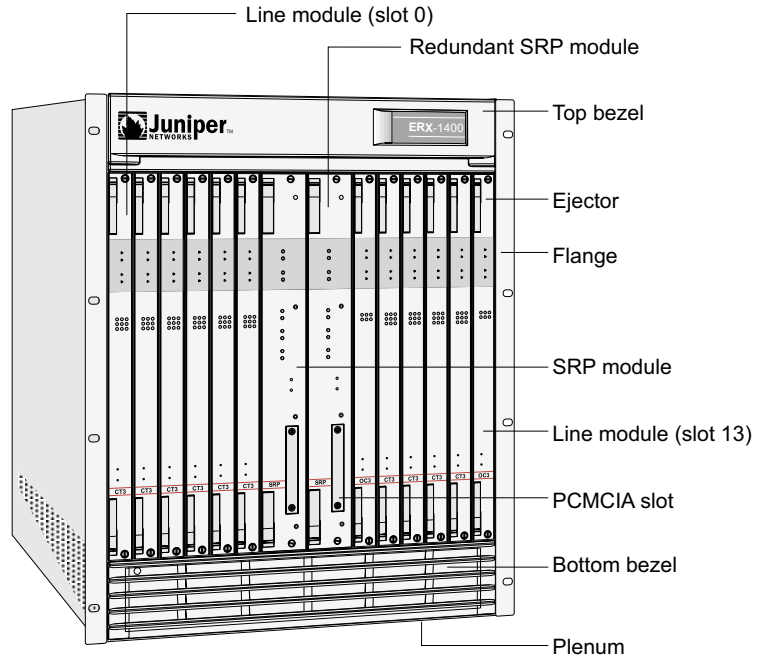

Figure 1-1 ERX-1400 series front view

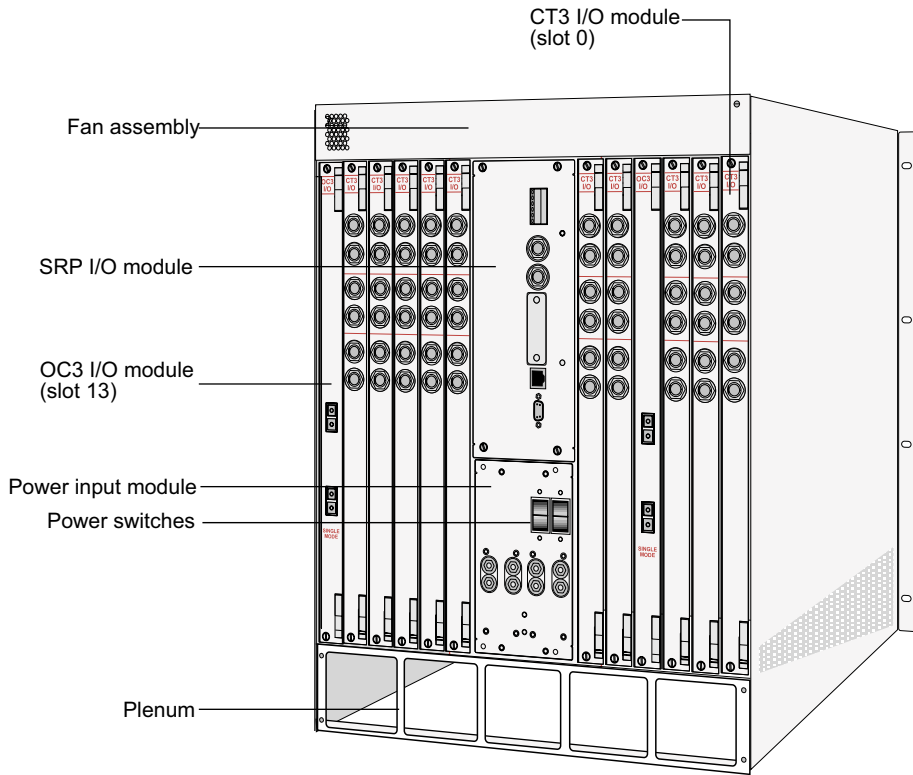

Figure 1-2 ERX-1400 series rear view

ERX-700 Series

In the ERX documentation, the term ERX-700 series refers to both the ERX-705 system and the ERX-700 system. The terms ERX-705 system and ERX-700 system refer to the specific models.

The ERX-705 system is a compact, high-performance model that manages low traffic density and uses a 5-Gbps SRP module, the SRP-5G+ module. The ERX-700 system is a robust, high-density system with less capacity than the ERX-1400 series. The ERX-700 system uses either the SRP-10G module or a 5-Gbps SRP module, the SRP-5G module. (Although the SRP-5G+ module obsoletes the SRP-5G module; the software continues to support both modules.)

You can configure the ERX-700 series to enable the line modules either to operate at full line rate performance or to operate at a rate dependent on the resources available. For information about configuring performance of line modules, see *ERX System Basics Configuration Guide, Chapter 5, Managing Line Modules and SRP Modules*.

The ERX-705 chassis is the same as the ERX-700 chassis (see Figure 1-3 and Figure 1-4). The chassis contains seven slots to accommodate modules. Installation procedures and operating procedures are identical for both systems. All ERX systems use the same SRP I/O modules.



Note: The system may look different from the systems shown in the figures in this chapter, depending on the line modules in the slots.

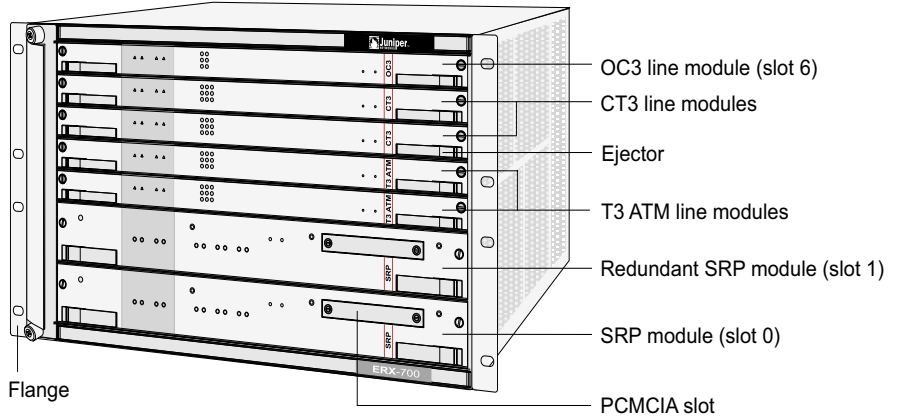

Figure 1-3 ERX-700 series front view

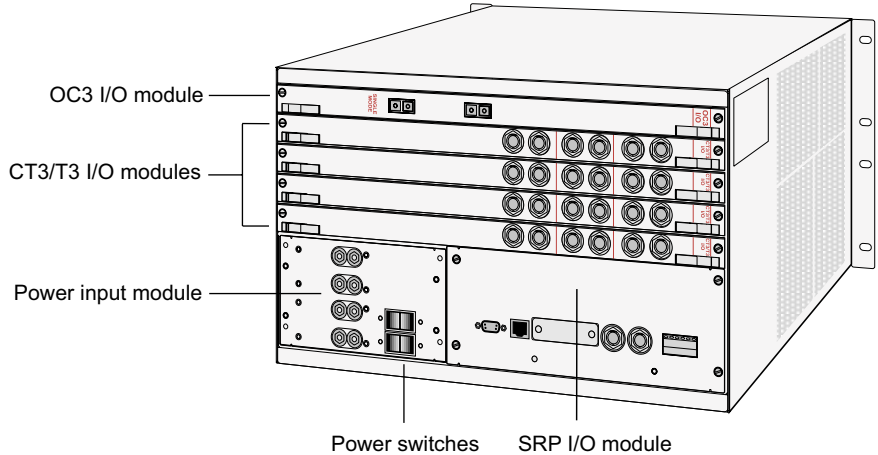

Figure 1-4 ERX-700 series rear view

Where the ERX System Fits In

Figure 1-5 and Figure 1-6 illustrate the position of the system as an edge router in an end-to-end Internet network. Communications with the system can take place over a variety of media. In Figure 1-5, the customers are businesses using T1/T3 communication lines. In Figure 1-6, the customers are using digital subscriber lines (DSLs) with a DSL access multiplexer (DSLAM).

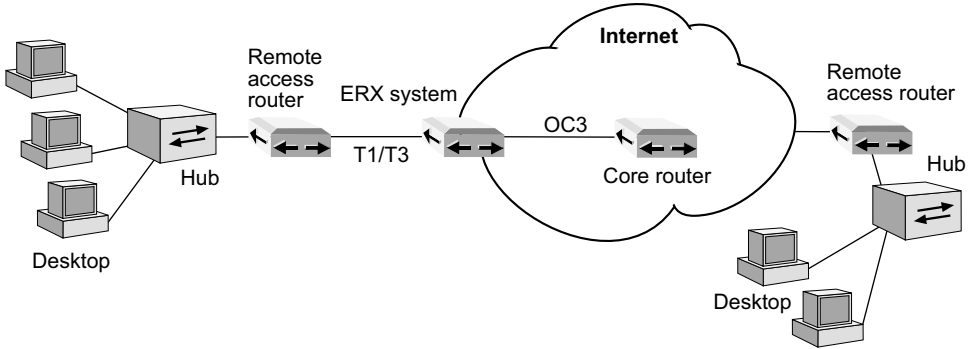

Figure 1-5 ERX system communicating over T1/T3 lines

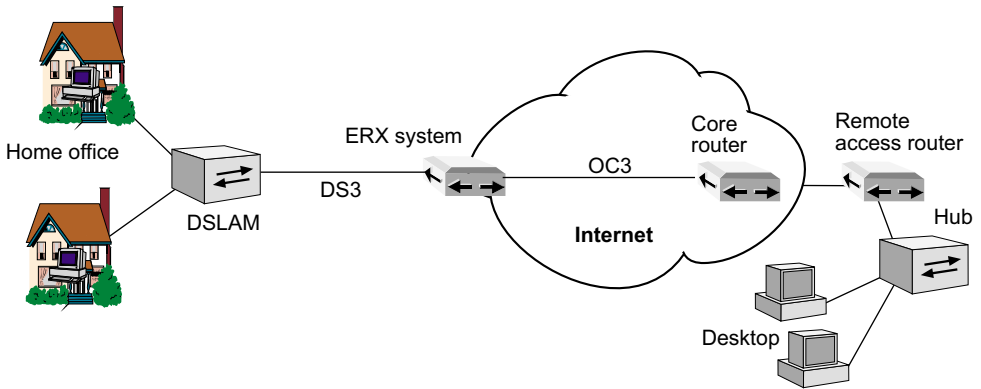

Figure 1-6 ERX system communicating over DSL lines

ERX System Modules

The system supports an SRP module and a selection of line modules. You can use any line module for *access* or *uplink*. Access line modules receive traffic from low-speed circuits, and the system routes the traffic onto higher-speed uplink line modules and then to the core of the Internet.

Each module connects to a corresponding I/O module via a passive midplane. See Figure 1-7.

The front panel of each system module contains a collection of status LEDs (light-emitting diodes). See Figure 1-8. For information about how to interpret the LEDs, see *Chapter 8, Troubleshooting*.

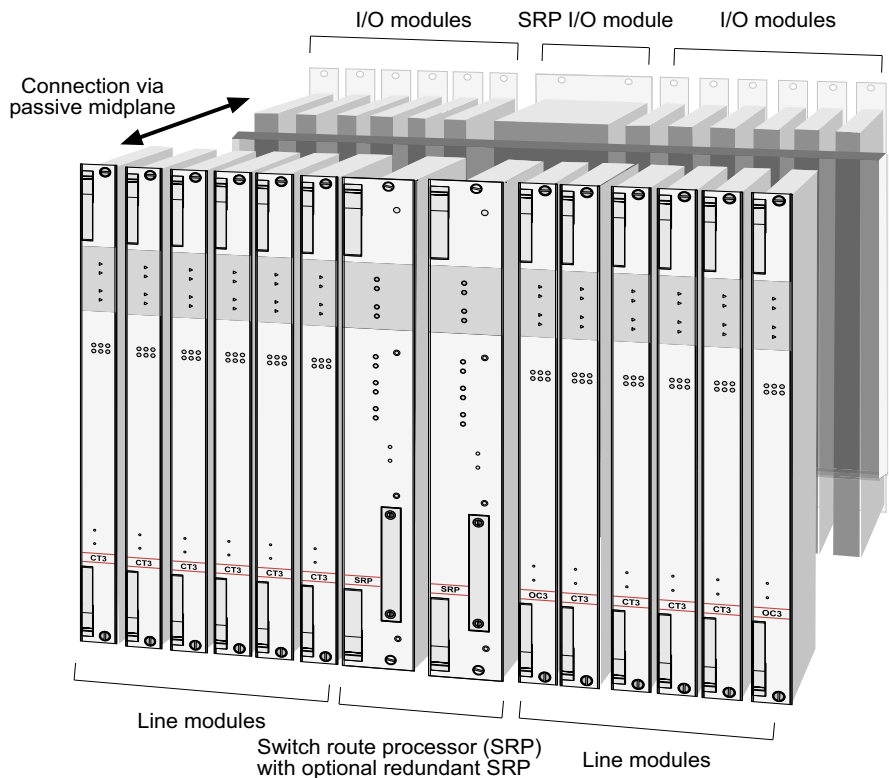

Figure 1-7 Modules in the ERX-1400 series

SRP Module

The SRP module (see Figure 1-8) is a two-board assembly; both boards connect to the system's midplane and to each other:

- The fabric board is a switch fabric server that queues packets for the line modules. The fabric server houses a flexible hardware queuing resource that empowers IP QoS for each physical and logical interface, providing weighted scheduling for preferential packet delivery.
- The system processor board is the dedicated processor that boots the system, manages diagnostics, and supports routing protocol processing.

An SRP module must be present for the system to boot. For details about installing SRP modules, see *Chapter 3, Installing ERX Modules*. For specifications of SRP modules, see *Appendix B, Module Specifications*.



Caution: Do not remove the SRP module while the system is running.

You can install two SRP modules of the same type in the system. If you do, the first SRP module serves as the primary; the second as a redundant module, which enhances the system's reliability. See *Redundancy Features*, later in this chapter.

Nonvolatile Storage

The PCMCIA slot on the front of the SRP module holds a Type II PCMCIA nonvolatile storage (NVS) card. This card retains the system's configuration and software. See Figure 1-8. The PCMCIA card is factory installed.

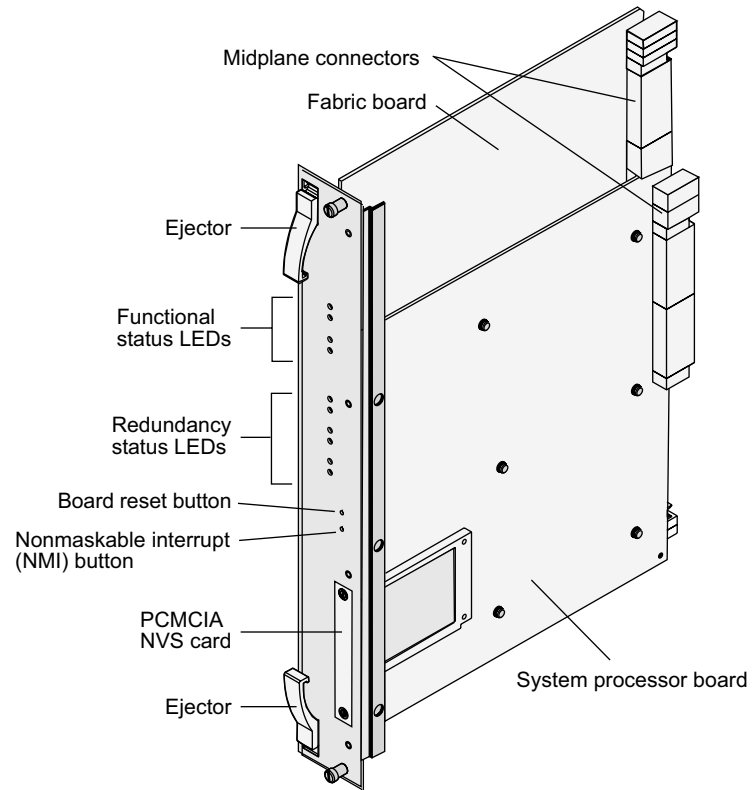

Figure 1-8 SRP module

SRP I/O Module

A single corresponding input/output module called the SRP I/O module interfaces with one or two SRP modules through the system's midplane. The same SRP I/O works with all models of the SRP module. This I/O module is two slots wide. See Figure 1-2 and Figure 1-4.

The SRP module provides standard craft management interfaces, including:

- 10/100Base-T – a port for Ethernet management
- RS-232 – a port for VT100 management access
- External timing inputs – ports for external timing sources

For details about installing the SRP I/O module, see *Chapter 3, Installing ERX Modules*.

Line Modules

Line modules process data from different types of network connections. For information about the available line modules and which SRP modules support specific line modules, see *Appendix B, Module Specifications*.

Figure 1-9 shows a representative line module. For details about installing line modules, see *Chapter 3, Installing ERX Modules*.

Packet Classification

Each line module supports packet classification on ingress. A classification engine on the line module matches specific fields (such as source and destination IP address, source and destination port, and protocol), the ingress IP interface, layer 2 fields, or some combination of these against user-configured filters at wire speed.

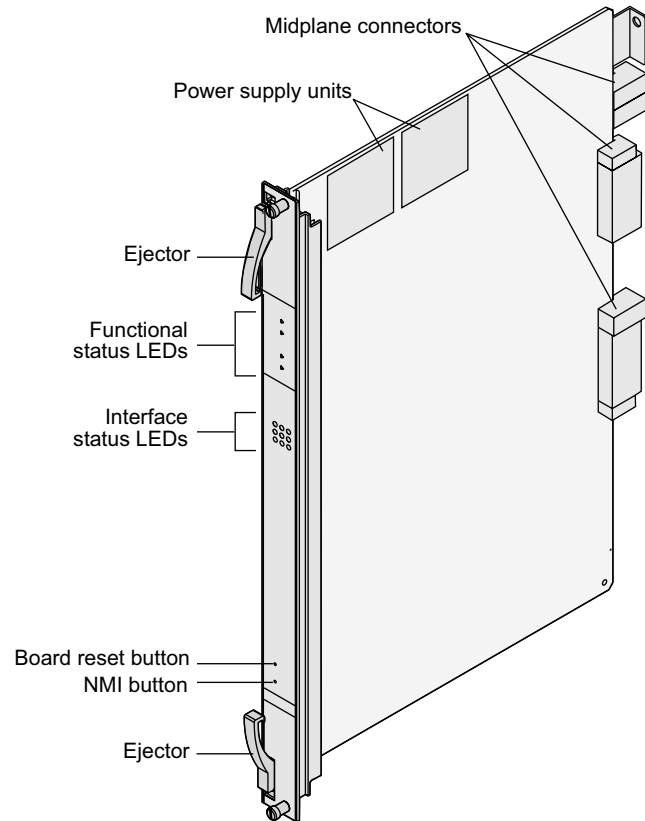

Figure 1-9 Representative line module

I/O Modules

Most line modules have a corresponding input/output (I/O) module that provides the physical interconnection to the network. Insert each I/O module in the back of the system, directly behind its corresponding line module. For information about which line modules pair with which I/O modules, see *Appendix B, Module Specifications*. For details about installing I/O modules, see *Chapter 3, Installing ERX Modules*.

Network Management Tools

You can use different management tools to configure the system to meet the specific networking requirements.

CLI Management

The CLI provides fully developed and automated configuration and status functionality through a local RS-232 port, an Ethernet connection, or Telnet through any reachable network. For a full discussion of the CLI, see *ERX System Basics Configuration Guide, Chapter 2, Command Line Interface*.

SNMP MIB Management

The system offers a complete SNMP interface for configuration, status, and alarm reporting. The system supports both Standard and Enterprise MIBs (Management Information Bases). The ERX Enterprise MIB is ASN.1 notated for easy importing into third-party SNMP management applications. For more information, see *ERX System Basics Configuration Guide, Chapter 3, Configuring SNMP*.

NMC-RX Device Management System

The NMX-RX application provides a global method of managing all edge routers, line modules, and ports.

Redundancy Features

The system has the following redundancy features:

SRP Modules

The SRP module uses a 1:1 redundancy scheme. When two SRP modules of the same type are installed in the system chassis, one acts as a primary and the second as a standby. Both SRP modules share a single SRP I/O

module located in the rear of the chassis. If the primary SRP fails, the redundant SRP module assumes control without rebooting or initializing itself. (As a consequence, if you upgrade software, you must copy the software to the redundant SRP and reboot it.) For information about configuring and managing SRP module redundancy, see *ERX System Basics Configuration Guide, Chapter 5, Managing Line Modules and SRP Modules*.

After you install two SRP modules, the modules negotiate for the primary role. A number of factors determine which module becomes the primary; however, preference is given to the module in the lower-numbered slot. The SRP modules record their latest roles and retain them the next time you switch on the system. For information about installing SRP modules, see *Chapter 3, Installing ERX Modules*.

NVS Cards

If you have two SRP modules installed in a system, you can use NVS cards of different capacities on the SRP modules. The effective capacity of the higher-capacity NVS card will equal that of the lower-capacity NVS card. For information about installing NVS cards, see *Chapter 3, Installing ERX Modules*.

When you install new NVS cards or SRP modules, you must issue the **synchronize** command to match the file system of the NVS card on the redundant SRP module with the file system of the NVS card on the primary SRP module. (The NVS card on the redundant SRP module will hereafter be referred to as the redundant NVS card; the NVS card on the primary SRP module will hereafter be referred to as the primary NVS card.)

If the capacity of the primary NVS card is equal to or smaller than that of the redundant NVS card, the system copies all the files from the primary NVS card to the redundant NVS card. However, if the capacity of the primary NVS card exceeds that of the redundant NVS card, the system creates an invisible synchronization reserve file on the primary NVS card, provided that there is enough space for the file.

The purpose of the synchronization file is to prevent the creation of data that will not fit on the redundant NVS card. The file contains no useful data, and is not visible when you view the files in NVS. The size of the file is equal to the difference in capacities of the two NVS cards. For example, if the primary NVS card has a capacity of 224 MB, and the redundant NVS card has a capacity of 220 MB, the size of the synchronization file is 4 MB, and only 220 MB of space is available on the primary NVS card.

If there is not enough space on the primary NVS card to create the synchronization reserve file, the **synchronize** command fails, and you see a warning message on the console. To resolve this issue, either delete unwanted files from the primary NVS card or replace the redundant NVS card with a higher-capacity NVS card.

Line Modules

The ERX system supports line module redundancy for several line modules. For details about which line modules support redundancy, see *Appendix B, Module Specifications*. In this scheme, an extra line access module in a group of identical line modules provides redundancy in case of line module failure. To use this feature, you need a:

- Spare line module
- Redundancy midplane
- Redundancy I/O module

A redundancy midplane may cover 2–6 slots. It provides additional connectivity that enables the spare line module to assume control of the I/O module associated with any failed line module in the redundancy group. The spare I/O module provides connectivity from the spare line module to the redundancy midplane.

The process by which the system switches to the spare line module is called *switchover*. When switchover occurs, the system:

- 1 Breaks the connection between the primary I/O module and the primary line module.
- 2 Connects the primary I/O module to the spare line module via the redundancy midplane and redundancy I/O module.

Protocol processing then takes place on the spare line module.

Figure 1-10 shows the data flow when a spare line module becomes active.

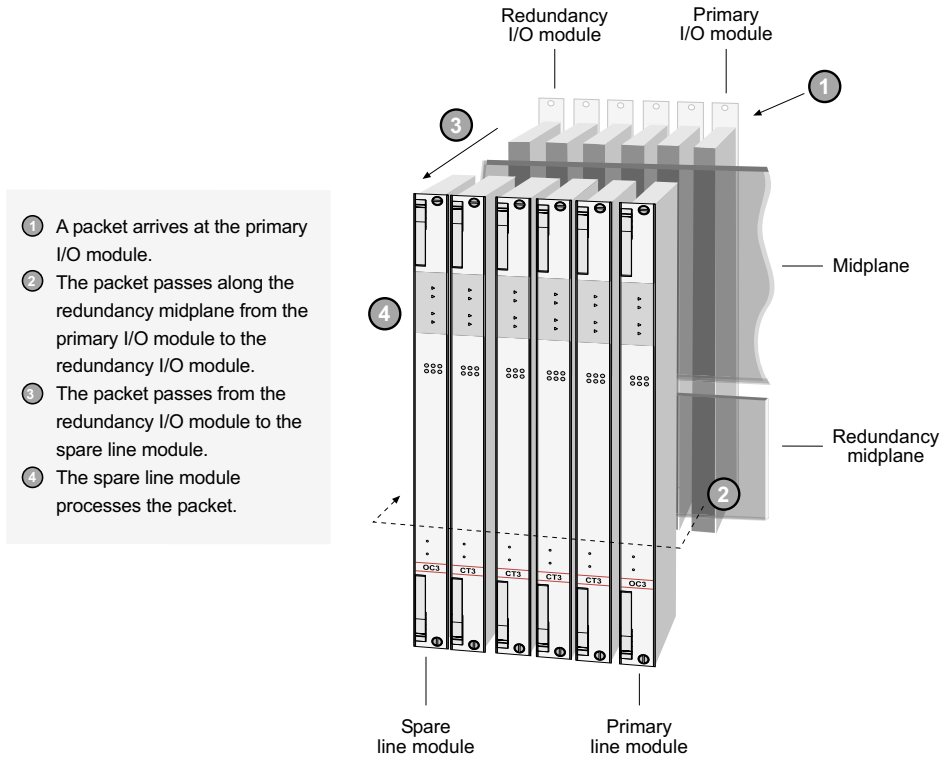

Figure 1-10 Data flow when a spare line module is active

For information about installing modules for line module redundancy, see *Chapter 3, Installing ERX Modules*. For information about configuring and managing SRP module redundancy, see *ERX System Basics Configuration Guide, Chapter 5, Managing Line Modules and SRP Modules*, for more information.

Power

The system provides a power architecture that distributes redundant –48 VDC feeds through the system to each line module, SRP module, and fan module where DC-to-DC converters provide local conversion to the required secondary voltages. The system design prevents a failure of any one of the power components from causing any other component in the system to fail.

Fans

Forced air-cooling keeps the temperature of the ERX modules and components within normal operating limits. In the ERX-1400 series, six cooling fans are located in a tray at the top of the system (see Figure 7-1). In the ERX-700 series, four cooling fans are located in a tray on one side of the system (see Figure 7-7).

The system monitors the temperature of each module. If the temperature of a module exceeds the maximum limit, the system immediately goes into thermal protection mode. In this mode, the modules consume extremely low levels of power. For information about troubleshooting high operating temperatures, see *Chapter 8, Troubleshooting*.

The fan tray has two redundant converters that power the fans (for the ERX-1400 series, a –24 V, 50 W converter; for the ERX-700 series, a –12 V, 15 W converter). If one converter fails, the other takes over. In addition, the system software reports an alarm if any of the fans overrotate or underrotate or if one of the converters fails.

The Next Step

Go to *Chapter 2, Installing the ERX System*.

