

Maintaining the ERX System

7

This chapter describes the procedures that you must complete to maintain the ERX system and its components. Other maintenance procedures must be performed by an authorized Juniper Networks technician.

Topic	Page
Required Tools and Items	7-1
Storing Modules and Components	7-2
Upgrading NVS Cards on SRP Modules	7-2
Replacing SFPs on GE I/O Modules	7-5
Cleaning the System	7-9
Replacing Fan Trays	7-9

Required Tools and Items

You will need the following tools and other items to replace ERX components.

- Flathead and Phillips screwdrivers
- Insulated adjustable wrench
- Antistatic wrist strap
- Antistatic bags (or other protective packaging to hold components)

Storing Modules and Components



Caution: Failure to store electronic modules and components correctly may lead to damage of these items.

Retain the packaging in which a module or component was shipped, and use this packaging to store the item. Modules are shipped in antistatic bags and protective packaging. Components, such as transceivers and NVS cards, are shipped in antistatic plastic containers within an antistatic padded box. Follow these guidelines for storing modules and components:

- Store each module in a separate antistatic bag.
- Store components in an antistatic plastic container. Some of these containers can accommodate several components in separate compartments.
- Do not store multiple modules or components in an antistatic bag or container where they can touch other items.
- (Optional) Store the item in its antistatic bag or container within the protective packaging or padded box that the item was shipped in.

Upgrading NVS Cards on SRP Modules

This section describes how to install higher-capacity NVS cards on SRP modules. The procedure you use depends on the number of SRP modules in the system. A new NVS card will contain the software release you ordered.



Note: The new NVS card must contain the same software release that you are running on the system.

Upgrading a System That Contains One SRP Module

If the system contains only one SRP module, you must power down the system before you upgrade the NVS card. To upgrade the NVS card on a system that contains one SRP module:



Caution: If you do not use the **halt** command before removing or powering down an SRP, the system's NVS card may become corrupted.

- 1 Enter the **halt** command.

See *ERX System Basics Configuration Guide, Chapter 5, Managing Line Modules and SRP Modules* for information about the **halt** command.



Warning: Do not insert any metal object, such as a screwdriver, or place your hand into an open slot or the backplane when the ERX system is on. Remove jewelry (including rings, necklaces, and watches) before working on equipment that is connected to power lines. These actions prevent electric shock and serious burns.



Caution: When handling modules, use an antistatic wrist strap connected to the ERX system's ESD grounding jack. This action helps to protect the module from damage by electrostatic discharge.

- 2 Connect the antistatic wrist strap to the ESD grounding jack on your ERX system.
- 3 Power down the system (see *Chapter 6, Powering Up the System*).
- 4 Remove the SRP I/O module.
- 5 Replace the NVS card on the SRP module (see *Replacing an NVS Card*, later in this chapter).
- 6 Power up the system (see *Chapter 6, Powering Up the System*).

Upgrading a System That Contains Two SRP Modules

In a system that contains two SRP modules, you can upgrade the NVS cards on the SRP modules without powering down the system.



Warning: Do not insert any metal object, such as a screwdriver, or place your hand into an open slot or the backplane when the ERX system is on. Remove jewelry (including rings, necklaces, and watches) before working on equipment that is connected to power lines. These actions prevent electric shock and serious burns.



Caution: When handling modules, use an antistatic wrist strap connected to the ERX system's ESD grounding jack. This action helps to protect the module from damage by electrostatic discharge.

To upgrade the NVS cards on the SRP modules in a system that contains two SRP modules:

- 1 Connect the antistatic wrist strap to the ESD grounding jack on your ERX system.
- 2 Reboot the redundant SRP module.

```
host1#reload slot 6
```
- 3 Immediately remove the redundant SRP module from the chassis.
- 4 Replace the NVS card on this SRP module (see *Replacing an NVS Card*, later in this chapter).
- 5 Reposition the SRP module into the chassis.

- 6 When this SRP module is available, synchronize the SRP modules.
`host1#synchronize`
- 7 When the SRP modules are synchronized, reboot the SRP module that you upgraded.
`host1#reload slot 6`
- 8 When this SRP module is available, synchronize the SRP modules.
`host1#synchronize`
- 9 When the SRP modules are synchronized, force the redundant SRP module to take over from the primary SRP module.
`host1#srp switch`
- 10 Immediately remove the former primary SRP module.
- 11 Repeat steps 4–8 for the former primary SRP module.

Replacing an NVS Card

To replace an NVS card on an SRP module:

- 1 Obtain an antistatic container for the NVS card you will remove (see *Storing Modules and Components*, earlier in this chapter).
- 2 With a small flathead screwdriver, remove the faceplate from the NVS card slot on the SRP module (see Figure 7-1).
- 3 Use the screwdriver to depress the button next to the NVS card (see Figure 7-1).

This action releases the NVS card.

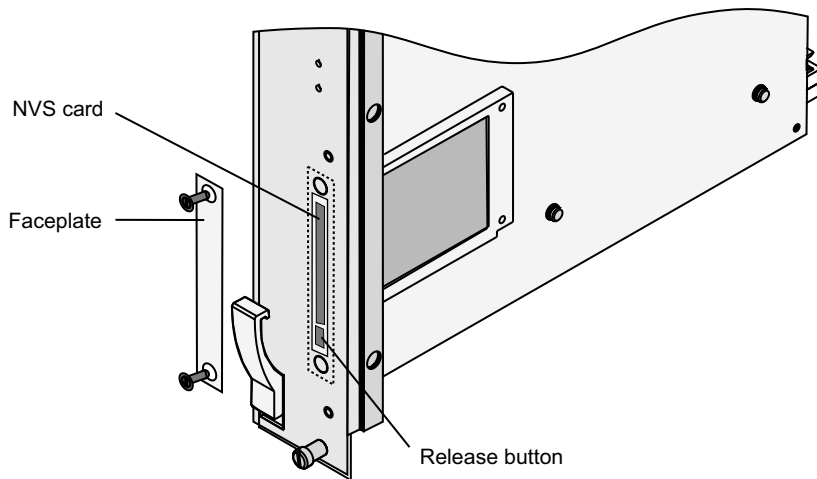

Figure 7-1 NVS card slot on SRP module

- 4 Remove the NVS card and place it in the antistatic container.
- 5 Insert the higher-capacity NVS card into the slot.
- 6 Push the higher-capacity NVS card as far as you can in the slot.
When you push the card far enough, it will click into place.
- 7 Replace the faceplate on the NVS card slot.

Replacing SFPs on GE I/O Modules

This section describes how to replace small form-factor pluggable transceivers (SFPs) on Gigabit Ethernet (GE) modules that support these devices. A range of SFPs that support different optical modes (multimode and single mode) and cabling distances is available. You can replace the SFPs without disabling the interfaces or removing the module from the system.



Warning: Do not insert any metal object, such as a screwdriver, or place your hand into an open slot or the backplane when the ERX system is on. Remove jewelry (including rings, necklaces, and watches) before working on equipment that is connected to power lines. These actions prevent electric shock and serious burns.



Caution: When handling electronic components, use an antistatic wrist strap connected to the system's ESD grounding jack, and hold components by their edges. Do not touch, pins, leads, or solder connections. Store components in antistatic bags. These actions help to protect modules from damage by electrostatic discharge.

Removing SFPs

To remove the SFPs:

- 1 Obtain an antistatic container for the SFPs you will remove (see *Storing Modules and Components*, earlier in this chapter).
- 2 Put the antistatic wrist strap on your wrist, and connect the strap to the ESD grounding jack on the system.
- 3 Disconnect the cables from one of the SFPs on the module.
- 4 Identify the release mechanism for the SFP.

Different SFPs use different release mechanisms (see Figure 7-2).

Possible release mechanisms include:

- A button that you press inward
- A ring that you press inward
- A bar that you pull sideways, then outward
- A tab that you pull sideways, then outward

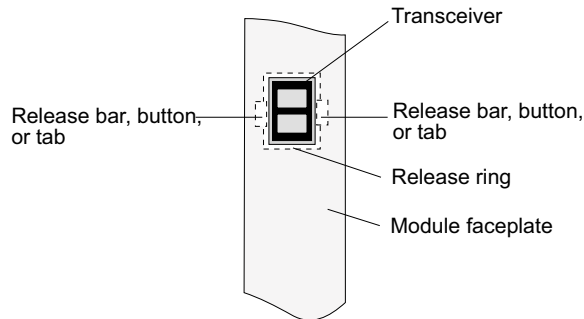

Figure 7-2 Possible release mechanisms on the SFP

- 5 Release the SFP and pull it out of the slot.
- 6 Place the SFP in an antistatic bag.
- 7 If you are using the redundant port on the ERX GE I/O module, repeat steps 3 through 6 for the other SFP.



Caution: For port redundancy to operate correctly, both the primary and redundant ports on an ERX GE I/O module must use the same type of SFP.

Installing SFPs

To install SFPs:

- 1 Put the antistatic wrist strap on your wrist, and connect the strap to the ESD grounding jack on your system.
- 2 Identify the following items on the SFP (see Figure 7-3):

- The connection circuitry on the base
- The cable connectors on the front

The cable connectors will be protected by a dust cover.

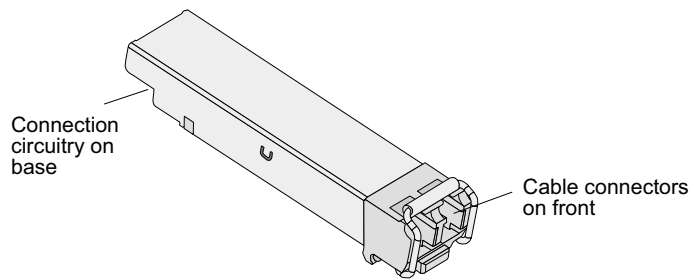

Figure 7-3 Example of SFP



Caution: Be sure to position the SFP correctly before you install it.

- 3 Hold the SFP so that:
 - The connection circuitry is adjacent to the TX and RX markings on the module's faceplate.
 - The front will be visible when you install the SFP.

For a picture of the correct orientation, see Figure 7-4.

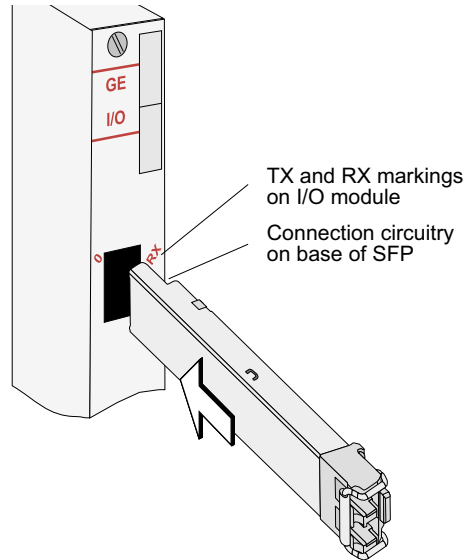

Figure 7-4 Installing an SFP on an ERX GE I/O module

- 4 Insert the SFP as far as you can into the I/O module.
The SFP should slide smoothly into the I/O module and should click into place. If the SFP does not slide smoothly into the I/O module, check that the orientation of the SFP is correct.
- 5 Gently pull the SFP to confirm that it is inserted correctly.
The SFP should not move when you pull it. If the SFP comes out of the slot when you pull it, repeat step 4.
- 6 Remove the dust cover that protects the ports.
- 7 Connect the new cables to the SFP.

If you are using the redundant port on the ERX GE I/O module, repeat steps 2 through 7 for the other port.

Verifying the Installation

When you have replaced the SFPs and connected the cables, issue the **show interface gigabitEthernet** command for each interface to check that the interface is operational (up).

- Field descriptions
 - › `gigabitEthernet interfaceSpecifier` – status of the hardware on this interface
 - up – hardware is operational
 - down – hardware is not operational
 - › Administrative status – operational state that you configured for this interface
 - up – interface is enabled
 - down – interface is disabled
- Example

```
host1:vr2#show interfaces gigabitEthernet2/0
gigabitEthernet2/0 is Up, Administrative status is Up
```

Cleaning the System



Warning: Do not insert any metal object, such as a screwdriver, or place your hand into an open slot or the backplane when the ERX system is on. Remove jewelry (including rings, necklaces, and watches) before working on equipment that is connected to power lines. These actions prevent electric shock and serious burns.



Caution: When cleaning the system, wear an antistatic wrist strap connected to the system's ESD grounding jack. This action helps to protect modules from damage by electrostatic discharge.

Dust is attracted to the side of the system on which the air intake vent is situated (see Figure D-2). Clean this side of the system with a dry cloth every couple of weeks to prevent excessive accumulation of dust. This cleaning will maintain the efficiency of the cooling system and prevent damage to electronic components.

Replacing Fan Trays

A tray of cooling fans provides forced air cooling for components in the ERX-1400 series and ERX-700 series. The location of the fans depends on the model. The ERX-700 series and ERX-1400 series support hot-swapping of the fan tray. Hot-swapping allows you to replace the fan tray without powering down the system. However, if you do not replace the fan tray within a few minutes, the system will go into thermal protection mode. For information about thermal protection mode, see *Monitoring Temperatures of Modules* in *Chapter 8, Troubleshooting*.



Caution: If the FAN FAIL LED on the SRP module is illuminated and none of the fans are spinning when you remove the fan tray, power down the system until a new fan tray is available. Operating an ERX system with inadequate air circulation may damage the modules.

ERX-1400 Series

Figure 7-5 and Figure 7-6 show the location of the fan tray in the ERX-1400 series.

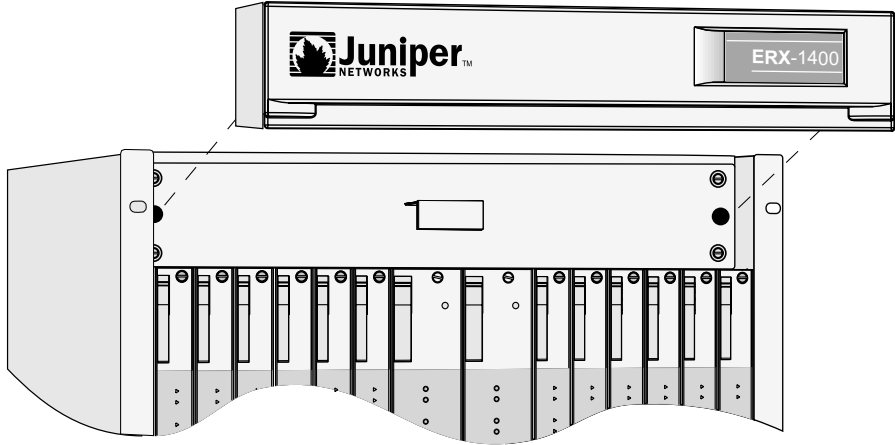

Figure 7-5 Location of fan tray in ERX-1400 series

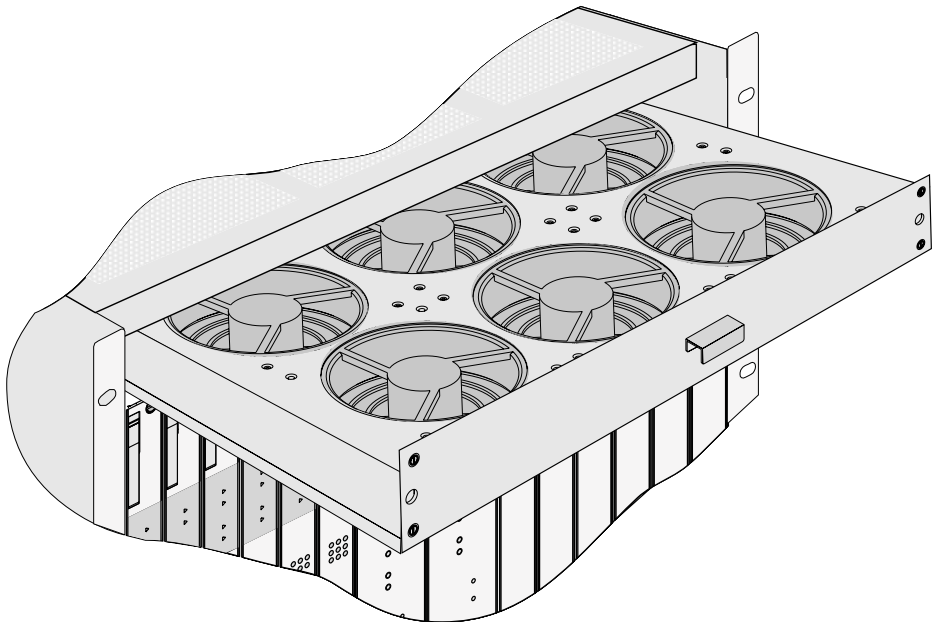

Figure 7-6 Fan tray in ERX-1400 series

Removing the Fan Tray

To remove the fan tray:



Caution: Do not use the fan tray handle to carry the fan tray assembly. Use the handle only to pull the tray out of the chassis.

- 1 Place a flathead screwdriver in the groove where the top bezel meets the chassis on the top of the system, and lever the top bezel off the front of the system.
- 2 With a flathead screwdriver, loosen the four captive screws located at the corners of the fan tray.



Warning: Do not place your fingers near the fans when removing the fan tray. The blades may still be moving.

- 3 Pull the fan tray halfway out of the shelf.



Warning: Slowly slide the fan tray out of the chassis. The tray has no stops to prevent it from sliding all the way out.

- 4 Pull the tray out of the chassis.

Installing the Fan Tray

To install the fan tray:



Caution: Do not use the fan tray handle to carry the fan tray assembly. Use the handle only to push the tray into the chassis.

- 1 Hold the tray vertically so that the captive screws point towards you and you can read text on the labels.
- 2 Place the bottom corners of the tray housing in the plastic shelf guides of the fan tray compartment; push toward the back of the chassis halfway, and stop.
- 3 Push the fan tray toward the back of the shelf until it stops.

There is an electrical connector on the back of the fan tray that pairs with an electrical connector at the back of the shelf.

- 4 With a flathead screwdriver, tighten the captive screws.

Alternate between screws when tightening them to ensure that the electrical connectors at the back of the tray fit tightly.

- 5 Push the top bezel back on the front of the system.

ERX-700 Series

Figure 7-7 shows the location of the fan tray in the ERX-700 series.

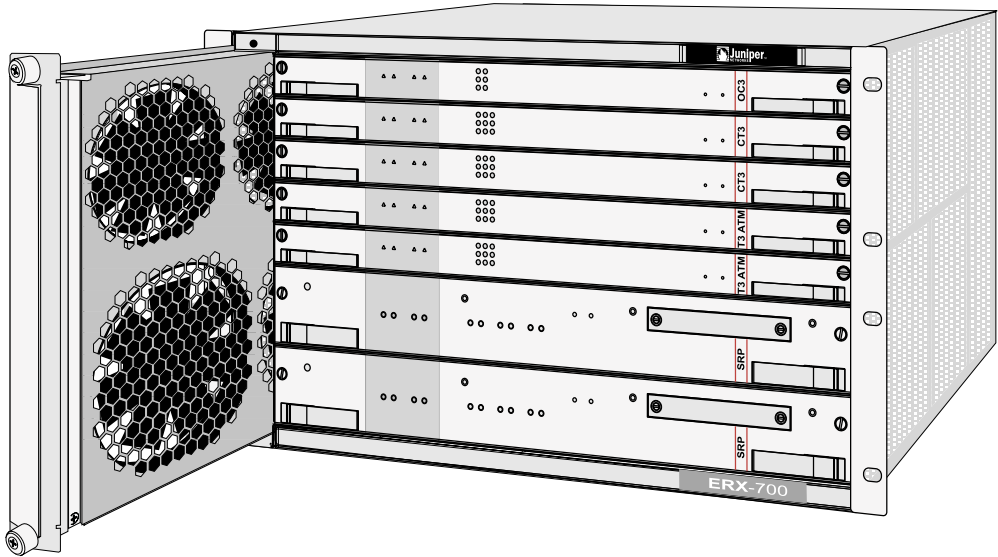

Figure 7-7 Location of fan tray on the front of the ERX-700 series

Removing the Fan Tray



Caution: Do not use the fan tray handle to carry the fan tray assembly. Use the handle only to pull the tray out of the chassis.

To remove the fan tray:

- 1 Using a Philips screwdriver, loosen the two captive screws located at top and bottom of the fan tray.



Warning: Do not place your fingers near the fans when removing the fan tray. The blades may still be moving.

- 2 Pull the fan tray halfway out of the shelf.



Warning: Slowly slide the fan tray out of the chassis. The tray has no stops to prevent it from sliding all the way out.

- 3 Pull the tray out of the chassis.

Installing the Fan Tray



Caution: Do not use the fan tray handle to carry the fan tray assembly. Use the handle only to push the into the chassis.

To install the fan tray:

- 1 Hold the tray vertically so that the captive screws point towards you and you can read text on the labels.
- 2 Place the bottom corners of the tray housing in the plastic shelf guides of the fan tray compartment; push toward the back of the chassis halfway, and stop.
- 3 Push the fan tray toward the back of the shelf until it stops.
There is an electrical connector on the back of the fan tray that pairs with an electrical connector at the back of the shelf.
- 4 With a Philips screwdriver, tighten the captive screws on the fan tray.
Alternate between screws when tightening them to ensure that the electrical connectors at the back of the tray fit tightly.

