



DX Application Acceleration Platform Quick Start

Release 5.3
22 June 2007
Part No.
093-1816-001
Revision 3

Welcome to the Juniper DX 3200 and 3600 series data center application acceleration platforms. This quick start describes how to install a DX device, perform the initial configuration, and access the device over the network.

For more information, see the DX Application Acceleration Platform documentation on the DXOS Product Documentation CD.

This quick start contains the following topics:

- “Before You Begin” on page 2
- “Installing and Connecting Power” on page 2
 - “Setting Up the Chassis” on page 3
 - “Connecting the Power” on page 4
 - “Configuring Network Settings” on page 5
 - “Connecting the Network Cables” on page 6
- “Safety Warnings Summary” on page 7
- “Where to Go Next” on page 7

Before You Begin

Perform the following tasks before starting the installation of your DX platform:

- Verify that the package contains one DX platform, power cable(s), a null modem cable, and a documentation CD.
- Ensure sufficient power is available. Supply circuits should be protected by a maximum 20 A circuit breaker.
- Ensure a minimum of 6 inches clearance in the front and back of the chassis.
- View the latest DX release notes online for the latest product notes and software version available.
- On the LAN switch that directs traffic to your Web servers, identify a 1 Gbps Ethernet port. The DX 36xx series platforms are available with fiber-optic interfaces.

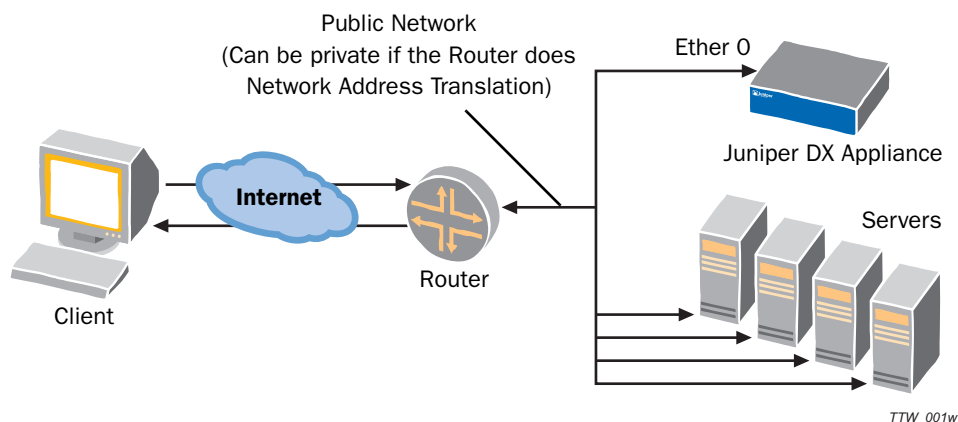

Installing and Connecting Power

To install a DX Application Acceleration Platform, perform the following tasks:

- “Setting Up the Chassis” on page 3
- “Connecting the Power” on page 4
- “Configuring Network Settings” on page 5
- “Connecting the Network Cables” on page 6

Setting Up the Chassis

To set up your chassis:

1. Attach an electrostatic discharge (ESD) grounding strap to your bare wrist, and connect the strap to an outside ESD point.
2. Install the DX platform either on the desktop or in a standard rack.

For desktop installation, simply place the chassis on a flat surface.

For rack mount installation, you can install the DX platform in one of the following ways:

- a. In a two-post rack using the rack ears on the platform itself (front mount) or by attaching the supplied mid-mount brackets (front panel forward, mid-mount) to the device.
- b. In a four-post rack using the rack ears on the platform (front mount) or by attaching the supplied rear-mount rails (front and rear mount) to the device.

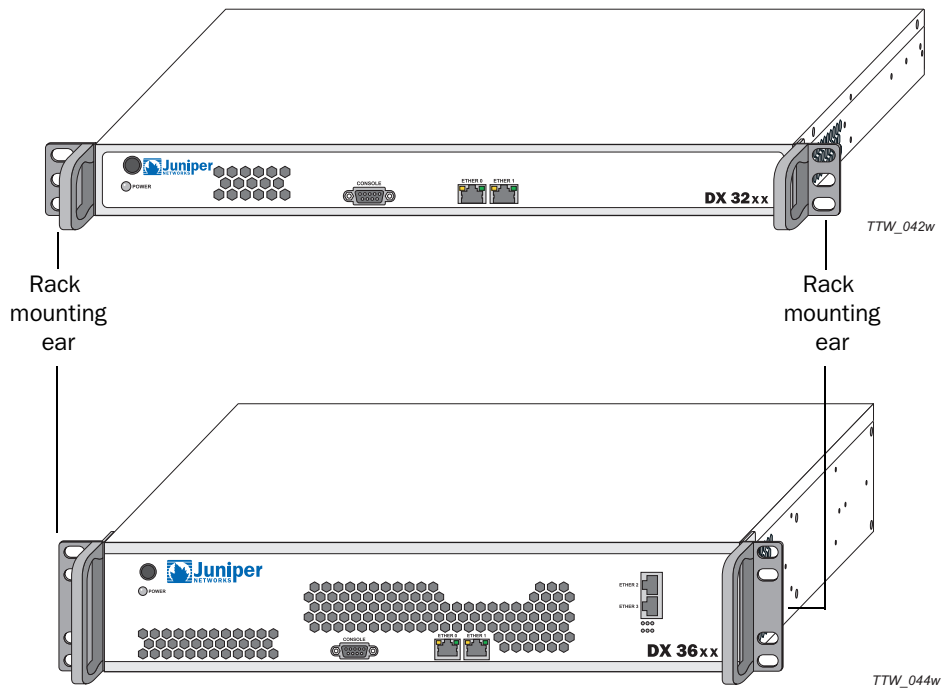

Connecting the Power

To apply power to the *DX 32xx* devices:

1. Connect the power cord from the back of the chassis to an AC power source.

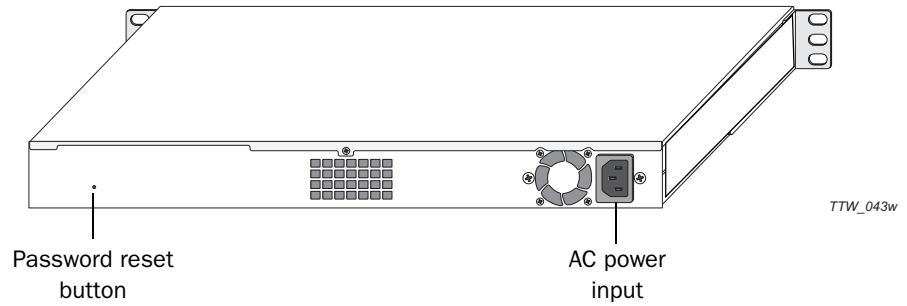

2. Press the On/Off power button on the front of the chassis to start the boot process.

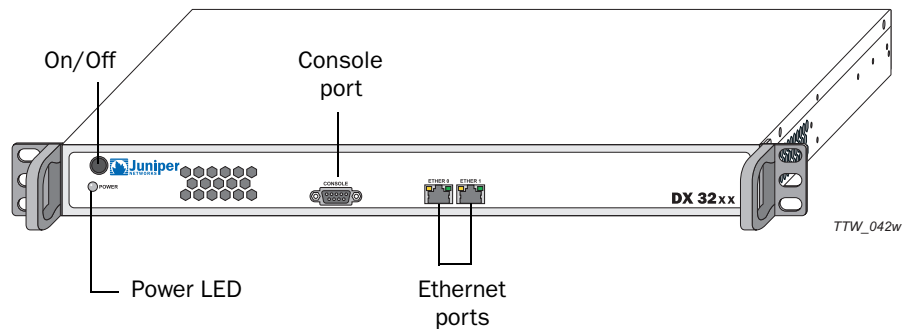

To apply power to the *DX 36xx* devices:

1. Connect a power cord from either power supply on the back of the chassis to an AC power source.

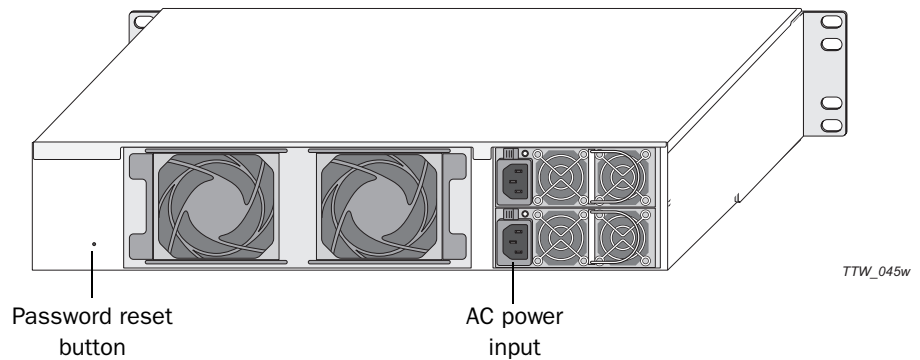

2. Press the power button on the front of the chassis to start the boot process.

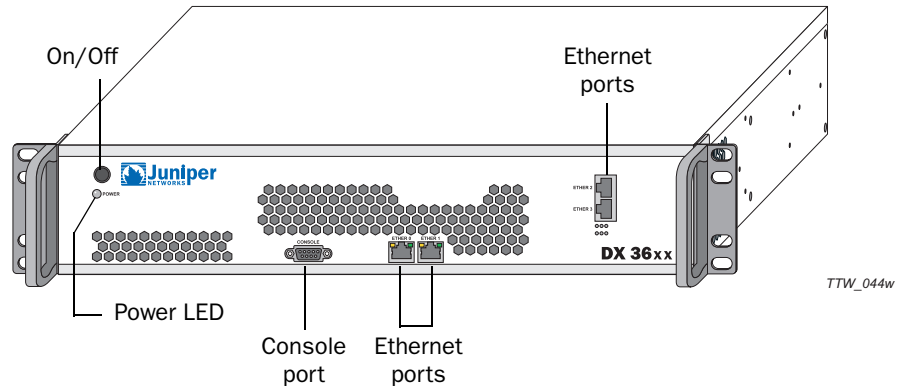

The power supply emits a continuous beep if the second power supply has no power. Connect the second power cord to stop the beep.

The boot process may take up to two minutes; allow several minutes before proceeding.

Configuring Network Settings

To configure the basic network settings:

1. Connect an ANSI compatible terminal to the console port on the front of the chassis.
2. Use a terminal emulation program (such as HyperTerminal) to log in to the CLI.
 - a. Start the terminal emulation program, and choose to connect via the serial port using the following settings:
 - Baud Rate: **9600**, Data Bits: **8**, Parity: **NONE**, Stop Bits: **1**,
 - Flow Control: **NONE**, Smooth-Scroll: **DISABLED**
 - b. Enter **admin** for the user name and password.
 - c. Read the license agreement, type **yes** and press **Enter** to proceed.
3. Enter the information requested by the various prompts, and press **Enter**:

Required Information

- IP address of the Ether0 port on the DX device (such as “172.17.0.2”).
- Subnet mask for the IP address (such as “255.255.0.0”).
- Fully-qualified host name for the DX device (such as “dx.juniper.net”).
- IP address of the gateway used for the default route (such as “172.17.0.1”).

- DNS domain (the “domain suffix”) where the DX device is installed (such as “juniper.net”).
- IP address of the primary DNS server.

Optional Information (press Enter to define later)

- Enter **y** or **n** to enable or disable Web access to the DX device. If you enable the Web interface, you are prompted for the port number. To use the Web interface, enter the Ether0 address and the specified port in your browser (such as “http://192.168.4.76:8090”).
- For the last two prompts, enter **y** or **n** to enable or disable Secure Shell (SSH) and Telnet access to the DX device.

After the last prompt, you should see the following:

```
Writing configuration.
Done.
hostname%
```

The command line prompt is the first part of the DX domain name followed by a percent (%) sign.

4. For security reasons, enter the following command to change the default password for the “admin” account:

```
hostname% set password
```



NOTE: If you forget the password, you can press and hold the password reset button on the back panel for five seconds to restore the default value.

Connecting the Network Cables

To connect network cables to the DX 32xx devices:

- Connect an Ethernet cable from one of the Ethernet ports on the DX device to a Gigabit switch port set to 1000BaseTX.
- DO NOT use autoselect on either port.

To connect network cables to the DX 36xx devices:

- Connect an Ethernet cable from one of the Ethernet ports on the DX device to either a copper or fiber Gigabit switch port set to 1000BaseTX.
- Use autoselect ONLY for fiber-optic ports.

Safety Warnings Summary



NOTE: This is a summary of safety warnings. For a complete list of warnings, including translations, see the *Juniper Product Safety Guide* on the *DXOS Product Documentation CD*.

- Perform only the procedures described in this quick start or the *Installation and Administration Guide for DXOS*.
- Manually rack mounting a DX device requires one person to lift the device and a second person to install the mounting screws. To prevent injury, keep your back straight and lift with your legs, not your back.
- When mounting a DX device in a partially filled rack, load the rack from the bottom to the top, with the heaviest component at the bottom of the rack.
- If the rack is provided with stabilizing devices, install the stabilizers before mounting or servicing devices in the rack.
- The power supplies and fans are field-serviceable only on the DX 36xx devices. Opening the chassis of any DX device voids the product warranty.
- Do not work on the system or connect or disconnect cables during electrical storms.
- Before working on equipment that is connected to power lines, remove jewelry, including rings, necklaces, and watches. Metal objects heat up when connected to power and ground and can cause serious burns or become welded to the terminals.
- Failure to observe these safety warnings can result in serious physical injury.

Where to Go Next

Initial configuration is complete and you are now ready to configure advanced settings for the device. Refer to the *Installation and Administration Guide for DXOS* and the *Command Line Reference Guide for DXOS*, which are provided on the *DXOS Product Documentation CD*.

Visit the Juniper Networks online Customer Support Center (CSC) at <http://www.juniper.net/support> for updated product documentation, the latest software version, to register your product, to license add-on product features, or to open a Customer Care case. If you need additional assistance, please contact Customer Care at 1-800-638-8296 (United States) or +1-408-936-1572 (outside the United States).

Copyright © 2006-2007, Juniper Networks, Inc. All rights reserved.

Juniper Networks, the Juniper Networks logo, NetScreen, and ScreenOS are registered trademarks of Juniper Networks, Inc. in the United States and other countries. JUNOS and JUNOSe are trademarks of Juniper Networks, Inc. All other trademarks, service marks, registered trademarks, or registered service marks are the property of their respective owners.

Juniper Networks assumes no responsibility for any inaccuracies in this document. Juniper Networks reserves the right to change, modify, transfer, or otherwise revise this publication without notice.

Products made or sold by Juniper Networks or components thereof might be covered by one or more of the following patents that are owned by or licensed to Juniper Networks: U.S. Patent Nos. 5,473,599, 5,905,725, 5,909,440, 6,192,051, 6,333,650, 6,359,479, 6,406,312, 6,429,706, 6,459,579, 6,493,347, 6,538,518, 6,538,899, 6,552,918, 6,567,902, 6,578,186, and 6,590,785.