

Removing Components from the MX960 Chassis Before Installing It Without a Lift

If you cannot use a mechanical lift to install the router (the preferred method), you can install it manually. Before installing the router manually, you must first remove components from the chassis, and reinstall the components the router is installed in the rack. With components removed, the chassis weighs approximately 150 lb (68.04 kg).

1. Removing the Power Supplies Before Installing an MX960 Router Without a Lift on page 1
2. Removing the Standard Cable Manager Before Installing an MX960 Router Without a Lift on page 2
3. Removing the Fan Trays Before Installing an MX960 Router Without a Lift on page 3
4. Removing the SCBs Before Installing an MX960 Router Without a Lift on page 5
5. Removing the DPCs Before Installing an MX960 Router Without a Lift on page 6
6. Removing the FPCs Before Installing the MX960 Router Without a Lift on page 7

Removing the Power Supplies Before Installing an MX960 Router Without a Lift

Remove the leftmost power supply first and then work your way to the right. To remove the AC or DC power supplies for each power supply (see Figure 1):

1. Attach an electrostatic discharge (ESD) grounding strap to your bare wrist, and connect the strap to one of the ESD points on the chassis. For more information about ESD, see Preventing Electrostatic Discharge Damage to an M Series, MX Series, or T Series Router.
2. On an AC-powered router, move the AC input switch in the chassis above each power supply to the off (O) position. On a DC-powered router, move the DC circuit breaker on each power supply faceplate to the off (O) position.

We recommend this even though the power supplies are not connected to power sources.

3. While grasping the handle on the power supply faceplate with one hand, use your other hand to pull the spring-loaded locking pin in the release lever away from the chassis and turn the release lever counterclockwise until it stops.
4. Let go of the locking pin in the release lever. Ensure that the pin is seated inside the corresponding hole in the chassis.
5. Pull the power supply straight out of the chassis.



WARNING: Do not touch the power connector on the top of the power supply. It can contain dangerous voltages.

Figure 1: Removing a Power Supply Before Installing the MX960 Router

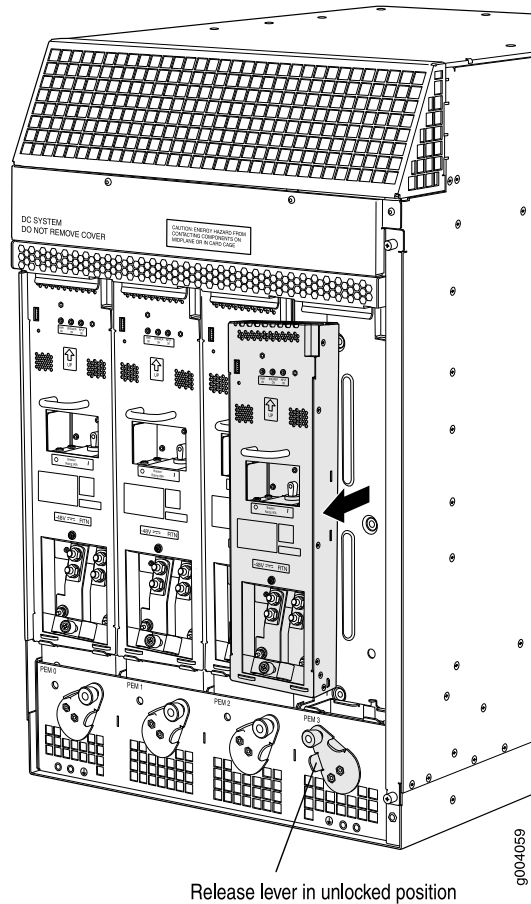

Removing the Standard Cable Manager Before Installing an MX960 Router Without a Lift

To remove the standard cable manager (see Figure 2):

1. Attach an electrostatic discharge (ESD) grounding strap to your bare wrist, and connect the strap to one of the ESD points on the chassis. For more information about ESD, see Preventing Electrostatic Discharge Damage to an M Series, MX Series, or T Series Router.
2. Using a 7/16-in. (11 mm) nut driver, unscrew the nuts on the corners of the standard cable manager.
3. Grasp the bottom of the standard cable manager and pull it straight out from the studs on the front of the chassis.

Figure 2: Removing the Standard Cable Manager

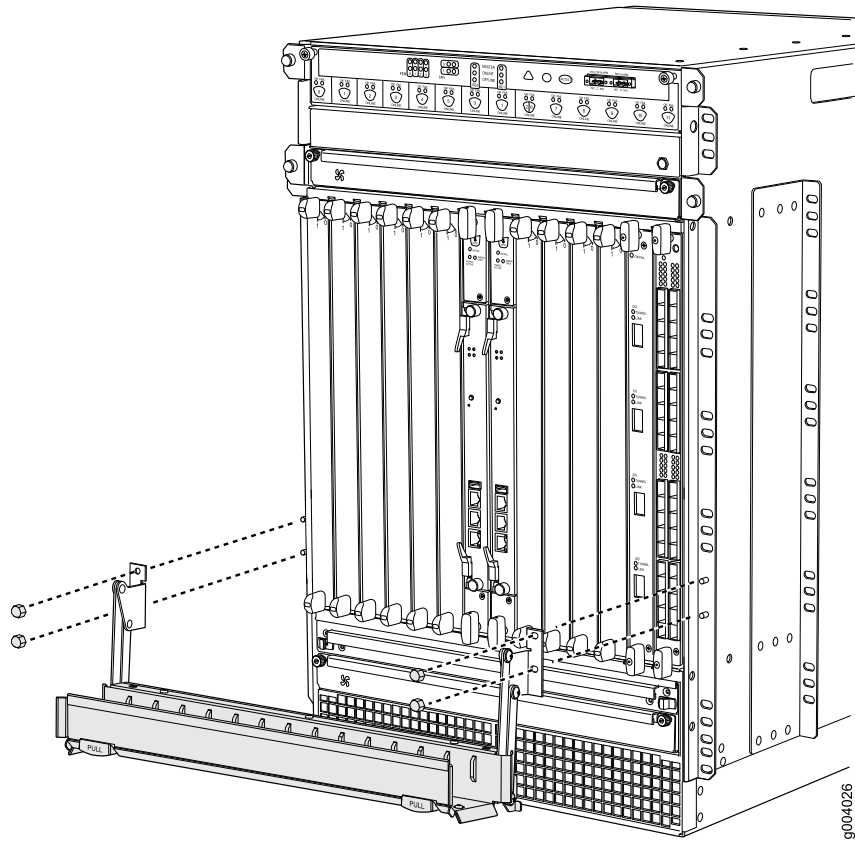

Removing the Fan Trays Before Installing an MX960 Router Without a Lift

To remove the upper or lower fan tray (see Figure 3 and Figure 4, which illustrate the upper and lower fan trays):

1. Attach an electrostatic discharge (ESD) grounding strap to your bare wrist, and connect the strap to one of the ESD points on the chassis. For more information about ESD, see Preventing Electrostatic Discharge Damage to an M Series, MX Series, or T Series Router.
2. Loosen the captive screw on each side of the fan tray faceplate.
3. Grasp both sides of the fan tray and pull it out approximately 1 to 3 inches.
4. Press on the two latches located on the inside of the fan tray to release the fan tray from the chassis.
5. Place one hand under the fan tray to support it and pull the fan tray completely out of the chassis.

Figure 3: Removing an Upper Fan Tray

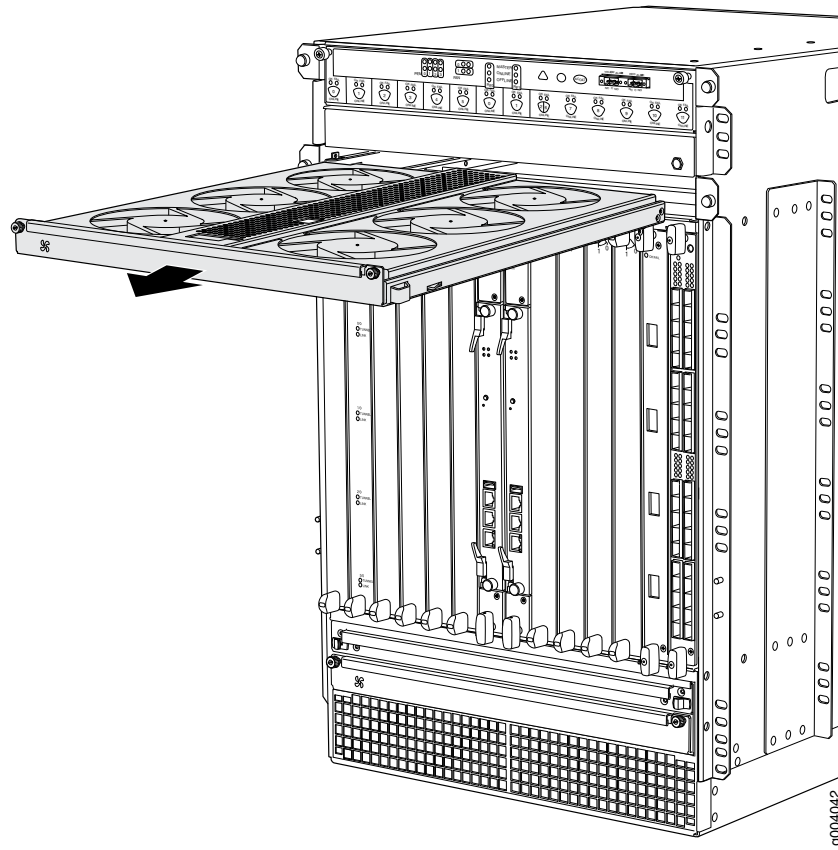
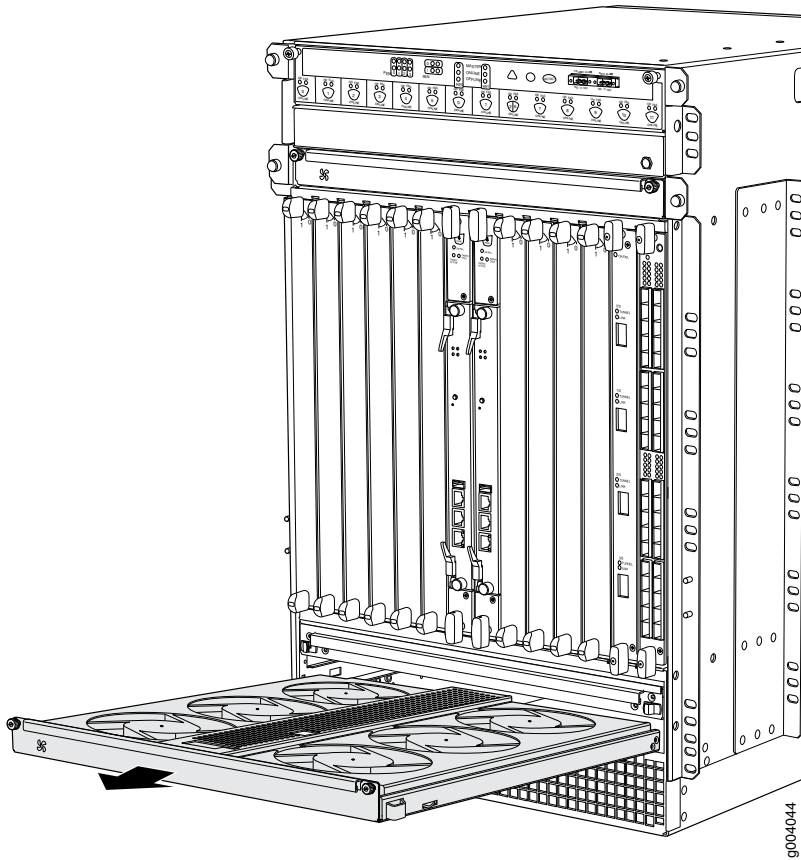

Figure 4: Removing a Lower Fan Tray



Removing the SCBs Before Installing an MX960 Router Without a Lift

To remove the SCBs (see Figure 5):

1. Place an electrostatic bag or antistatic mat on a flat, stable surface.
2. Attach an electrostatic discharge (ESD) grounding strap to your bare wrist, and connect the strap to an approved site ESD grounding point. See the instructions for your site.
3. Rotate the ejector handles simultaneously counterclockwise to unseat the SCB.
4. Grasp the ejector handles, and slide the SCB about halfway out of the chassis.
5. Place one hand underneath the SCB to support it, and slide it completely out of the chassis. Place it on the antistatic mat.



CAUTION: Do not stack hardware components on one another after you remove them. Place each component on an antistatic mat resting on a stable, flat surface.

6. Repeat the procedure for each SCB.

Figure 5: Removing an SCB

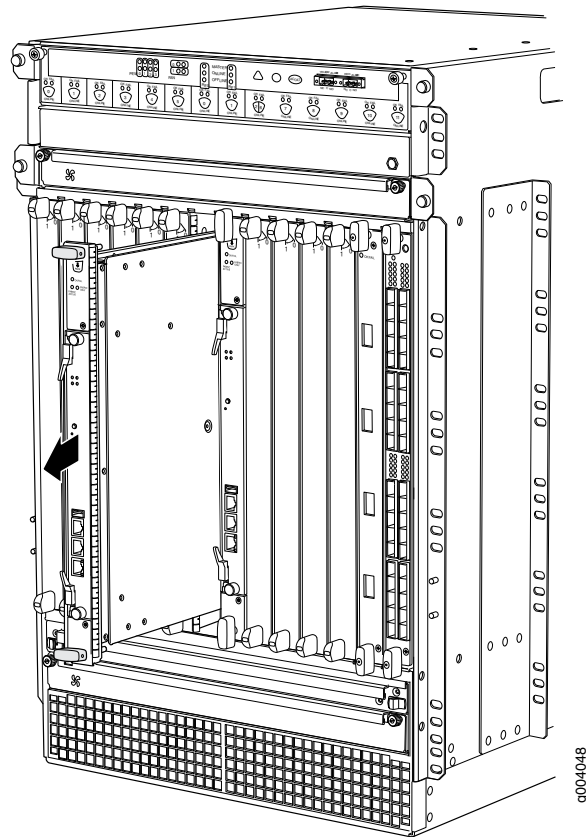

Removing the DPCs Before Installing an MX960 Router Without a Lift

To remove a DPC (see Figure 6):

1. Have ready an antistatic mat for the DPC. Also have ready rubber safety caps for each DPC using an optical interface on the DPC that you are removing.
2. Attach an electrostatic discharge (ESD) grounding strap to your bare wrist, and connect the strap to an approved site ESD grounding point. See the instructions for your site.
3. Simultaneously turn both the ejector handles counterclockwise to unseat the DPC.
4. Grasp the handles, and slide the DPC straight out of the card cage halfway.
5. Place one hand around the front of the DPC and the other hand under it to support it. Slide the DPC completely out of the chassis, and place it on the antistatic mat or in the electrostatic bag.



CAUTION: The weight of the DPC is concentrated in the back end. Be prepared to accept the full weight—up to 13.1 lb (5.9 kg)—as you slide the DPC out of the chassis.

When the DPC is out of the chassis, do not hold it by the ejector handles, bus bars, or edge connectors. They cannot support its weight.

Do not stack DPC on top of one another after removal. Place each one individually in an electrostatic bag or on its own antistatic mat on a flat, stable surface.

Figure 6: Removing a DPC

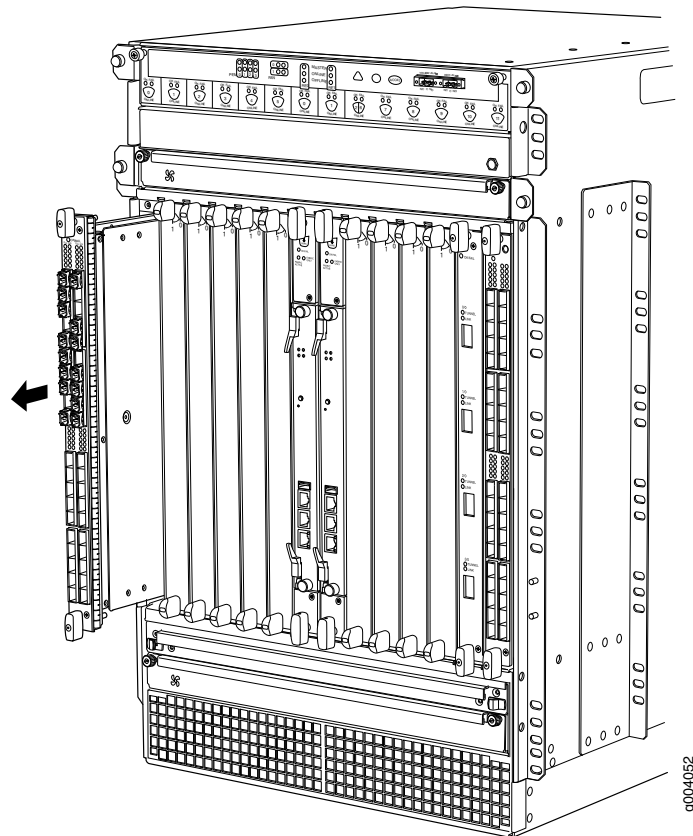

Removing the FPCs Before Installing the MX960 Router Without a Lift

To remove an FPC (see Figure 7):

1. Have ready an antistatic mat for the FPC. Also have ready rubber safety caps for each PIC using an optical interface on the PIC that you are removing.
2. Attach an electrostatic discharge (ESD) grounding strap to your bare wrist, and connect the strap to one of the ESD points on the chassis. For more information about ESD, see Preventing Electrostatic Discharge Damage to an M Series, MX Series, or T Series Router.
3. Simultaneously turn both the ejector handles counterclockwise to unseat the FPC.

4. Grasp the handles and slide the FPC straight out of the card cage halfway.
5. Place one hand around the front of the FPC and the other hand under it to support it. Slide the FPC completely out of the chassis, and place it on the antistatic mat or in the electrostatic bag.



CAUTION: The weight of the FPC is concentrated in the back end. Be prepared to accept the full weight—up to 18 lb (8.2 kg)—as you slide the FPC out of the chassis.

When the FPC is out of the chassis, do not hold it by the ejector handles, bus bars, or edge connectors. They cannot support its weight.

Figure 7: Removing an FPC

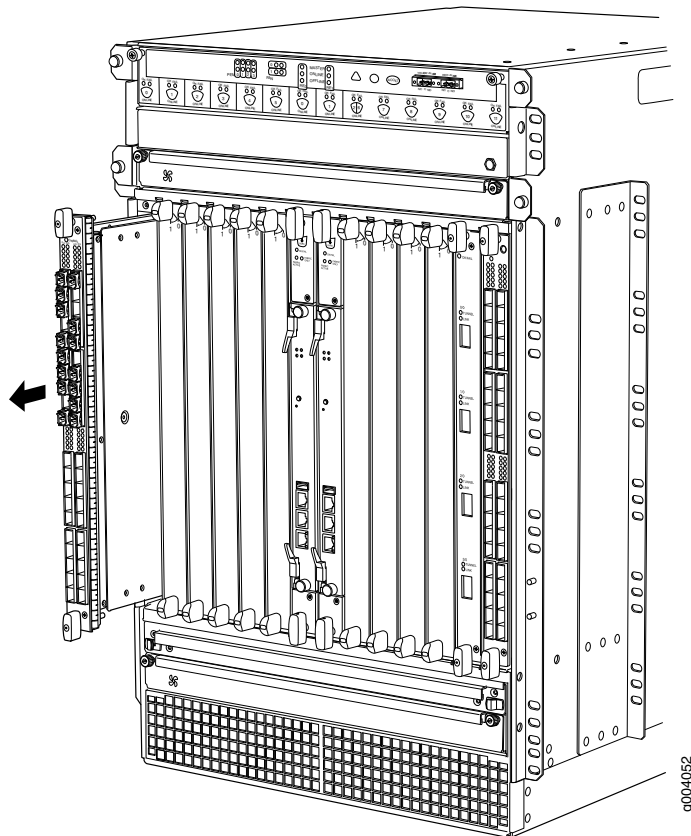

- Related Topics**
- Preventing Electrostatic Discharge Damage to an M Series, MX Series, or T Series Router
 - Reinstalling Components in the MX960 Chassis After Installing It Without a Lift

- Tools and Parts Required to Replace Components from an M Series, MX Series, or T Series Router
- Installing the MX960 Chassis in the Rack Manually

Published: 2010-01-24