

SRX5600 Services Gateway

Getting Started Guide

February 2011
Part Number: 530-038206
Revision 01

This document describes how to install the SRX5600 Services Gateway.

Contents

About This Guide	3
Step 1: Prepare the Site for SRX5600 Services Gateway Installation	4
Rack Mounting Requirements	4
Tools Required to Unpack and Prepare the SRX5600 Services Gateway for Installation	5
Step 2: Install the Mounting Hardware in a Four-Post Rack or Cabinet or an Open-Frame Rack	5
Step 3: Install the Services Gateway	7
Remove Components	8
Install the Services Gateway Using a Lift	9
Install the Services Gateway Without a Mechanical Lift	10
Reinstall Components	11
Step 4: Connect the Grounding Cable	12
Step 5: Connect External Devices and IOC Cables	13
Connect to a Network for Out-of-Band Management	13
Connect a Management Console	13
Connect the IOC Cables	13
Step 6: Connect Power Cables	14
Connect Power to an AC-Powered Services Gateway	14
Connect Power to a DC-Powered Services Gateway	15
Step 7: Perform the Initial Software Configuration	17
Enter Configuration Mode	17
Configure User Accounts and Passwords	18
Configure System Attributes	18
Commit the Configuration	19
Safety Warnings	21

SRX5600 Services Gateway Compliance Statements for EMC	
Requirements	23
Canada	23
European Community	23
Japan	23
United States	24
SRX Series Documentation and Release Notes	24
Requesting Technical Support	24
Revision History	25

About This Guide

This guide contains information that you need to install and configure the SRX5600 Services Gateway quickly. For complete installation instructions see the *SRX5600 Services Gateway Hardware Guide* at <http://www.juniper.net/techpubs/>.



WARNING: This guide contains a summary of safety warnings in “Safety Warnings” on page 21. For a complete list of warnings for this device, including translations, see the *SRX5600 Services Gateway Hardware Guide* at <http://www.juniper.net/techpubs/>.

The SRX5600 Services Gateway is a high-performance, highly scalable, carrier-class security device with multiprocessor architecture. The services gateway has a capacity of up to 60 gigabits per second (Gbps), full duplex. The services gateway is eight rack units (RU) tall. Five services gateways can be stacked in a single floor-to-ceiling rack, for increased port density per unit of floor space. The services gateway provides eight slots that can be populated with up to six Services Processing Cards (SPCs) and I/O cards (IOCs) and two Switch Control Boards (SCBs) in nonredundant fabric configurations.

By installing various combinations of IOCs and SPCs, you can tailor both the number of gigabit ports and the maximum security processing capacity to suit your network. Table 1 on page 3 describes the minimum system configuration for the SRX5600 Services Gateway.

Table 1: Minimum System Configuraton

Component	Minimum
SPC	1
IOC	1
SCB	1
Routing Engine	1

When fully populated, the SRX5600 Services Gateway provides up to 200 Gigabit Ethernet or up to twenty 10-Gigabit Ethernet ports. Two types of IOC interface cards are available, each consisting of four Packet Forwarding Engines and enabling a throughput of 10 Gbps. You can install any combination of IOC types in the services gateway.

The SRX5600 Services Gateway provides redundancy and resiliency. The hardware system is fully redundant, including power supplies and SCBs.

The services gateway is shipped in a cardboard box strapped securely to a wooden pallet. Plastic straps secure the top and bottom in place. The services gateway chassis is bolted to this pallet. A printed copy of this document and a cardboard accessory box are also included in the shipping container.

Step 1: Prepare the Site for SRX5600 Services Gateway Installation

- Rack Mounting Requirements on page 4
- Tools Required to Unpack and Prepare the SRX5600 Services Gateway for Installation on page 5

Rack Mounting Requirements

- You can install the services gateway in a four-post rack or cabinet or an open-frame rack.
- The rack rails must be spaced widely enough to accommodate the services gateway chassis's external dimensions: 14.0 in. (35.6 cm) high, 24.5 in. (62.2 cm) deep, and 17.45 in. (44.3 cm) wide. The outer edges of the mounting brackets extend the width to 19 in. (48.3 cm). See Figure 1 on page 4.

Figure 1: Rack Clearance and Chassis Dimensions

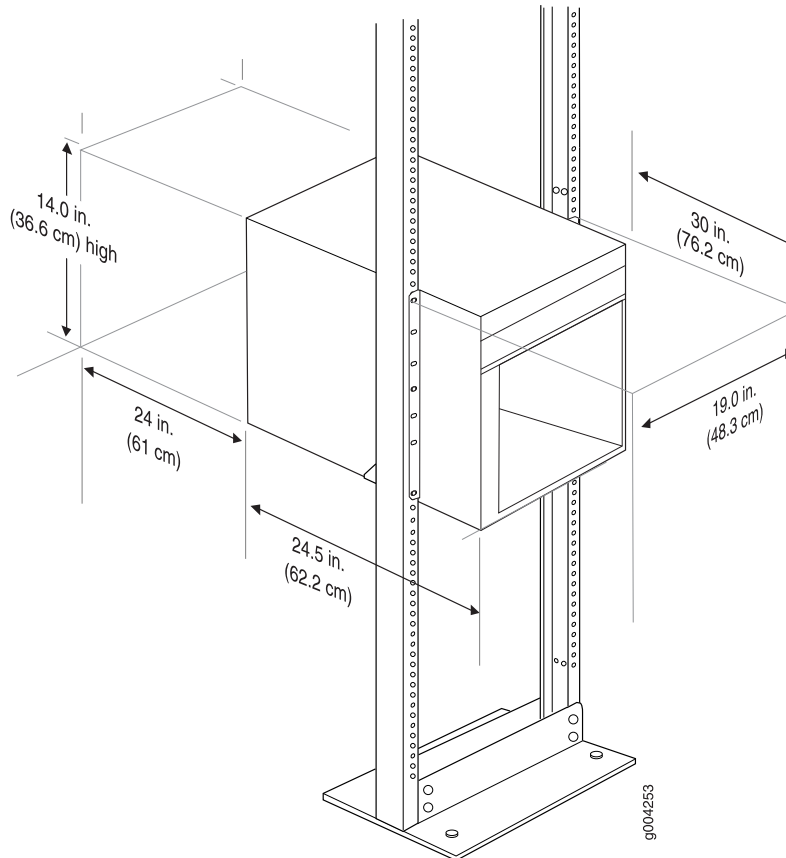

- The rack must be strong enough to support the weight of the fully configured services gateway, up to 163.5 lb (74.2 kg). If you stack five fully configured services gateways in one rack, it must be capable of supporting about 818 lb (371.0 kg).
- For service personnel to remove and install hardware components, there must be adequate space at the front and back of the services gateway. Allow at least

30 in. (76.2 cm) in front of the services gateway and 24 in. (61 cm) behind the services gateway.

- The rack or cabinet must have an adequate supply of cooling air.
- Ensure that the cabinet allows the chassis hot exhaust air to exit the cabinet without recirculating into the services gateway.
- The services gateway must be installed into a rack that is secured to the building structure.
- The services gateway should be mounted at the bottom of the rack if it is the only unit in the rack.
- When mounting the services gateway in a partially filled rack, load the rack from the bottom to the top, with the heaviest component at the bottom of the rack.

Tools Required to Unpack and Prepare the SRX5600 Services Gateway for Installation

To unpack the services gateway and prepare for installation, you need the following tools:

- A mechanical lift—recommended
- Phillips (+) screwdrivers, numbers 1 and 2
- 2.5-mm flat-blade (–) screwdriver
- 7/16-in. torque-controlled driver or socket wrench
- 1/2-in. or 13-mm open-end or socket wrench to remove bracket bolts from the shipping pallet
- Electrostatic discharge wrist strap
- Antistatic mat

Proceed to “Step 2: Install the Mounting Hardware in a Four-Post Rack or Cabinet or an Open-Frame Rack” on page 5.

Step 2: Install the Mounting Hardware in a Four-Post Rack or Cabinet or an Open-Frame Rack

To install the mounting shelf on the front rails of a four-post rack or cabinet, or on the rails of an open-frame rack:

1. If needed, install cage nuts in the holes specified in Table 2 on page 6.
2. On the back of each rack rail, partially insert a mounting screw into the lowest hole specified in Table 2 on page 6.
3. Install the mounting shelf on the back of the rack rails. Rest the bottom slot of each flange on a mounting screw.
4. Partially insert screws into the open holes in each flange of the mounting shelf (see Figure 2 on page 6 or Figure 3 on page 7).
5. Tighten all the screws completely.

Table 2: Mounting Shelf Hole Locations

Hole (Starting from U Division)	Distance Above U Division	
4	2.00 in. (5.1 cm)	1.14 U
3	1.51 in. (3.8 cm)	0.86 U
2	0.88 in. (2.2 cm)	0.50 U
1	0.25 in. (0.6 cm)	0.14 U

Figure 2: Mounting Hardware for a Four-Post Rack or Cabinet

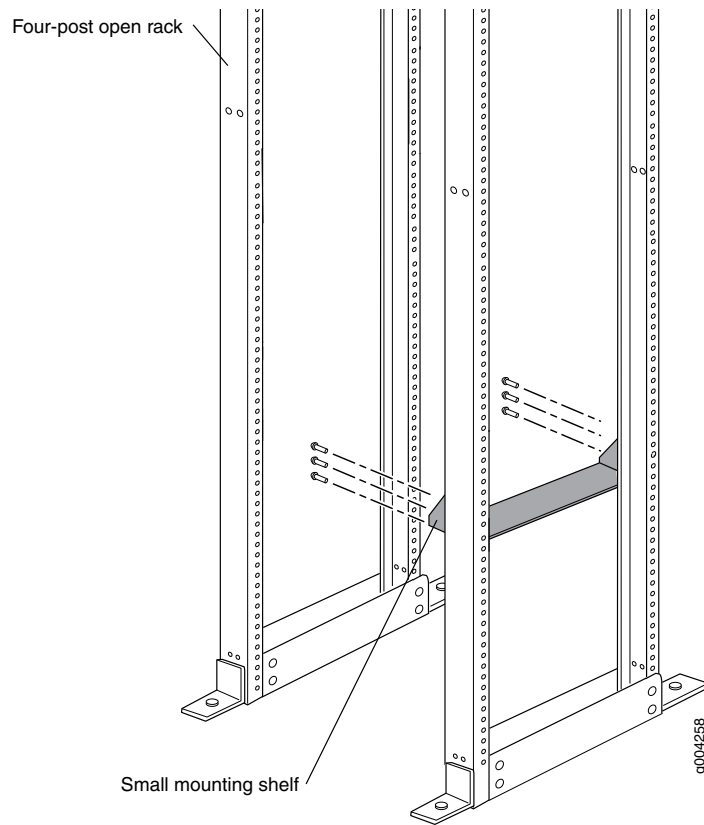
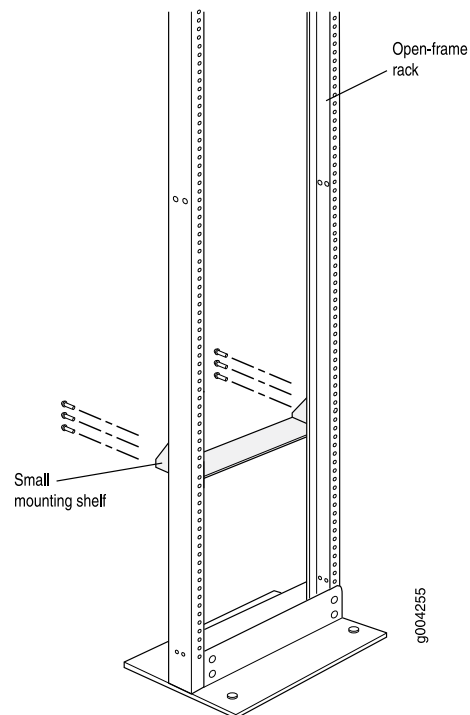

Figure 3: Mounting Hardware for an Open-Frame Rack



Proceed to “Step 3: Install the Services Gateway” on page 7.

Step 3: Install the Services Gateway

Because of the services gateway’s size and weight, you must remove all components, as shown in Figure 4 on page 8 and Figure 5 on page 8, before installing the services gateway. We also recommend using a mechanical lift to install the services gateway.

- Remove Components on page 8
- Install the Services Gateway Using a Lift on page 9
- Install the Services Gateway Without a Mechanical Lift on page 10
- Reinstall Components on page 11

Remove Components

Figure 4: Components to Remove from the Front of the Services Gateway

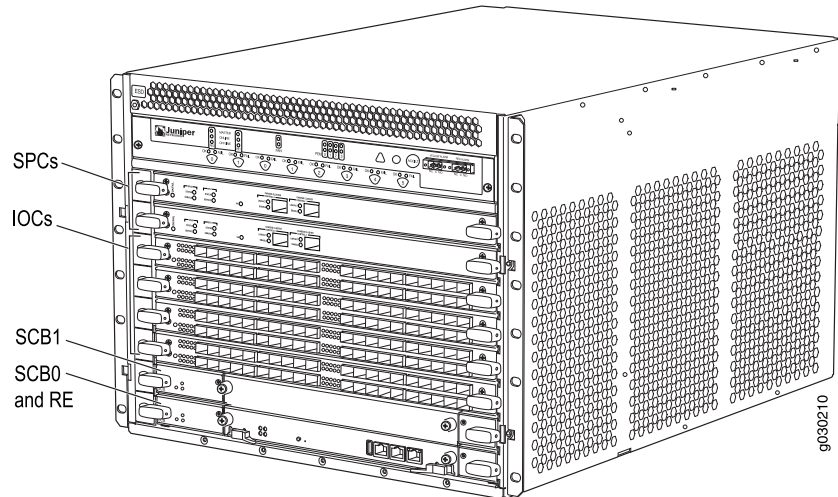
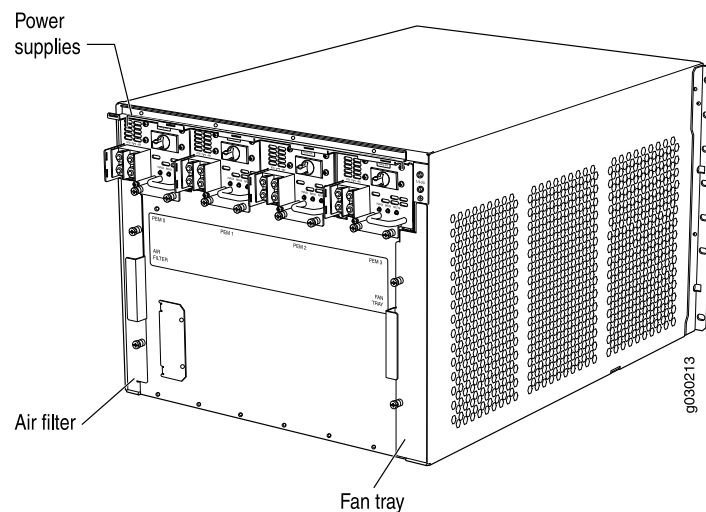

Figure 5: Components to Remove from the Rear of the Services Gateway



Before lifting the services gateway, you must remove the following components:

- Power supplies
- Switch Control Boards (SCBs)
- Routing Engine
- Air filter
- Fan tray
- I/O Cards (IOCs)
- Services Processing Cards (SPCs)

To remove the components from the services gateway:

1. Slide each component out of the chassis evenly so that it does not become stuck or damaged.
2. Label each component as you remove it so you can reinstall it in the correct location.
3. Immediately store each removed component in an electrostatic bag.
4. Do not stack removed components. Lay each one on a flat surface.



NOTE: For complete instructions on removing services gateway components, see “Install the Services Gateway Without a Mechanical Lift” in the *SRX5600 Services Gateway Hardware Guide*.

Install the Services Gateway Using a Lift

To install the services gateway using a lift:

1. Ensure that the rack is in its permanent location and is secured to the building. Ensure that the installation site allows adequate clearance for both airflow and maintenance. For details, see the *SRX5600 Services Gateway Hardware Guide*.
2. Load the services gateway onto the lift, making sure that it rests securely on the lift platform (see Figure 6 on page 9).

Figure 6: Load the Services Gateway onto the Lift

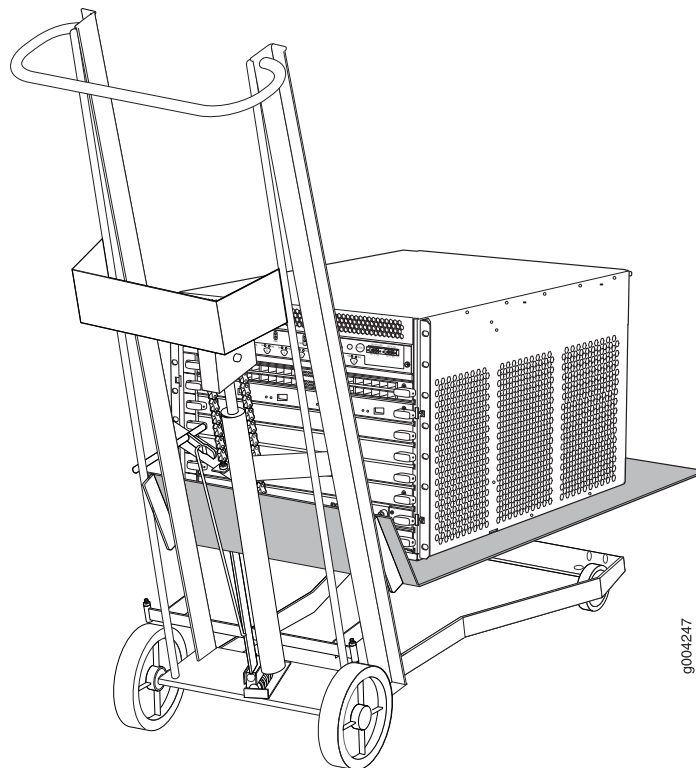

g004247

3. Using the lift, position the services gateway in front of the rack or cabinet, centering it in front of the mounting shelf.
4. Lift the chassis approximately 0.75 in. above the surface of the mounting shelf, and position it as close as possible to the shelf.
5. Carefully slide the services gateway onto the mounting shelf so that the bottom of the chassis and the mounting shelf overlap by approximately 2 inches.
6. Slide the services gateway onto the mounting shelf until the mounting brackets contact the rack rails. The shelf ensures that the holes in the mounting brackets and the front-mounting flanges of the chassis align with the holes in the rack rails.
7. Move the lift away from the rack.
8. Install a mounting screw into each of the open mounting holes aligned with the rack, starting from the bottom.
9. Visually inspect the alignment of the services gateway. If the services gateway is installed properly in the rack, all the mounting screws on one side of the rack should be aligned with the mounting screws on the opposite side and the services gateway should be level.

Install the Services Gateway Without a Mechanical Lift

Lifting the chassis and mounting it in a rack requires at least two people. The empty chassis weighs approximately 65.5 lb (29.7 kg).

1. Ensure that the rack is in its permanent location and is secured to the building.
2. Position the chassis in front of the rack or cabinet, centering it in front of the mounting shelf. Use a pallet jack if one is available.
3. With one person on each side, hold onto the bottom of the chassis and carefully lift it onto the small mounting shelf. See Figure 7 on page 11.

Figure 7: Lift the Services Gateway into the Rack

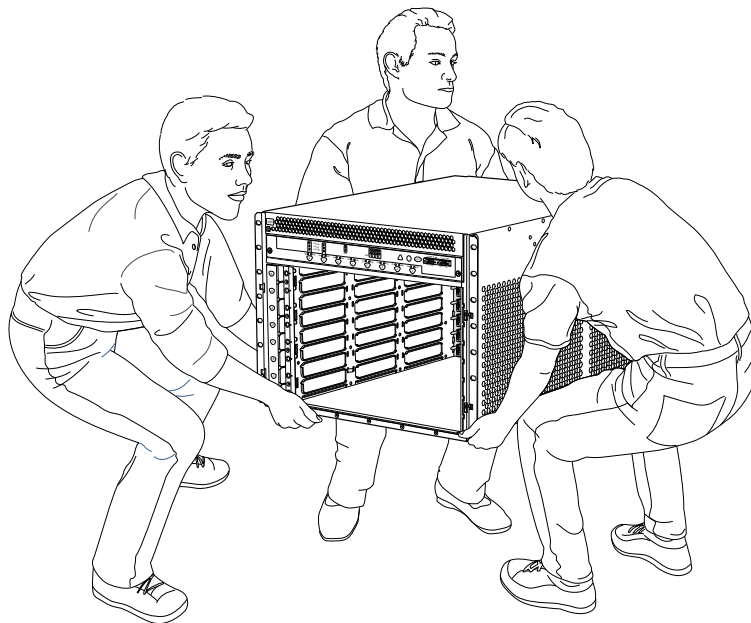

g004249

4. Slide the chassis onto the mounting shelf until the mounting brackets contact the rack rails. The shelf ensures that the holes in the mounting brackets and the front-mounting flanges of the chassis align with the holes in the rack rails.
5. To install the chassis in an open-frame rack, install a mounting screw into each of the open mounting holes aligned with the rack, starting from the bottom.
6. Visually inspect the alignment of the chassis. If the chassis is installed properly in the rack, all the mounting screws on one side of the rack should be aligned with the mounting screws on the opposite side and the chassis should be level.

Reinstall Components

1. Attach an electrostatic discharge (ESD) grounding strap to your bare wrist, and connect the strap to one of the ESD points on the chassis. For more information about ESD, see the *SRX5600 Services Gateway Hardware Guide*.
2. Slide each component into the chassis evenly so that it does not become stuck or damaged.
3. Tighten the captive screws or lock any levers for each component installed.



NOTE: Make sure that all empty slots are covered with blank panels before operating the services gateway.

Proceed to “Step 4: Connect the Grounding Cable” on page 12.

Step 4: Connect the Grounding Cable

1. Attach an electrostatic discharge (ESD) grounding strap to your bare wrist, and connect the strap to an approved site ESD grounding point. See the instructions for your site.
2. Connect the grounding cable to a proper earth ground.
3. Verify that a licensed electrician has attached the cable lug provided with the services gateway to the grounding cable.
4. Make sure that grounding surfaces are clean and brought to a bright finish before grounding connections are made.
5. Disconnect the ESD grounding strap from the site ESD grounding point, and connect it to one of the ESD points on the chassis. For more information about ESD, see the *SRX5600 Services Gateway Hardware Guide*.
6. Place the grounding cable lug over the grounding point. The grounding point is sized for UNC 1/4-20 screws and 1/4 in. split washers, which are provided in the accessory box.
7. Secure the grounding cable lug to the grounding point, first with the washers, and then with the screws as shown in Figure 8 on page 12.

Figure 8: Connecting the Grounding Cable

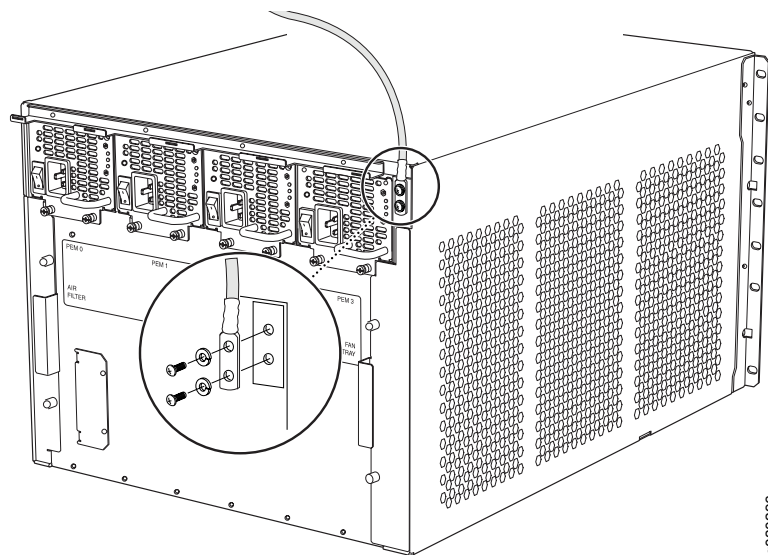

8. Verify that the grounding cabling is correct, that the grounding cable does not touch or block access to services gateway components, and that it does not drape where people could trip over it.

Proceed to “Step 5: Connect External Devices and IOC Cables” on page 13.

Step 5: Connect External Devices and IOC Cables

To connect external devices and I/O Card (IOC) cables:

- Connect to a Network for Out-of-Band Management on page 13
- Connect a Management Console on page 13
- Connect the IOC Cables on page 13

Connect to a Network for Out-of-Band Management

1. Turn off the power to the management device.
2. Plug one end of the RJ-45 Ethernet cable into the appropriate **ETHERNET** port on the services gateway Routing Engine.
3. Plug the other end of the cable into the network device.

Connect a Management Console

1. Turn off the power to the management device.
2. Plug the RJ-45 end of the serial cable into the appropriate **CONSOLE** or **AUX** port on the services gateway Routing Engine.
3. Plug the female DB-9 end into the device's serial port.

Connect the IOC Cables

1. Have ready a length of the type of cable used by the IOC. For cable specifications, see the *SRX5600 Services Gateway Hardware Guide*.
2. If the cable connector port is covered by a rubber safety plug, remove the plug.



WARNING: Do not look directly into a fiber-optic transceiver or into the ends of fiber-optic cables. Fiber-optic transceivers and fiber-optic cable connected to a transceiver emit laser light that can damage your eyes.



CAUTION: Do not leave a fiber-optic transceiver uncovered except when inserting or removing cable. The safety cap keeps the port clean and prevents accidental exposure to laser light.

3. Insert the cable connector into the cable connector port on the faceplate.

Figure 9: Connect IOC Cables

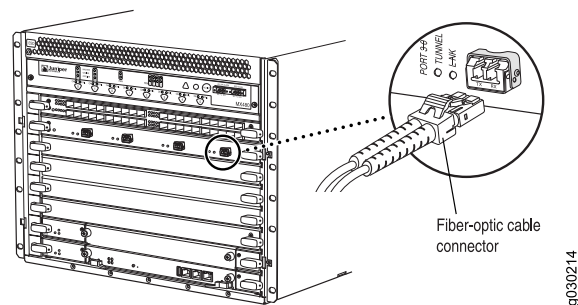

4. Arrange the cable in the cable management system to prevent it from dislodging or developing stress points. Secure the cable so that it is not supporting its own weight as it hangs to the floor. Place excess cable out of the way in a neatly coiled loop in the cable management system. Placing fasteners on the loop helps to maintain its shape.



CAUTION: Avoid bending fiber-optic cable beyond its minimum bend radius. An arc smaller than a few inches in diameter can damage the cable and cause problems that are difficult to diagnose.



CAUTION: Do not let fiber-optic cable hang free from the connector. Do not allow fastened loops of cable to dangle, which stresses the cable at the fastening point.

Proceed to “Step 6: Connect Power Cables” on page 14.

Step 6: Connect Power Cables

Depending on its configuration, the services gateway uses either AC or DC power supplies. Perform the appropriate procedures for each power supply in the services gateway.

- Connect Power to an AC-Powered Services Gateway on page 14
- Connect Power to a DC-Powered Services Gateway on page 15

Connect Power to an AC-Powered Services Gateway



NOTE: The device is not shipped with AC power cords. Make sure to order or obtain AC power cords with a plug appropriate for your geographical location.

1. Attach an electrostatic discharge (ESD) grounding strap to your bare wrist, and connect the strap to one of the ESD points on the chassis. For more information about ESD, see the *SRX5600 Services Gateway Hardware Guide*.
2. Locate the power cords you will use to connect the device to AC power. See the *SRX5600 Services Gateway Hardware Guide* for specifications.

3. For each power supply:
 - a. Move the power switch on the power supply faceplate to the **OFF** position (O).
 - b. Insert the appliance coupler end of the power cord into the appliance inlet on the power supply.
 - c. Insert the power cord plug into an external AC power source receptacle.



NOTE: Each power supply must be connected to a dedicated AC power feed and a dedicated customer site circuit breaker. We recommend using a 15-A (250-VAC), circuit breaker minimum, or as permitted by local code.

- d. Dress the power cord appropriately. Verify that the power cord does not block the air exhaust or access to services gateway components, and that it does not drape where people could trip over it.

Figure 10: Connecting AC Power to the Services Gateway

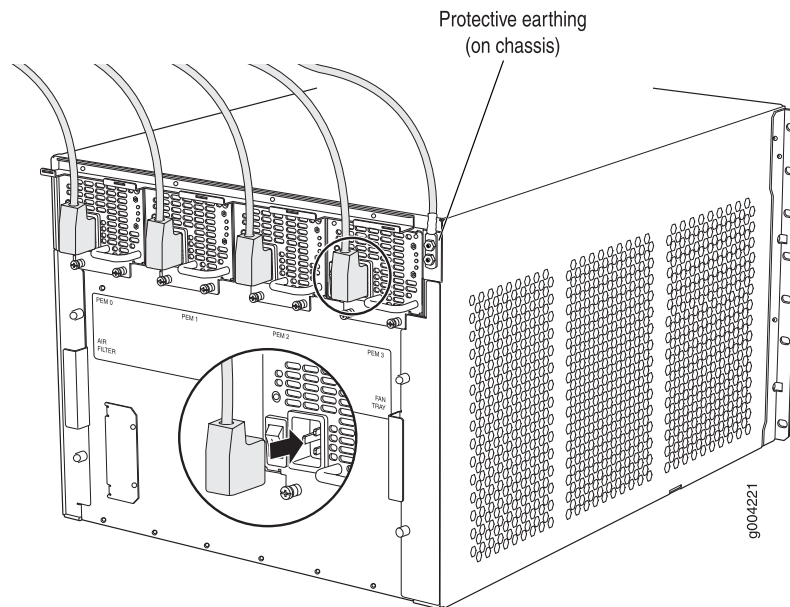

Connect Power to a DC-Powered Services Gateway

Table 3 on page 15 describes the services gateway input voltage requirements.

Table 3: DC Power System Input Voltage

Item	Specification
DC input voltage	Operating range: -40.5 to -72 VDC

1. Ensure that the voltage across the DC power source cable leads is 0 V and that there is no chance that the cable leads might become active during installation.
2. Secure the power cable lugs to the terminal studs, first with the split washers, then with the nuts as shown in Figure 11 on page 16. Apply between 23 lb-in. (2.6 Nm) and 25 lb-in. (2.8 Nm) of torque to each nut. Do not overtighten the nut. (Use a 7/16-in. torque-controlled driver or socket wrench.)
 - a. Attach the positive (+) DC source power cable lug to the **RTN** (return) terminal.
 - b. Attach the negative (-) DC source power cable lug to the **-48V** (input) terminal.

Figure 11: Connect Power Cables

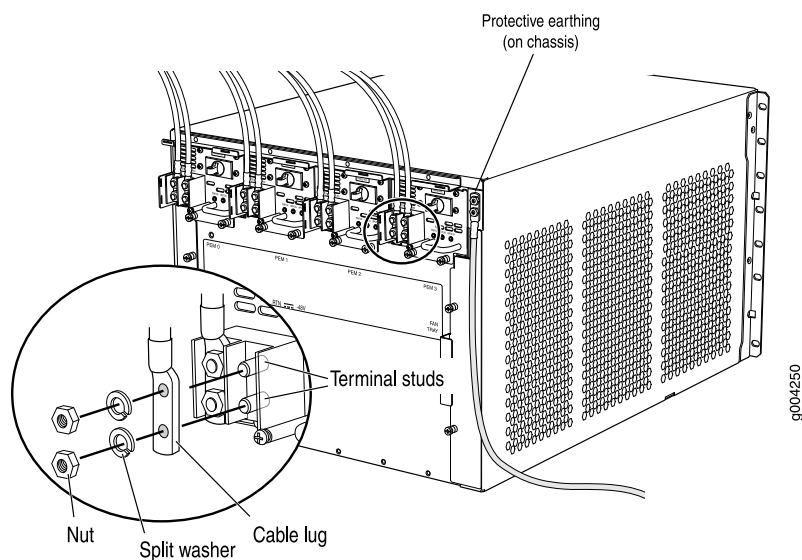

CAUTION: Ensure that each power cable lug seats flush against the surface of the terminal block as you are tightening the nuts. Ensure that each nut is properly threaded onto the terminal stud. The nut should be able to spin freely with your fingers when it is first placed onto the terminal stud. Applying installation torque to the nut when improperly threaded may result in damage to the terminal stud.



CAUTION: The maximum torque rating of the terminal studs on the DC power supply is 36 lb-in. (4.0 Nm). The terminal studs may be damaged if excessive torque is applied. Use only a torque-controlled driver or socket wrench to tighten nuts on the DC power supply terminal studs.



NOTE: For information about connecting to DC power sources, see the *SRX5600 Services Gateway Hardware Guide*.

3. Connect each DC power cable to the appropriate external DC power source.



NOTE: For information about connecting to external DC power sources, see the *SRX5600 Services Gateway Hardware Guide*.

4. Switch on the power supply breakers to provide voltage to the DC power source cable leads.

Proceed to “Step 7: Perform the Initial Software Configuration” on page 17.

Step 7: Perform the Initial Software Configuration

This procedure connects the services gateway to the network but does not enable it to forward traffic. For complete information about enabling the services gateway to forward traffic, including examples, see the appropriate Junos operating system (JunosOS) configuration guides.

To configure the software:

- Enter Configuration Mode on page 17
- Configure User Accounts and Passwords on page 18
- Configure System Attributes on page 18
- Commit the Configuration on page 19

Enter Configuration Mode

1. If you have not already done so, switch the circuit breaker or toggle switch for each power supply to the **ON** position to start the device. The **OK** LED on the power supply faceplate should blink, and then light steadily.
2. Log in as the root user. There is no password.
3. Start the CLI.

```
root# cli
root@>
```

4. Enter configuration mode.

```
configure
[edit]
root@#
```

Configure User Accounts and Passwords

1. Set the root authentication password by entering a cleartext password, an encrypted password, or an SSH public key string (DSA or RSA).

```
[edit]
root@# set system root-authentication plain-text-password
New password: password
Retype new password: password
```

2. Configure an administrator account on the device. When prompted, enter the password for the administrator account.

```
[edit]
root@# set system login user admin class super-user authentication
      plain-text-password
New password: password
Retype new password: password
```

3. Commit the configuration to activate it on the services gateway.

```
[edit]
root@# commit
```

Configure System Attributes

1. Log in as the administrative user that you configured earlier.
2. Configure the name of the services gateway. If the name includes spaces, enclose the name in quotation marks (" ").

```
configure
[edit]
admin@# set system host-name host-name
```

3. Configure the IP address and prefix length for the services gateway Ethernet interface.

```
[edit]
admin@# set interfaces fxp0 unit 0 family inet address address/prefix-length
```

4. Configure the traffic interface.

```
[edit]
admin@# set interfaces ge-6/2/0 unit 0 family inet address address/prefix-length
admin@# set interfaces ge-6/3/5 unit 0 family inet address address/prefix-length
```

5. Configure the default route.

```
[edit]
admin@# set routing-options static route 0.0.0.0/0 next-hop gateway
```

6. Configure basic security zones and bind them to traffic interfaces.

```
[edit]
admin@# set security zones security-zone trust interfaces ge-6/3/5
admin@# set security zones security-zone untrust interfaces ge-6/2/0
```

7. Configure basic security policies.

```
[edit]
```

```

admin@# set security policies from-zone trust to-zone untrust policy policy-name
      match source-address any destination-address any application any
root@# set security policies from-zone trust to-zone untrust policy policy-name then
      permit

```

Commit the Configuration

1. Check the configuration for validity.

```

[edit]
admin@# commit check
configuration check succeeds

```

2. Optionally, display the configuration to verify that it is correct.

```

admin@# show

## Last changed: 2008-05-07 22:43:25 UTC
version "9.2.10 [builder]";
system {
  autoinstallation;
  host-name henbert;
  root-authentication {
    encrypted-password "$1$oTVn2KY3$uQe4xzQCxpR2j7sKuV.Pa0"; ##
    SECRET-DATA
  }
  login {
    user admin {
      uid 928;
      class super-user;
      authentication {
        encrypted-password "$1$cdOPmACd$QvreBsJkNR1EF0uurTBkE."; ##
        SECRET-DATA
      }
    }
  }
}
services {
  ssh;
  web-management {
    http {
      interface ge-0/0/0.0;
    }
  }
}
syslog {
  user * {
    any emergency;
  }
  file messages {
    any any;
    authorization info;
  }
  file interactive-commands {
    interactive-commands any;
  }
}
license {

```

```
    autoupdate {
      url https://ae1.juniper.net/junos/key_retrieval;
    }
  }
}
interfaces {
  ge-0/0/0 {
    unit 0;
  }
  ge-6/2/0 {
    unit 0 {
      family inet {
        address 5.1.1/24;
      }
    }
  }
  ge-6/3/5 {
    unit 0 {
      family inet {
        address 192.1.1/24;
      }
    }
  }
  fxp0 {
    unit 0 {
      family inet {
        address 192.168.10.2/24;
      }
    }
  }
}
routing-options {
  static {
    route 0.0.0.0/0 next-hop 5.1.1.2;
  }
}
security {
  zones {
    security-zone trust {
      interfaces {
        ge-6/3/5.0;
      }
    }
    security-zone untrust {
      interfaces {
        ge-6/2/0.0;
      }
    }
  }
  policies {
    from-zone trust to-zone untrust {
      policy bob {
        match {
          source-address any;
          destination-address any;
          application any;
        }
      }
    }
  }
}
```

```

    }
    then {
      permit;
    }
  }
}
}
}

```

3. Commit the configuration to activate it on the services gateway.

```

[edit]
admin@# commit

```

4. Optionally, configure additional properties by adding the necessary configuration statements. Then commit the changes to activate them on the services gateway.

```

[edit]
admin@# commit

```

5. When you have finished configuring the services gateway, exit configuration mode.

```

[edit]
admin@# exit
admin@>

```

Safety Warnings



.....

WARNING: See installation instructions before connecting the services gateway. This is a summary of safety warnings. For a complete list of warnings for the services gateway, including translations, see the *SRX5600 Services Gateway Hardware Guide* at <http://www.juniper.net/techpubs/hardware/>.

.....



.....

WARNING: The intrabuilding port(s) of the services gateway is suitable for connection to intrabuilding or unexposed wiring or cabling only. The intrabuilding port(s) of the services gateway **MUST NOT** be metallically connected to interfaces that connect to the outside plant (OSP) or its wiring. These interfaces are designed for use as intrabuilding interfaces only (Type 2 or Type 4 ports as described in GR-1089-CORE, Issue 4) and require isolation from the exposed OSP cabling. The addition of primary protectors is not sufficient protection to connect these interfaces metallically to OSP wiring.

.....



.....

CAUTION: Before removing or installing components of a services gateway, attach an ESD strap to an ESD point, and place the other end of the strap around your bare wrist. Failure to use an ESD strap could result in damage to the services gateway.

.....



CAUTION: An external surge protective device (SPD) should be used at the AC input of the services gateway.

- Only trained and qualified personnel should install or replace the services gateway.
- Perform only the procedures described in this guide or the *SRX5600 Services Gateway Hardware Guide*. Other services should be performed by authorized service personnel only.
- Read the installation instructions before you connect the services gateway to a power source.
- Before installing the services gateway, read the guidelines for site preparation in the *SRX5600 Services Gateway Hardware Guide* to make sure that the site meets power, environmental, and clearance requirements for the services gateway.
- For the cooling system to function properly, the airflow around the chassis must be unrestricted. Allow at least 6 in. (15.2 cm) of clearance between side-cooled devices. Allow 2.8 in. (7 cm) between the side of the chassis and any non-heat-producing surface such as a wall.
- When installing the services gateway, do not use a ramp inclined more than 10 degrees.
- Manually installing the services gateway requires at least two people to lift the chassis. Before lifting the chassis, remove components as described in the *SRX5600 Services Gateway Hardware Guide*. To prevent injury, keep your back straight and lift with your legs, not your back. Do not attempt to lift the chassis by the power supply handles.
- The services gateway should be mounted at the bottom of the rack if it is the only unit in the rack.
- When mounting the services gateway in a partially filled rack, load the rack from the bottom to the top, with the heaviest component at the bottom of the rack.
- If the rack is provided with stabilizing devices, install the stabilizers before mounting or servicing the services gateway in the rack.
- When removing or installing an electrical component, always place it component-side up on a flat antistatic surface or in an electrostatic bag.
- When you install the services gateway, always make the ground connection first and disconnect it last.
- Wire the DC power supply using the appropriate lugs. When connecting power, the proper wiring sequence is ground to ground, +RTN to +RTN, and then -48 V to -48 V. When disconnecting power, the proper wiring sequence is -48 V to -48 V, +RTN to +RTN, and then ground to ground. Always connect the ground wire first and disconnect it last.
- Do not work on the system or connect or disconnect cables during electrical storms.
- Before working on equipment that is connected to power lines, remove jewelry, including rings, necklaces, and watches. Metal objects heat up when connected to power and ground and can cause serious burns or become welded to the terminals.

- Failure to observe these safety warnings can result in serious physical injury.
- AC power cable warning (Japan):



WARNING: The attached power cable is only for this product. Do not use the cable for another product.

注意

附属の電源コードセットはこの製品専用です。
他の電気機器には使用しないでください。

g017253

SRX5600 Services Gateway Compliance Statements for EMC Requirements

- Canada on page 23
- European Community on page 23
- Japan on page 23
- United States on page 24

Canada

This Class A digital apparatus complies with Canadian ICES-003.

Cet appareil numérique de la classe A est conforme à la norme NMB-003 du Canada.

European Community

This is a Class A product. In a domestic environment this product may cause radio interference in which case the user may be required to take adequate measures.

Japan

この装置は、情報処理装置等電波障害自主規制協議会（VCCI）の基準に基づくクラスA 情報技術装置です。この装置は、家庭環境で使用することを目的としていますが、この装置がラジオやテレビジョン受信機に近接して使用されると、受信障害を引き起こすことがあります。

取扱説明書に従って正しい取り扱いをして下さい。

The preceding translates as follows:

This is a Class A product based on the standard of the Voluntary Control Council for Interference by Information Technology Equipment (VCCI). If this product is used near a radio or television receiver in a domestic environment, it may cause radio interference. Install and use the equipment according to the instruction manual.

United States

The services gateway has been tested and found to comply with the limits for a Class A digital device of the FCC Rules. These limits are designed to provide reasonable protection against harmful interference when the equipment is operated in a commercial environment. This equipment generates, uses, and can radiate radio frequency energy and, if not installed and used in accordance with the instruction manual, may cause harmful interference to radio communications. Operation of this equipment in a residential area is likely to cause harmful interference in which case the user will be required to correct the interference at his own expense.

SRX Series Documentation and Release Notes

For a list of related SRX Series documentation, see <http://www.juniper.net/techpubs/hardware/srx-series-main.html> .

For a list of related Junos documentation, see <http://www.juniper.net/techpubs/software/junos/> .

If the information in the latest release notes differs from the information in the documentation, follow the *Junos Release Notes*.

To obtain the most current version of all Juniper Networks technical documentation, see the product documentation page on the Juniper Networks website at <http://www.juniper.net/techpubs/> .

Requesting Technical Support

Technical product support is available through the Juniper Networks Technical Assistance Center (JTAC). If you are a customer with an active J-Care or JNASC support contract, or are covered under warranty, and need postsales technical support, you can access our tools and resources online or open a case with JTAC.

- JTAC policies—For a complete understanding of our JTAC procedures and policies, review the JTAC User Guide located at <http://www.juniper.net/customers/support/downloads/710059.pdf> .
- Product warranties—For product warranty information, visit <http://www.juniper.net/support/warranty/> .
- JTAC Hours of Operation—The JTAC centers have resources available 24 hours a day, 7 days a week, 365 days a year.

Self-Help Online Tools and Resources

For quick and easy problem resolution, Juniper Networks has designed an online self-service portal called the Customer Support Center (CSC) that provides you with the following features:

- Find CSC offerings: <http://www.juniper.net/customers/support/>
- Find product documentation: <http://www.juniper.net/techpubs/>
- Download the latest versions of software and review release notes: <http://www.juniper.net/customers/csc/software/>
- Find solutions and answer questions using our Knowledge Base: <http://kb.juniper.net/>
- Search technical bulletins for relevant hardware and software notifications: <https://www.juniper.net/alerts/>
- Join and participate in the Juniper Networks Community Forum: <http://www.juniper.net/company/communities/>
- Open a case online in the CSC Case Manager: <http://www.juniper.net/cm/>

To verify service entitlement by product serial number, use our Serial Number Entitlement (SNE) Tool located at <https://tools.juniper.net/SerialNumberEntitlementSearch/>.

Opening a Case with JTAC

You can open a case with JTAC on the Web or by telephone.

- Use the Case Manager tool in the CSC at <http://www.juniper.net/cm/>.
- Call 1-888-314-JTAC (1-888-314-5822 toll-free in the USA, Canada, and Mexico).

For international or direct-dial options in countries without toll-free numbers, visit us at <http://www.juniper.net/support/requesting-support.html>.

Revision History

August 2008—530-026090-01 Revision 01 Initial release

August 2008—530-026090-01 Revision 02 IOC terminology change

February 2011—530-038206 Revision 01 Minor changes

Copyright © 2011, Juniper Networks, Inc. All rights reserved.

Juniper Networks, Junos, Steel-Belted Radius, NetScreen, and ScreenOS are registered trademarks of Juniper Networks, Inc. in the United States and other countries. The Juniper Networks Logo, the Junos logo, and JunosE are trademarks of Juniper Networks, Inc. All other trademarks, service marks, registered trademarks, or registered service marks are the property of their respective owners.

Juniper Networks assumes no responsibility for any inaccuracies in this document. Juniper Networks reserves the right to change, modify, transfer, or otherwise revise this publication without notice.

Products made or sold by Juniper Networks or components thereof might be covered by one or more of the following patents that are owned by or licensed to Juniper Networks: U.S. Patent Nos. 5,473,599, 5,905,725, 5,909,440, 6,192,051, 6,333,650, 6,359,479, 6,406,312, 6,429,706, 6,459,579, 6,493,347, 6,538,518, 6,538,899, 6,552,918, 6,567,902, 6,578,186, and 6,590,785.