

# JCS1200 Control System Quick Start

August 2010  
Part Number: 530-035420  
Revision 01

## Contents

Quick Start Description . . . . .	3
Step 1: Prepare the Site . . . . .	3
Rack-Mounting Requirements . . . . .	3
Tools Required to Install the JCS1200 Platform . . . . .	4
Step 2: Install the JCS1200 Mounting Hardware . . . . .	5
Rack Mounting Hole Locations for the JCS1200 Platform . . . . .	5
Install the JCS1200 Mounting Hardware in a Four-Post Rack or Cabinet . . . . .	6
Install Cage Nuts in a Four-Post Rack or Cabinet, If Needed . . . . .	6
Install the Large Mounting Shelf in a Four-Post Rack or Cabinet . . . . .	7
Install the Small Mounting Shelf in a Four-Post Rack or Cabinet . . . . .	7
Install the Mounting Brackets on the JCS1200 Platform . . . . .	7
Install the JCS1200 Mounting Hardware in an Open-Frame Rack . . . . .	7
Install Cage Nuts in an Open-Frame Rack, If Needed . . . . .	8
Install the Large Mounting Shelf in an Open-Frame Rack . . . . .	8
Install the Mounting Brackets on the JCS1200 Platform . . . . .	9
Step 3: Install the JCS1200 Platform . . . . .	9
Remove Components from the JCS1200 Platform . . . . .	9
Install the JCS1200 Platform Using a Lift . . . . .	10
Lift the JCS1200 Platform into the Rack or Cabinet . . . . .	12
Reinstall Components into the JCS1200 Platform . . . . .	13
Step 4: Connect the JCS1200 Platform to Power . . . . .	13
Connect the JCS1200 AC Platform to AC Power . . . . .	13
Connect the JCS1200 DC Platform to DC Power . . . . .	13
Step 5: Connect the JCS1200 Platform . . . . .	17
Tools and Parts Required to Connect the JCS1200 Platform . . . . .	17
Connect the JCS1200 Management Module to the Network . . . . .	17
Connect the JCS1200 Management Module to the Network Through a Network Ethernet Connection . . . . .	18
Connect the JCS1200 Management Module to a Client Computer Through an Ethernet Connection . . . . .	18
Connect the JCS1200 Management Module to the Network Through a Serial Connection . . . . .	18

Connect the JCS1200 Management Module to a Client Computer	
Through a Serial Connection . . . . .	19
Connect a Console to the JCS1200 Routing Engines . . . . .	20
Step 6: Integrate an Offline T Series Core Router with the JCS1200 Platform . . .	20
Replace the Standard CBs in the T Series Core Router . . . . .	21
Connect an Offline T Series Core Router to the JCS1200 Platform . . . . .	21
Step 7: Power On the T Series Core Router . . . . .	24
Step 8: Configure the Software for the JCS1200 Platform . . . . .	24
Configure the JCS1200 Management Module . . . . .	25
Configure the JCS1200 Routing Engines . . . . .	25
Safety Warnings . . . . .	25
Compliance Statements for NEBS for JCS1200 Platforms . . . . .	29
Compliance Statements for EMC Requirements for the JCS1200 Platform . . . . .	29
Australia and New Zealand . . . . .	29
Canada . . . . .	29
China . . . . .	30
European Community . . . . .	30
Declaration of Conformity . . . . .	30
Japan . . . . .	31
Taiwan . . . . .	32
United Kingdom . . . . .	32
United States . . . . .	32
Junos Documentation and Release Notes . . . . .	32
Requesting Technical Support . . . . .	33
Self-Help Online Tools and Resources . . . . .	33
Opening a Case with JTAC . . . . .	33
Revision History . . . . .	34

---

## Quick Start Description

---



.....

**WARNING:** This Quick Start contains a summary of safety warnings in “Safety Warnings” on page 25. For a complete list of warnings for this platform, including translations, see the *JCS1200 Control System Hardware Guide* at <http://www.juniper.net/techpubs/hardware/>.

.....

The JCS1200 Control System is a high-density, high-performance rack-mounted control and Routing Engine platform. The JCS1200 platform provides 12 bays for Routing Engines and other JCS1200 platform components, integrating common resources that are shared by the Routing Engines. The use of common resources provides a small server-system footprint that contains high-performing servers with minimal cabling.

The JCS1200 platform is a modular, rack-mountable system. The JCS1200 platform is shipped in a wooden crate. A wooden pallet forms the base of the crate. The JCS1200 chassis is bolted to this pallet. The shipping crate contains:

- One accessory box (the box to which this Quick Start is taped)
- One Juniper Networks JCS1200 platform
- One Quick Start (this document)



.....

**NOTE:** This Quick Start explains how to integrate an offline T Series Core router with the JCS1200 platform. For more information, see the *JCS1200 Control System Hardware Guide* at <http://www.juniper.net/techpubs>.

.....

## Step 1: Prepare the Site

---

Before installing the JCS1200 platform, make sure that the site meets all the power, environmental, and clearance requirements. See the site preparation guidelines in the *JCS1200 Control System Hardware Guide*.

- Rack-Mounting Requirements on page 3
- Tools Required to Install the JCS1200 Platform on page 4

### Rack-Mounting Requirements

The JCS1200 platform can be installed in many types of racks. Follow these guidelines:

- The rack rails must be spaced widely enough to accommodate the JCS1200 chassis's external dimensions: 20.7 in. (53.34 cm) high, 27.75 in. (70.5 cm) deep, and 17.43 in. (44.3 cm) wide.
- The rack must be strong enough to support the weight of the fully configured JCS1200 platform, up to about 350 lb (158.8 kg).

- If you must install another device in the rack, consider the height and weight of the JCS1200 platform and the cable management above the chassis, including the optional cable shelf assembly.
- For service personnel to remove and install hardware components, there must be adequate space at the front and back of the JCS1200 platform. Allow at least 24 in. (61.0 cm) both in front of and behind the JCS1200 platform. NEBS GR-63 recommends at least 30 in. in front of the JCS1200 platform (see Figure 1 on page 4).
- The rack or cabinet must have an adequate supply of cooling air.
- In a closed cabinet, there must be a minimum of 6 in. (15.2 cm) of unobstructed airflow behind the JCS1200 platform, or airflow baffles must be installed to prevent recirculation of hot air and overheating.

**Figure 1: Chassis Dimensions and Clearance Requirements for the JCS1200 Platform**

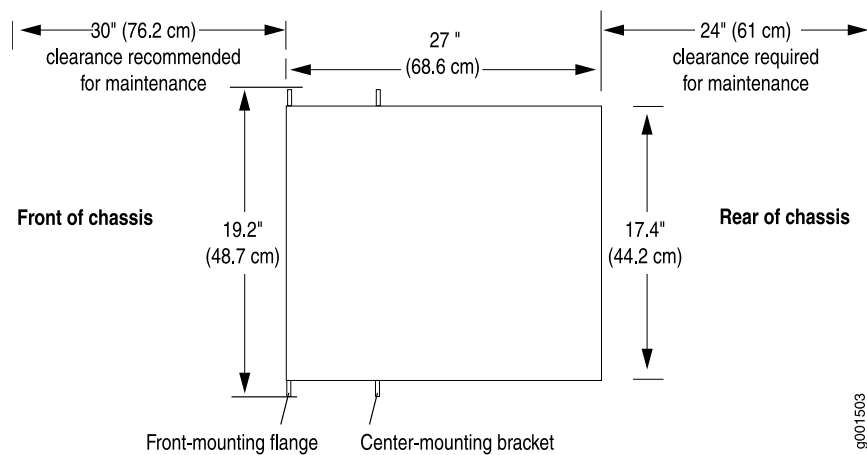

### Tools Required to Install the JCS1200 Platform

- A mechanical lift (strongly recommended)
- 7/16-in. hexagonal-head external drive socket wrench
- 1/2-in. or 13 mm open-end or socket wrench for removing chassis from pallet
- Phillips (+) screwdriver, number 2
- Antistatic mat
- Wire cutters
- Pliers
- Electrostatic discharge (ESD) grounding wrist strap
- Blank panels to cover any slots not occupied by a component

## Step 2: Install the JCS1200 Mounting Hardware

- Rack Mounting Hole Locations for the JCS1200 Platform on page 5
- Install the JCS1200 Mounting Hardware in a Four-Post Rack or Cabinet on page 6
- Install the JCS1200 Mounting Hardware in an Open-Frame Rack on page 7

### Rack Mounting Hole Locations for the JCS1200 Platform

Table 1 on page 5 specifies the holes in which you insert mounting screws (and cage nuts if needed) to install the mounting hardware required in a four-post or two-post open-frame rack (an X indicates a mounting hole location). The hole distances are relative to one of the standard U divisions on the rack. The bottom of all mounting shelves is at 0.04 in. (0.02 U) above a U division.

**Table 1: Open-Frame Rack Mounting Hole Locations**

Hole	Distance Above U Division		Large Shelf	Chassis	Small Shelf
30	17.26 in. (43.8 cm)	9.86 U	X		
27	15.51 in. (39.4 cm)	8.86 U	X		
24	13.76 in. (34.9 cm)	7.86 U	X	X	
21	12.01 in. (30.5 cm)	6.86 U	X	X	
18	10.26 in. (26.0 cm)	5.86 U	X	X	
15	8.51 in. (21.6 cm)	4.86 U	X	X	
12	6.76 in. (17.1 cm)	3.86 U	X	X	
9	5.01 in. (12.7 cm)	2.86 U	X		
6	3.26 in. (8.3 cm)	1.86 U	X		
3	1.51 in. (3.8 cm)	0.86 U	X		X
2	0.88 in. (2.2 cm)	0.50 U	X		X
1	0.25 in. (0.6 cm)	0.14 U			X

#### Related Documentation

- JCS1200 Platform Rack-Mounting Hardware
- Rack-Mounting Requirements and Warnings for the JCS1200 Platform
- Installing the JCS1200 Mounting Hardware for a Four-Post Rack or Cabinet
- Installing the JCS1200 Mounting Hardware for an Open-Frame Rack

## Install the JCS1200 Mounting Hardware in a Four-Post Rack or Cabinet

Figure 2: Install the JCS1200 Mounting Hardware for a Four-Post Rack or Cabinet

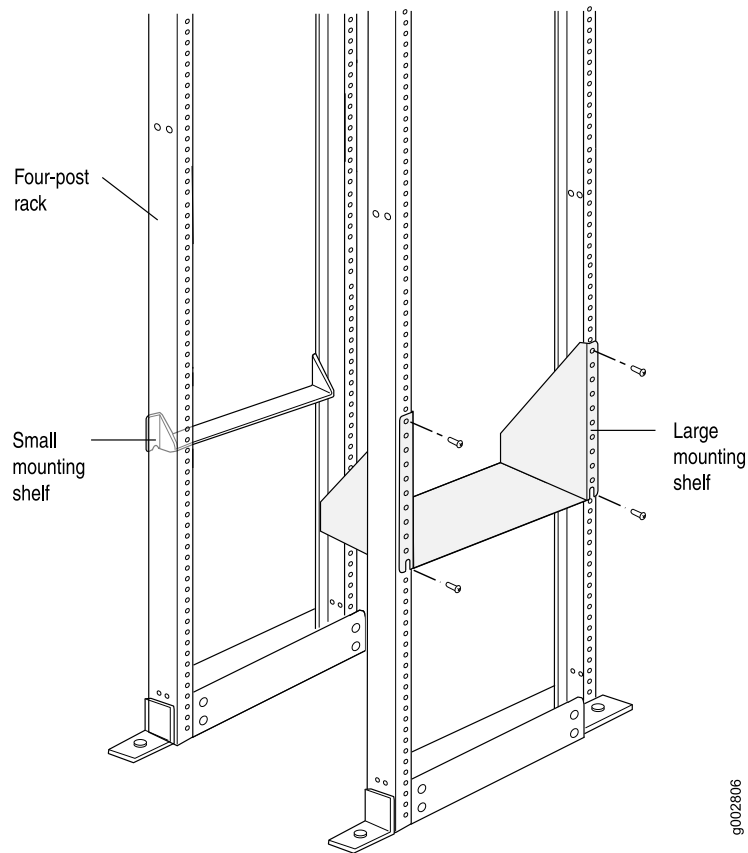

To install the mounting hardware in a four-post rack or cabinet:

- Install Cage Nuts in a Four-Post Rack or Cabinet, If Needed on page 6
- Install the Large Mounting Shelf in a Four-Post Rack or Cabinet on page 7
- Install the Small Mounting Shelf in a Four-Post Rack or Cabinet on page 7
- Install the Mounting Brackets on the JCS1200 Platform on page 7

### Install Cage Nuts in a Four-Post Rack or Cabinet, If Needed

For racks without threaded holes, you must install cage nuts in the locations specified in Table 1 on page 5:

- On each front rack rail, install cage nuts for the large shelf.
- On each rear rack rail, install cage nuts for the small shelf.

### Install the Large Mounting Shelf in a Four-Post Rack or Cabinet

1. On the front of each front rack rail, partially insert a mounting screw into the hole containing the lowest cage nut.
2. Install the large shelf on the front rack rails. Rest the bottom slot of each ear on a mounting screw.
3. Partially insert a mounting screw into the holes 3, 6, 9, and 30 in each ear of the large shelf.
4. Tighten all the screws completely.

### Install the Small Mounting Shelf in a Four-Post Rack or Cabinet

1. On the back side of each rear rack rail, partially insert a mounting screw into the hole containing the lowest cage nut.
2. Install the small shelf on the back rack rails. Rest the bottom slot of each ear on a mounting screw. The small shelf installs on the back of the rear rails, extending toward the center of the rack. The bottom of the small shelf should align with the bottom of the large shelf.
3. Partially insert screws into the open holes in the ears of the small shelf.
4. Tighten all the screws completely.

### Install the Mounting Brackets on the JCS1200 Platform

Attach the front-mounting brackets to the side of the chassis using six of the mounting screws provided.

### Install the JCS1200 Mounting Hardware in an Open-Frame Rack

For open-frame racks, center-mounting provides more even weight distribution and stability. The small mounting shelf is not needed for open-frame racks.

Figure 3: Install the JCS1200 Mounting Hardware for an Open-Frame Rack

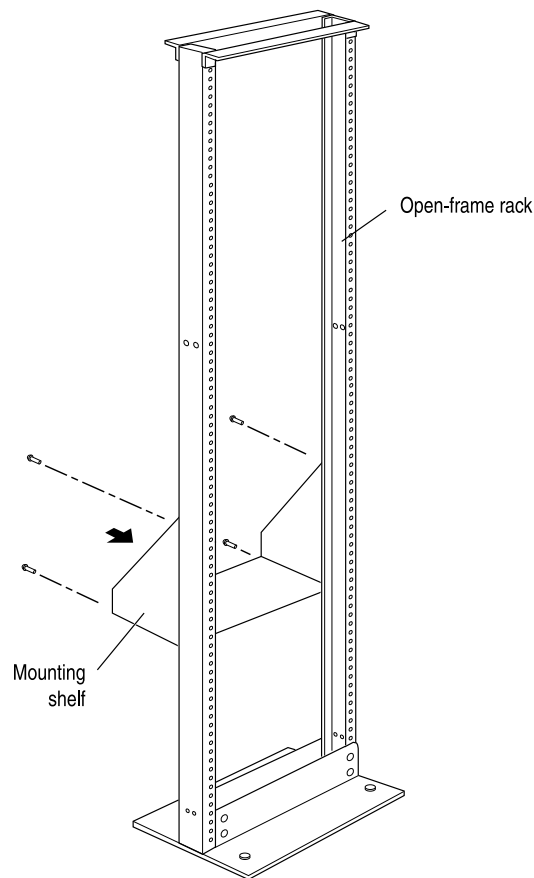

To install the mounting hardware for an open-frame rack:

- Install Cage Nuts in an Open-Frame Rack, If Needed on page 8
- Install the Large Mounting Shelf in an Open-Frame Rack on page 8
- Install the Mounting Brackets on the JCS1200 Platform on page 9

#### Install Cage Nuts in an Open-Frame Rack, If Needed

For racks without threaded holes, you must install cage nuts in the locations specified in Table 1 on page 5:

- On the rear side of rack rails, install cage nuts for the large shelf.
- On the front side of rack rails, install cage nuts for the chassis.

#### Install the Large Mounting Shelf in an Open-Frame Rack

1. On the rear of each rack rail, partially insert a mounting screw into the highest hole specified in Table 1 on page 5 for the large shelf
2. Install the large shelf on the rack. Hang the shelf over the mounting screws using the keyhole slots located near the top of the large shelf flanges.

3. Partially insert screws into the rest of the holes specified in Table 1 on page 5 for each ear of the large shelf.
4. Tighten all the screws completely.

### Install the Mounting Brackets on the JCS1200 Platform

The JCS1200 platform is shipped with two front-mounting and two center-mounting brackets.

- If you plan to front-mount the chassis in an open-frame rack, attach the front-mounting brackets to the side of the chassis using six of the mounting screws provided.
- If you plan to center-mount the chassis in an open-frame rack, attach the center-mounting brackets to the side of the chassis using the eight mounting screws provided.

## Step 3: Install the JCS1200 Platform

---

1. Read “Safety Warnings” on page 25.
2. Remove components as described in “Remove Components from the JCS1200 Platform” on page 9.
3. Because of the JCS1200 platform's size and weight, we recommend you install the chassis using a mechanical lift. Install the JCS1200 Platform as described in one of the following subsections.
  - Install the JCS1200 Platform Using a Lift on page 10
  - Lift the JCS1200 Platform into the Rack or Cabinet on page 12
4. Reinstall the components as described in “Reinstall Components into the JCS1200 Platform” on page 13

### Remove Components from the JCS1200 Platform

To reduce the weight of your JCS1200 platform, remove the following components from the JCS1200 platform.

- Fan modules
- Fan shuttle
- Management modules
- Media trays
- Power modules
- Routing Engines
- Switch modules



NOTE: For detailed instructions on removing JCS1200 components, see the *JCS1200 Control System Hardware Guide*.

1. Attach an electrostatic discharge (ESD) grounding strap to your bare wrist, and connect the strap to an approved site ESD grounding point. See the instructions for your site.
2. Slide each component out of the chassis evenly so that it does not become stuck or damaged.
3. Label each component as you remove it so you can reinstall it in the correct location.
4. Immediately store each removed component in an electrostatic bag.
5. Do not stack removed components. Lay each one on a flat surface.

### Install the JCS1200 Platform Using a Lift

1. If you are installing the platform in an open-frame rack, ensure that the rack is in its permanent location and is secured to the building. Ensure that the installation site allows adequate clearance for both airflow and maintenance. For details, see “Step 1: Prepare the Site” on page 3.
2. Load the JCS1200 platform onto the lift, making sure it rests securely on the lift platform.
3. Using the lift, position the JCS1200 platform in front of the rack or cabinet, centering it in front of the mounting shelves.
4. Lift the chassis approximately 0.75 in. (1.91 cm) above the surface of the mounting shelves and position it as close as possible to the shelves.
5. Carefully slide the JCS1200 platform onto the mounting shelves so that the bottom of the chassis and the mounting shelves overlap by approximately 2 in.
6. With two people pulling on the rear of the chassis and two people pushing on the mounting flanges, slide the JCS1200 platform onto the mounting shelves until the front or center-mounting flanges contact the rack rails. The shelves ensure that the holes in the mounting flanges align with the holes in the rack rails.
7. Install a mounting screw into each of the open mounting holes in the rack-mounting flanges to fasten the chassis to the rack, starting from the bottom.
8. Move the lift away from the rack.
9. Visually inspect the alignment of the JCS1200 platform. If the JCS1200 platform is installed properly in the rack, all the mounting screws on one side of the rack should be aligned with the mounting screws on the opposite side, and the platform should be level.

Figure 4: Install the JCS1200 Platform in a Four-Post Rack

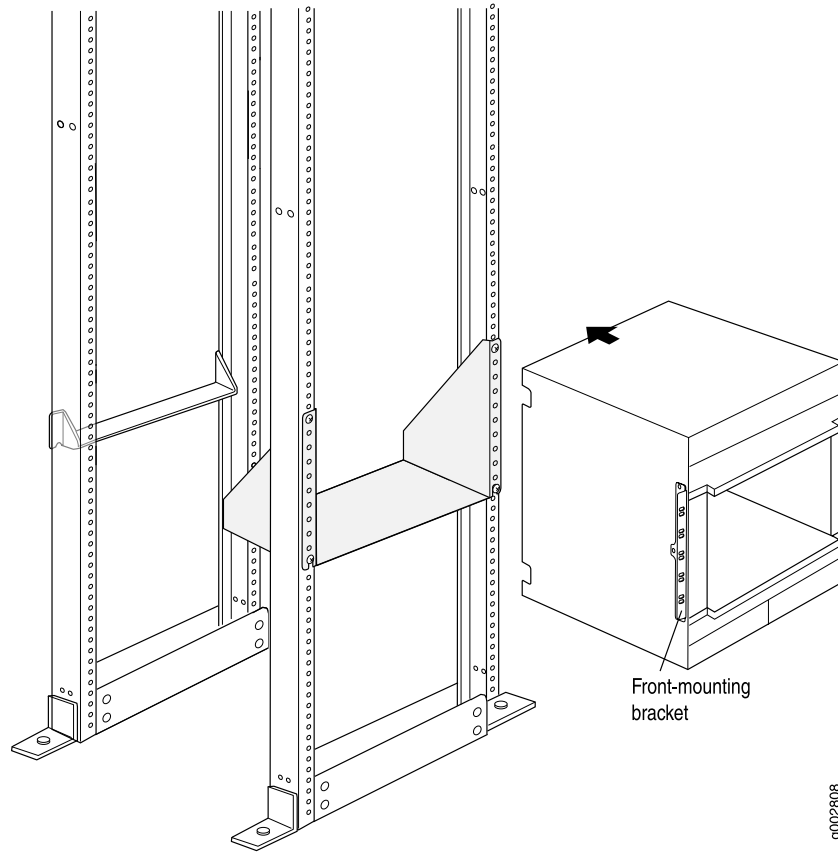
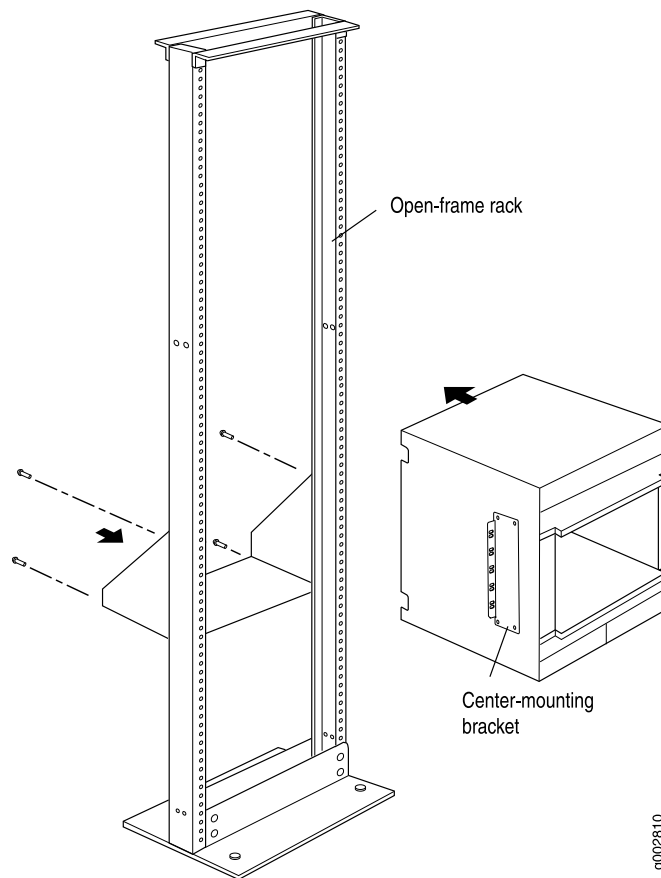

Figure 5: Install the JCS1200 Platform in an Open-Frame Rack



### Lift the JCS1200 Platform into the Rack or Cabinet

Because of the JCS1200 platform's size and weight—up to 350 lb (158.8 kg) depending on the configuration—we strongly recommend that you install the JCS1200 platform using a mechanical lift, as described in “Install the JCS1200 Platform Using a Lift” on page 10.

Lifting the chassis without a lift and mounting it in a rack requires four people. The empty chassis weighs approximately 229 lb (99.82 kg).

1. Ensure the rack is in its permanent location and is secured to the building.
2. Position the JCS1200 platform in front of the rack or cabinet, centering it in front of the mounting shelves. Use a pallet jack if one is available.
3. With two people in the front and two people in the back, hold onto the bottom of the chassis and carefully lift it onto the mounting shelves.
4. Carefully slide the JCS1200 platform onto the mounting shelves so that the bottom of the chassis and the mounting shelves overlap by approximately 2 in.

5. Install a mounting screw into each of the open mounting holes in the rack-mounting flanges to fasten the chassis to the rack, starting from the bottom.
6. Visually inspect the alignment of the JCS1200 platform. If the JCS1200 platform is installed properly in the rack, all the mounting screws on one side of the rack should be aligned with the mounting screws on the opposite side, and the platform should be level.

## Reinstall Components into the JCS1200 Platform



NOTE: For detailed instructions on reinstalling JCS1200 components, see the *JCS1200 Control System Hardware Guide*.

1. Attach an electrostatic discharge (ESD) grounding strap to your bare wrist, and connect the strap to an approved site ESD grounding point. See the instructions for your site.
2. Slide each component into the chassis evenly so that it does not become stuck or damaged.
3. Tighten screws, as needed, for each component.



NOTE: Make sure that all empty slots are covered with a blank panel before operating the JCS1200 platform.

## Step 4: Connect the JCS1200 Platform to Power

- Connect the JCS1200 AC Platform to AC Power on page 13
- Connect the JCS1200 DC Platform to DC Power on page 13

### Connect the JCS1200 AC Platform to AC Power

The JCS1200 platform has four AC power C20 input connectors. Use two C20/C19 type AC jumper cords to connect AC power to the JCS1200 platform.

1. Attach an electrostatic discharge (ESD) grounding strap to your bare wrist, and connect the strap to an approved site ESD grounding point. See the instructions for your site.
2. Connect one end of each power cord to a power connector on the rear of the JCS1200 platform.
3. Connect the other end of each power cord to a 200-240 volt, 20-amp power distribution unit or appropriate electrical outlet. An external surge protective device (SPD) is not required at the AC power input of the JCS1200 platform.

### Connect the JCS1200 DC Platform to DC Power

The JCS1200 DC power inputs are configured for DC isolated return (DC-I). The DC return terminal or conductor is not connected to the equipment frame or the grounding means of the equipment.

The JCS1200 DC platform has four DC power terminal connectors (see Figure 6 on page 14). Each DC terminal has four M6 (0.25-inch) studs, one for -48 V DC, one for RETURN (RTN), and two for connecting the grounding cable.

**Figure 6: DC Power Terminal Connectors**

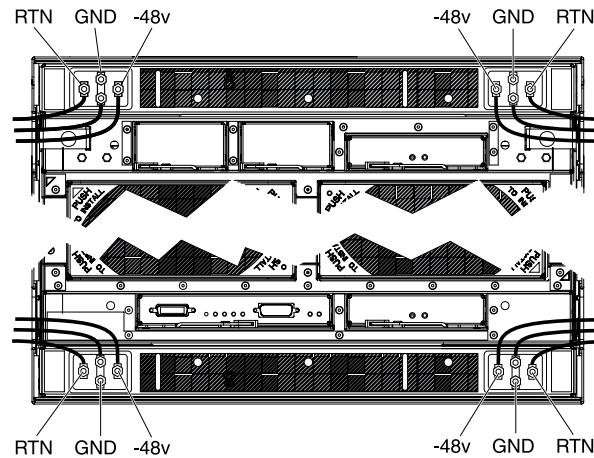

To connect the JCS1200 DC platform to DC power:

1. Ensure that the voltage across the DC power source cable leads is 0 V and that there is no chance that the cable leads might become active during installation.
2. Verify that a licensed electrician has attached the cable lugs to the power cables.
3. Switch both circuit breakers on the power supply faceplate to the off position (O).
4. Attach an electrostatic discharge (ESD) grounding strap to your bare wrist, and connect the strap to an approved site ESD grounding point. See the instructions for your site.
5. Remove the terminal cover for each terminal:
  - a. Remove the two Phillips-head screws that attach the terminal cover to the DC power box.
  - b. Pull the terminal cover away from the JCS1200 platform.
6. Attach the lugs on the DC source power cables to the terminal studs, making sure the cables are not touching or in the way of any JCS1200 platform components. When connecting a cable lug to each stud, install a flat washer on the stud, install the cable lug, install a flat washer, install a split washer, and then install a nut (see Figure 7 on page 15). Torque the wiring terminal nuts to 13.3 lb-in. (1.5 Nm).

Figure 7: Attach the Cable Lugs to the DC Power Terminal Connectors

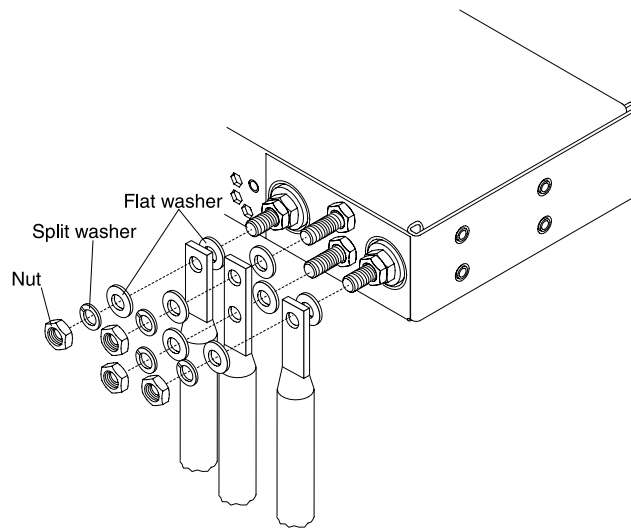

- a. Attach the positive (+) DC source power cable lugs to the **RTN** (return) terminals.
  - b. Attach the negative (–) DC source power cable lugs to the **–48V** (input) terminals.
  - c. Attach the safety ground wire to the other two terminals (**GND**).
7. Verify that the power and ground cabling are correct.
  8. Replace the terminal cover for each terminal:
    - a. Orient the terminal cover so that the terminal cover fits over the DC power terminals and the screw holes on the terminal cover are aligned with the screw holes on the DC power box.
    - b. Install two Phillips-head screws that attach the terminal cover to the DC power box.



.....

**CAUTION:** Only trained service personnel other than Juniper Networks service technicians are authorized to make the connections to and disconnections from the –48 volt DC power source. Juniper Networks service technicians are not certified or authorized to install or remove the –48 volt power cable. The customer is responsible for ensuring that only trained service personnel install or remove the –48 volt power cable.

.....

The following guidelines are provided for connecting a 60-A JCS1200 platform to a –48 V DC power source:

- The power source must have a minimum of 80 A overcurrent protection. See article 240, paragraph 3, table 310-16 of the National Electric Code for more information about electrical wiring requirements.
  - The overcurrent protective device or circuit breaker must be accessible to service personnel to prevent the power from being turned on by someone other than a technician servicing the JCS1200 platform.
  - The JCS1200 platform requires a DC wire rating of 4 AWG (circular mil area of 33100-52600) and of 90° C.
- .....



.....

**NOTE:** The actual wire gauge and ring terminal are determined by the current draw and the length of wire run or as specified by the customer premises guidelines.

.....

- Flexible DC wiring is recommended to allow for minimum bend radius.
- The supply wiring to the power connectors must be terminated in UL-recognized insulated ring terminals, sized for an M6 stud, 4 AWG wire (circular mil area of 33100-52600), and a wire insulation diameter of 12.8 to 13.1 mm. An example of this type of ring terminal is Amp Plasti-Grip type 520431 using Tyco Electronics Hydraulic Crimping Tool part number 14907491.
- For NEBS compliance, the grounding cable must use copper conductors with a size minimum of 6 AWG (circular mil area of 2080033100) and must be terminated in a UL-recognized two-hole lug sized for an M6 stud. An example of this type of two-hole lug is the Thomas and Betts part number 54205 using the Thomas and Betts crimping tool model TBM-25S.
- Torque the wiring-terminal nuts to 13.3 lb-in. (1.5 Nm).

**Related Documentation**

- For safety information, see Safety Warnings on page 25.

## Step 5: Connect the JCS1200 Platform

- Tools and Parts Required to Connect the JCS1200 Platform on page 17
- Connect the JCS1200 Management Module to the Network on page 17
- Connect a Console to the JCS1200 Routing Engines on page 20

### Tools and Parts Required to Connect the JCS1200 Platform

To connect the JCS1200 platform to T Series Core routers, power, and management devices and to power on the platform, you need the following tools and parts:

- 10-mm. hexagonal-head external drive socket wrench, or nut driver, with torque at 13.3 lb-in. (1.5 Nm), for tightening nuts to terminal studs on each terminal connector on a DC-powered platform.



**CAUTION:** Do not substitute a non metric nut driver or wrench. A tool that does not fit the nuts exactly can damage them. If a 10-mm. tool is not available, use pliers or an adjustable wrench.

- Wire cutters
- Pliers
- Electrostatic discharge (ESD) grounding wrist strap

### Connect the JCS1200 Management Module to the Network

The management module supports network connection through an Ethernet port or a serial port (see Figure 8 on page 17).

**Figure 8: Ports on the Management Module**

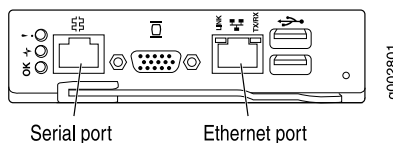

For direct connection of a computer to the management module Ethernet port, you need a Category 5 or higher Ethernet cable.

Network connections through the serial port may require an Advanced Management Module (AMM) adapter. For more information, see the *JCS1200 Control System Hardware Guide*.

The following topics describe how to make typical connections to a management module:

- Connect the JCS1200 Management Module to the Network Through a Network Ethernet Connection on page 18
- Connect the JCS1200 Management Module to a Client Computer Through an Ethernet Connection on page 18

- Connect the JCS1200 Management Module to the Network Through a Serial Connection on page 18
- Connect the JCS1200 Management Module to a Client Computer Through a Serial Connection on page 19

### Connect the JCS1200 Management Module to the Network Through a Network Ethernet Connection

1. Attach an electrostatic discharge (ESD) grounding strap to your bare wrist, and connect the strap to one of the ESD points on the chassis.
2. Connect one end of an Ethernet cable to the Ethernet port on the management module. See Figure 8 on page 17 for the location of ports on the management module.
3. Connect the other end of the Ethernet cable to the network.
4. Check the Ethernet LEDs to make sure that the network connection is working.
  - A lit green Ethernet **LINK** LED indicates that there is an active connection through the port to the network.
  - A flashing green Ethernet activity (**TX/RX**) LED indicates that there is activity through the port over the network link.

### Connect the JCS1200 Management Module to a Client Computer Through an Ethernet Connection

1. Attach an electrostatic discharge (ESD) grounding strap to your bare wrist, and connect the strap to one of the ESD points on the chassis.
2. Connect one end of a Category 5 or higher Ethernet cable to the Ethernet port on the management module. See Figure 8 on page 17 for the location of ports on the management module.
3. Connect the other end of the Ethernet cable to the Ethernet port on the client computer.
4. Check the Ethernet LEDs to make sure that the network connection is working.
  - A lit green Ethernet **LINK** LED indicates that there is an active connection through the port to the network.
  - A flashing green Ethernet activity (**TX/RX**) LED indicates that there is activity through the port over the network link.

For information about establishing a connection to the management module for the first time, see the *JCS1200 Control System Hardware Guide*.

### Connect the JCS1200 Management Module to the Network Through a Serial Connection

1. Attach an electrostatic discharge (ESD) grounding strap to your bare wrist, and connect the strap to one of the ESD points on the chassis.
2. Plug one end of an RJ-45 serial cable into the serial port on the management module. See Figure 8 on page 17 for the location of ports on the management module.



NOTE: Some consoles require that you use an AMM adapter. If needed, plug an AMM adapter into the serial port on the management module, and then connect the serial cable. For information about the AMM adapter pinouts, see the *JCS1200 Control System Hardware Guide*.

3. Connect the other end of the serial cable to your console.

### Connect the JCS1200 Management Module to a Client Computer Through a Serial Connection

1. Attach an electrostatic discharge (ESD) grounding strap to your bare wrist, and connect the strap to one of the ESD points on the chassis.
2. Plug one end of an RJ-45 serial cable into the serial port on the management module. See Figure 8 on page 17 for the location of ports on the management module.



NOTE: For the serial cable characteristics, see the *JCS1200 Control System Hardware Guide*.

3. Connect the other end of the serial cable to the serial connector of the client computer, such as a notebook computer.
4. Configure the serial port of the client computer to the following values:
  - Baud rate—57600
  - Parity—none
  - Stop bits—1

For information about establishing a connection to the management module for the first time, see the *JCS1200 Control System Hardware Guide*.

## Connect a Console to the JCS1200 Routing Engines

To access the Routing Engines from a console, you must use the serial port breakout cable provided with the chassis to connect the JCS1200 platform. The breakout cable provides a direct serial interface to each Routing Engine in the JCS1200 platform and contains 14 RJ-45 serial cable connectors (see Figure 9 on page 20).

Figure 9: Serial Port Breakout Cable

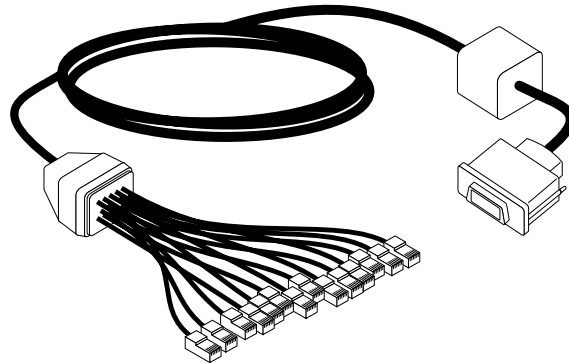

NOTE: Only 12 of the 14 RJ-45 serial cable connectors are used to connect the console to the Routing Engines. Connectors 13 and 14 are reserved for future use.

To connect the console:

1. Attach an electrostatic discharge (ESD) grounding strap to your bare wrist, and connect the strap to an approved site ESD grounding point. See the instructions for your site.
2. Connect the serial connector on the cable to the serial port connector on the alarm panel module of the JCS1200 platform.
3. Connect the each of the RJ-45 connectors on the cable to your console.



NOTE: Some consoles require that you use a CPU adapter. If needed, connect a CPU adapter to each of the 12 RJ-45 connectors on the breakout cable. Then connect each CPU adapter to your console. For information about the CPU adapter pinouts, see the *JCS1200 Control System Hardware Guide*.

## Step 6: Integrate an Offline T Series Core Router with the JCS1200 Platform

You can connect up to three of the following T Series Core routers running Junos OS Release 9.2 or later to the JCS1200 platform: T320 router, T640 routing node, and T1600

routing node. The following procedures describe connecting the JCS1200 platform to a T Series Core router:

- Replace the Standard CBs in the T Series Core Router on page 21
- Connect an Offline T Series Core Router to the JCS1200 Platform on page 21

## Replace the Standard CBs in the T Series Core Router

Before you connect an offline T Series Core router to the JCS1200 platform, you must replace the standard control boards (CBs) with T-CBs. To replace the CBs with T-CBs:

1. If the routing platform is powered on, issue the **request system halt both-routing-engines** operational mode command from the console or other management device connected to the routing platform. The command shuts down the Routing Engines cleanly, so their state information is preserved.

```
user@host> request system halt both-routing-engines
```

Wait until a message appears on the console confirming that the operating system has halted. For more information about the command, see the *Junos OS System Basics and Services Command Reference*.

2. Attach an electrostatic discharge (ESD) grounding strap to your bare wrist, and connect the strap to one of the ESD points on the chassis.
3. Switch both circuit breakers on each power supply faceplate to the off position (O).



**NOTE:** The CBs and T-CBs are hot-removable and hot-insertable if the routing node contains redundant host subsystems. However, we recommend that you power off the routing platform before you replace the CBs and T-CBs.

4. Set the switches on each T-CB:
  - Set the chassis ID switch to 0. You must use the same chassis ID on each T-CB.
  - Set the **M/S** switch on the T-CB faceplate to **S**.
5. Replace each CB with a T-CB. Use the standard replacement procedure described in the hardware guide for your routing platform.
6. You can optionally upgrade the Routing Engines in the routing platform. To replace each Routing Engine, follow the standard replacement procedure described in the hardware guide for your routing platform.

## Connect an Offline T Series Core Router to the JCS1200 Platform

After you replace the CBs with T-CBs, you connect each T-CB on the T Series Core router to each switch module on the JCS1200 platform. Figure 10 on page 22 shows the location of the switch modules on the JCS1200 platform.

Figure 10: Location of Switch Modules on the JCS1200 Platform

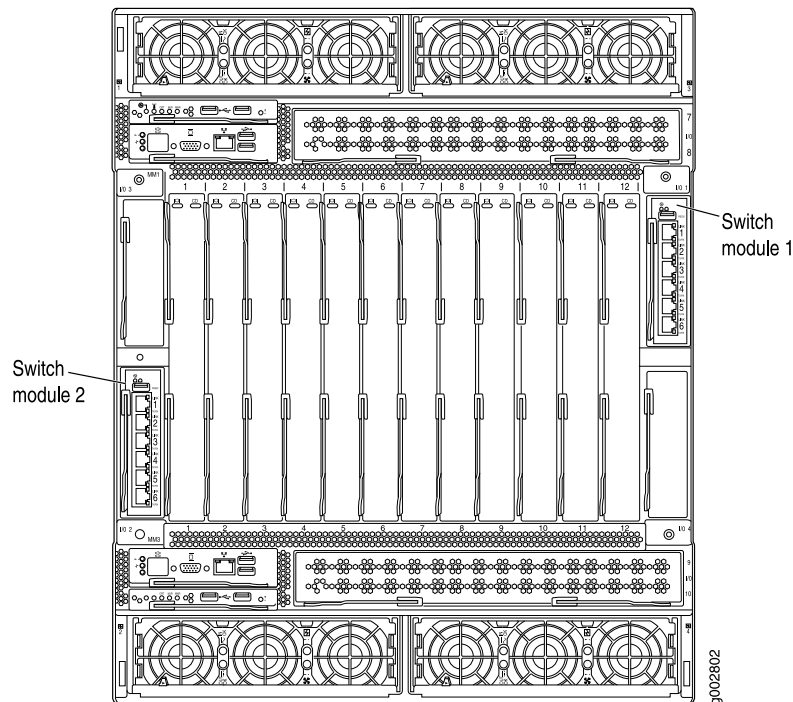

To connect the T-CBs (see Figure 11 on page 23):

1. Attach an electrostatic discharge (ESD) grounding strap to your bare wrist, and connect the strap to one of the ESD points on the chassis.
2. Plug an Ethernet adapter (**ETH**) into the top RJ-45 port (labeled 1) of switch module 1 on the JCS1200 platform.
3. Connect one end of a UTP Category 5 cable to the Ethernet adapter.
4. Plug the other end of the cable into the port labeled **CIP** on **T-CB-0**. Dress the cable appropriately.



**NOTE:** The RJ-45 port labeled **AUX** on a T-CB is reserved for future use.

5. If you installed a redundant switch module into switch module bay 2:
  - a. Plug an **ETH** adapter into the top RJ-45 port (labeled 1) of switch module 2 on the JCS1200 platform.
  - b. Connect one end of a UTP Category 5 cable to the Ethernet adapter.
  - c. Plug the other end of the cable into the port labeled **CIP** on **T-CB-1**. Dress the cable appropriately.

Figure 11: Connect the JCS1200 Platform to a T Series Core Router

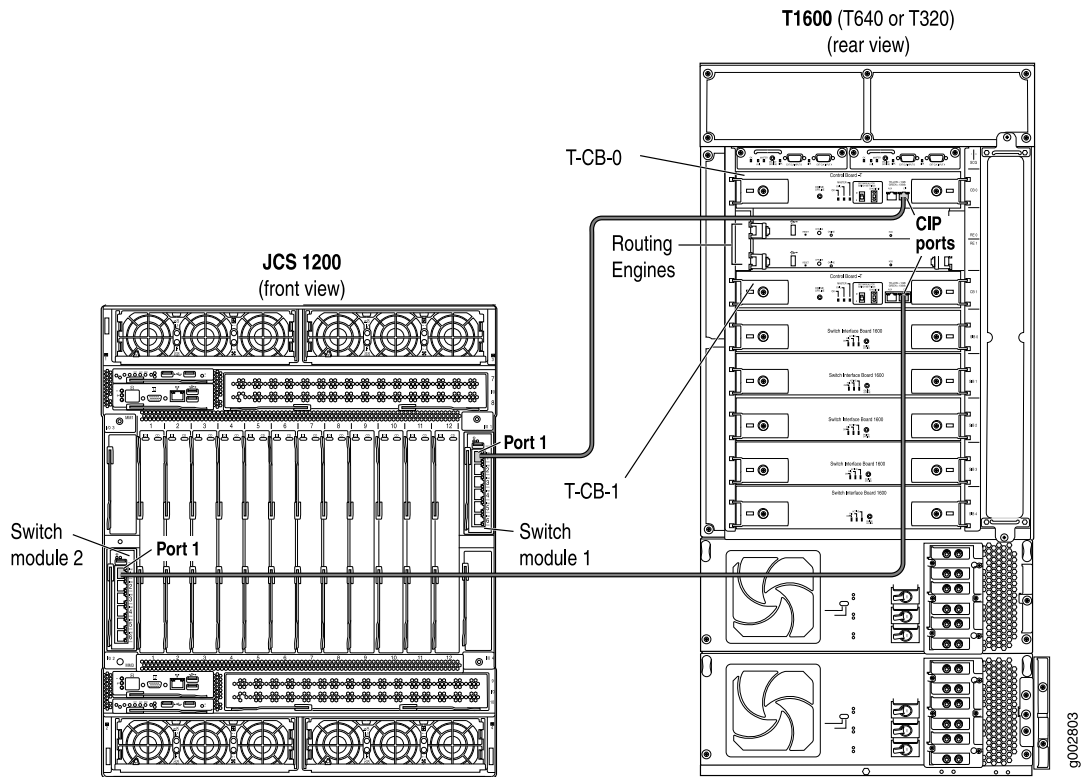

NOTE: Six ports are identified as EXT1, EXT2, EXT3, EXT4, EXT5, and EXT6 in the switch configuration menus and are labeled 1 through 6 (from top to bottom) on the switch module. The ports labeled 4 and 5 on the switch module are reserved for future use. Port 6 connects to the management ports on all the Routing Engines in the JCS chassis.

- The copper model of the Gigabit Ethernet switch module has six external copper 1000BASE-T Ethernet ports. You can use RJ-45 ports labeled 1 through 3 to connect up to three T Series routers running Junos OS Release 9.2 and later to the JCS1200 platform.
- The fiber model of the Gigabit Ethernet switch module has six external 1000BASE-LX SFP transceiver ports. (For interface specifications, see Gigabit Ethernet 1000BASE-LX Interface Specifications.) You can use the SFP ports labeled 1 through 3 to connect over the network to route reflector applications.



NOTE: The connections between the switch modules and the T-CBs are proprietary Ethernet connections. Do not attempt to connect these components through a switch or hub.

## Step 7: Power On the T Series Core Router

---

After you have connected the control planes between the T Series Core router and the JCS1200 platform, power on the routing platform, monitor the boot process, and verify the connections. Follow this procedure:

1. Attach an electrostatic discharge (ESD) grounding strap to your bare wrist, and connect the strap to one of the ESD points on the chassis.
2. Switch the circuit breakers on one of the power supplies to the on position (I) and observe the LEDs on the power supply faceplate. If the power supply is correctly installed and is functioning properly, the **DC OK** LED lights steadily, and the **CB ON** LED blinks momentarily, then lights steadily.



NOTE: After powering off a power supply, wait at least 60 seconds before powering it back on. After powering on a power supply, wait at least 60 seconds before powering it off.

If the system is completely powered off when you power on the power supply, the Routing Engine boots as the power supply completes its startup sequence. If the Routing Engine finishes booting and you need to power off the system again, first issue the CLI request system halt command.

After a power supply is powered on, it can take up to 60 seconds for status indicators—such as the output status LEDs on the power supply, the show chassis command display, and messages on the LCD on the craft interface—to indicate that the power supply is functioning normally. Ignore error indicators that appear during the first 60 seconds.

3. Repeat Step 2 for the remaining power supply.
4. On an external management device connected to the console or auxiliary port of the CIP, monitor the startup process to verify that the system has booted properly.



NOTE: You do not need to reboot the JCS1200 platform after the routing platform has booted.

## Step 8: Configure the Software for the JCS1200 Platform

---

The JCS1200 platform ships with one preconfigured management module but you can install and configure a second management module for redundancy. The Routing Engines are preconfigured with Junos OS. Perform general configuration of the JCS1200 platform and installed components through the management module. See the *Junos OS Protected System Domain Configuration Guide* for information and instructions. Some components

in the JCS1200 platform, such as management modules and Routing Engines, might also require additional configuration:

- Configure the JCS1200 Management Module on page 25
- Configure the JCS1200 Routing Engines on page 25

## Configure the JCS1200 Management Module

All management modules are preconfigured with the same static IP address. You can use the management module user interface to assign a new static IP address. To establish connectivity, the management module attempts to use Dynamic Host Configuration Protocol (DHCP) to acquire its initial IP address for the management module Ethernet port. If DHCP is not installed or is enabled and fails, the management module uses the static IP address. Use the management module to configure other JCS1200 component settings, such as user accounts, DHCP, or wake on LAN. For information about configuring the management module, see the *Junos OS Protected System Domain Configuration Guide*.

## Configure the JCS1200 Routing Engines

To achieve Routing Engine redundancy, you must configure the Ethernet controllers in one or more Routing Engines for failover. When failover occurs on a Routing Engine, the secondary Ethernet controller takes over network communications, using the JCS1200 switch module that is associated with that controller. Install a pair of JCS1200 switch modules in switch module bays 1 and 2, and then configure them and your network infrastructure so that they can direct traffic to the same destinations. For information about configuring the Routing Engines, see the *Junos OS Protected System Domain Configuration Guide*.

## Safety Warnings



.....

WARNING: See installation instructions before connecting the platform. This is a summary of safety warnings. For a complete list of warnings for this platform, including translations, see the *JCS1200 Control System Hardware Guide* at <http://www.juniper.net/techpubs/hardware/>.

.....



.....

WARNING: The intrabuilding port(s) of the router is suitable for connection to intrabuilding or unexposed wiring or cabling only. The intrabuilding port(s) of the router **MUST NOT** be metallically connected to interfaces that connect to the OSP or its wiring. These interfaces are designed for use as intrabuilding interfaces only (Type 2 or Type 4 ports as described in GR-1089-CORE, Issue 4) and require isolation from the exposed OSP cabling. The addition of primary protectors is not sufficient protection to connect these interfaces metallically to OSP wiring.

.....



CAUTION: Before removing or installing components of a router, attach an ESD strap to an ESD point and place the other end of the strap around your bare wrist. Failure to use an ESD strap could result in damage to the platform.

---

- Only trained and qualified personnel should install or replace the platform.
- Perform only the procedures described in this Quick Start or the *JCS1200 Control System Hardware Guide*. Other services should be performed by authorized service personnel only.
- Read the installation instructions before you connect the platform to a power source.
- Before installing the platform, read the guidelines for site preparation in the *JCS1200 Control System Hardware Guide* to make sure that the site meets power, environmental, and clearance requirements for the platform.
- When installing the platform, do not use a ramp inclined more than 10 degrees.
- Manually installing the platform requires four people to lift. Before lifting the chassis, remove components and attach the installation handle as described in the *JCS1200 Control System Hardware Guide*. To prevent injury, keep your back straight and lift with your legs, not your back.
- Mount the platform at the bottom of the rack if it is the only unit in the rack.
- When mounting the platform in a partially filled rack, load the rack from the bottom to the top, with the heaviest component at the bottom of the rack.
- If the rack is provided with stabilizing devices, install the stabilizers before mounting or servicing the platform in the rack.
- When removing or installing an electrical component, always place it component-side up on a flat antistatic surface or in an electrostatic bag.
- When you install the platform, always make the ground connection first and disconnect it last.
- Wire the DC power supply using the appropriate lugs. When connecting power, the proper wiring sequence is ground to ground, +RTN to +RTN, then –48 V to –48 V. When disconnecting power, the proper wiring sequence is –48 V to –48 V, +RTN to +RTN, then ground to ground. Always connect the ground wire first and disconnect it last.
- Do not work on the system or connect or disconnect cables during electrical storms.
- Before working on equipment that is connected to power lines, remove jewelry, including rings, necklaces, and watches. Metal objects heat up when connected to power and ground and can cause serious burns or become welded to the terminals.
- Failure to observe these safety warnings can result in serious physical injury.



WARNING: Electrical current from power, telephone, and communication cables is hazardous.

To avoid a shock hazard:

- Do not connect or disconnect any cables or perform installation, maintenance, or reconfiguration of this product during an electrical storm.
- Connect all power cords to a properly wired and grounded power source.
- Connect to properly wired power sources any equipment that will be attached to this product.
- When possible, use one hand only to connect or disconnect signal cables.
- Never power on any equipment when there is evidence of fire, water, or structural damage.
- Disconnect the attached AC power cords, DC power sources, network connections, telecommunications systems, and serial cables before you open the component covers, unless you are instructed otherwise in the installation and configuration procedures.
- Connect and disconnect cables as described in the following procedures when you install, move, or open covers on this product or attached components.

To connect power sources:

1. Turn OFF all power sources and equipment that are to be attached to this product.
2. Attach signal cables to the product.
3. Attach power cords to product.
  - For AC systems, use appliance inlets.
  - For DC systems, ensure correct polarity of  $-48$  V DC connections: RTN is + and  $-48$  V DC is -. Earth ground should use a two-hole lug for safety.
4. Attach signal cables to other components.
5. Connect power cords to their sources.
6. Turn ON all the power sources.

To disconnect power sources:

1. Turn OFF all power sources and equipment that are attached to this product.
  - For AC systems, remove all power cords from the chassis power receptacles for interrupt power at the AC power distribution unit.

- For DC systems, disconnect DC power sources at the breaker panel or by turning off the power source. Then remove the DC cables.
2. Remove signal cables from connectors.
  3. Remove all cables from components.



WARNING:

When installing laser products (such as fiber-optic devices or transmitters), note the following:

- Do not remove the covers. Removing the covers of the laser product could result in exposure to hazardous laser radiation. There are no serviceable parts inside the component.
- Use of controls or adjustments or performance of procedures other than those specified here might result in hazardous radiation exposure.



WARNING: Some laser products contain an embedded Class 3A or Class 3B laser diode. Note the following:

There is laser radiation when open. Do not stare into the beam, do not view directly with optical instruments, and avoid direct exposure to the beam.



CAUTION: The power control button on the component and the power switch on the power supply do not turn off the electrical current supplied to the component. The component also might have more than one power cord. To remove all electrical current from the component, disconnect all power cords from the power source.

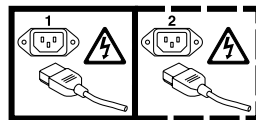

CAUTION: Hazardous energy is present when the Routing Engine is connected to the power source. Always replace the Routing Engine cover before installing the Routing Engine.



WARNING: Handling the cord on this product or cords associated with accessories sold with this product, will expose you to lead, a chemical known

to the State of California to cause cancer, and birth defects or other reproductive harm. Wash hands after handling.

**ADVERTENCIA:** El contacto con el cable de este producto o con cables de accesorios que se venden junto con este producto, pueden exponerle al plomo, un elemento químico que en el estado de California de los Estados Unidos está considerado como un causante de cáncer y de defectos congénitos, además de otros riesgos reproductivos. Lave las manos después de usar el producto.

---

## Compliance Statements for NEBS for JCS1200 Platforms

- The equipment is suitable for installation as part of the Common Bonding Network (CBN).
- The equipment is suitable for installation in locations where the National Electrical Code (NEC) applies.
- The battery return connection is to be treated as an isolated DC return (i.e. DC-I), as defined in GR-1089-CORE.

---

## Compliance Statements for EMC Requirements for the JCS1200 Platform

- Australia and New Zealand on page 29
- Canada on page 29
- China on page 30
- European Community on page 30
- Declaration of Conformity on page 30
- Japan on page 31
- Taiwan on page 32
- United Kingdom on page 32
- United States on page 32

### Australia and New Zealand



**CAUTION:** This is a Class A product. In a domestic environment this product may cause radio interference, in which case the user may be required to take adequate measures.

### Canada

This Class A digital apparatus complies with Canadian ICES-003.

Cet appareil numérique de la classe A est conforme à la norme NMB-003 du Canada.

## China

### 声 明

此为 A 级产品。在生活环境中，该产品可能会造成无线电干扰。在这种情况下，可能需要用户对其干扰采取切实可行的措施。

## European Community

This product is in conformity with the protection requirements of EU Council Directive 89/336/EEC on the approximation of the laws of the Member States relating to electromagnetic compatibility. Juniper Networks cannot accept responsibility for any failure to satisfy the protection requirements resulting from a nonrecommended modification of the product, including the fitting of non-Juniper Networks option cards.

This product has been tested and found to comply with the limits for Class A Information Technology Equipment according to CISPR 22/European Standard EN 55022. The limits for Class A equipment were derived for commercial and industrial environments to provide reasonable protection against interference with licensed communication equipment.



.....  
**CAUTION:** This is a Class A product. In a domestic environment this product may cause radio interference in which case the user may be required to take adequate measures.  
.....

## Declaration of Conformity

Figure 12 on page 31 shows the Declaration of Conformity for the router.

Figure 12: JCS1200 Declaration of Conformity



**Declaration of Conformity**

Juniper Networks, Inc.  
10 Technology Park Drive  
Westford, MA 01886 USA

declares that under our sole responsibility the product(s)

**Control System  
Model JCS1200**

is in conformity with the provisions of the following EC Directives, including all amendments, and  
with national legislation implementing these directives:

**Low Voltage Directive 2006/95/EEC  
EMC Directive 2004/108/EEC**

and that the following harmonized standards have been applied

EN 60950-1:2001+A11  
EN 60825-1:1994+A1+A2  
EN 55024:1998 +A1 + A2  
EN 61000-3-2: (2000) + A2 EN 61000-3-3:1995 +A1  
EN 55022: (2006) Class A

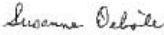
Place Westford, MA	 Signature Susanne Delisle	Date 04/07/2008
-----------------------	---	--------------------

## Japan

この装置は、クラス A 情報技術装置です。この装置を家庭環境で使用すると電波妨害を引き起こすことがあります。この場合には使用者が適切な対策を講ずるよう要求されることがあります。 VCCI-A

Translation from Japanese—This is a Class A product. In a domestic environment this product may cause radio interference in which case the user may be required to take adequate measures. VCCI-A

## Taiwan

警告使用者：  
這是甲類的資訊產品，在  
居住的環境中使用時，可  
能會造成射頻干擾，在這  
種情況下，使用者會被要  
求採取某些適當的對策。

## United Kingdom

This apparatus is approved under approval number NS/G/1234/J/100003 for indirect connection to public telecommunication systems in the United Kingdom.

## United States

This equipment has been tested and found to comply with the limits for a Class A digital device, pursuant to Part 15 of the FCC Rules. These limits are designed to provide reasonable protection against harmful interference when the equipment is operated in a commercial environment. This equipment generates, uses, and can radiate radio frequency energy and, if not installed and used in accordance with the instruction manual, may cause harmful interference to radio communications. Operation of this equipment in a residential area is likely to cause harmful interference, in which case the user will be required to correct the interference at his own expense.

Properly shielded and grounded cables and connectors must be used in order to meet FCC emission limits. Juniper Networks is not responsible for any radio or television interference caused by using other than recommended cables and connectors or by unauthorized changes or modifications to this equipment. Unauthorized changes or modifications could void the user's authority to operate the equipment.

This device complies with Part 15 of the FCC Rules. Operation is subject to the following two conditions: (1) this device may not cause harmful interference, and (2) this device must accept any interference received, including interference that may cause undesired operation.

---

## Junos Documentation and Release Notes

For a list of related Junos documentation, see <http://www.juniper.net/techpubs/software/junos/>.

If the information in the latest release notes differs from the information in the documentation, follow the *Junos Release Notes*.

To obtain the most current version of all Juniper Networks® technical documentation, see the product documentation page on the Juniper Networks website at <http://www.juniper.net/techpubs/>.

## Requesting Technical Support

---

Technical product support is available through the Juniper Networks Technical Assistance Center (JTAC). If you are a customer with an active J-Care or JNASC support contract, or are covered under warranty, and need postsales technical support, you can access our tools and resources online or open a case with JTAC.

- JTAC policies—For a complete understanding of our JTAC procedures and policies, review the JTAC User Guide located at <http://www.juniper.net/us/en/local/pdf/resource-guides/7100059-en.pdf> .
- Product warranties—For product warranty information, visit <http://www.juniper.net/support/warranty/> .
- JTAC Hours of Operation —The JTAC centers have resources available 24 hours a day, 7 days a week, 365 days a year.

## Self-Help Online Tools and Resources

For quick and easy problem resolution, Juniper Networks has designed an online self-service portal called the Customer Support Center (CSC) that provides you with the following features:

- Find CSC offerings: <http://www.juniper.net/customers/support/>
- Find product documentation: <http://www.juniper.net/techpubs/>
- Find solutions and answer questions using our Knowledge Base: <http://kb.juniper.net/>
- Download the latest versions of software and review release notes: <http://www.juniper.net/customers/csc/software/>
- Search technical bulletins for relevant hardware and software notifications: <https://www.juniper.net/alerts/>
- Join and participate in the Juniper Networks Community Forum: <http://www.juniper.net/company/communities/>
- Open a case online in the CSC Case Management tool: <http://www.juniper.net/cm/>

To verify service entitlement by product serial number, use our Serial Number Entitlement (SNE) Tool: <https://tools.juniper.net/SerialNumberEntitlementSearch/>

## Opening a Case with JTAC

You can open a case with JTAC on the Web or by telephone.

- Use the Case Management tool in the CSC at <http://www.juniper.net/cm/> .
- Call 1-888-314-JTAC (1-888-314-5822 toll-free in the USA, Canada, and Mexico).

For international or direct-dial options in countries without toll-free numbers, visit us at <http://www.juniper.net/support/requesting-support.html>

## Revision History

---

June 2010—530-035420. Added information about connecting multiple T Series Core routers running Junos OS Release 9.2 or later. Added information about the fiber-optic switch module.

18 April 2008—530-023227-01. Revision 1.

Copyright © 2010, Juniper Networks, Inc. All rights reserved.

Juniper Networks, Junos, Steel-Belted Radius, NetScreen, and ScreenOS are registered trademarks of Juniper Networks, Inc. in the United States and other countries. The Juniper Networks Logo, the Junos logo, and JunosE are trademarks of Juniper Networks, Inc. All other trademarks, service marks, registered trademarks, or registered service marks are the property of their respective owners.

Juniper Networks assumes no responsibility for any inaccuracies in this document. Juniper Networks reserves the right to change, modify, transfer, or otherwise revise this publication without notice.

Products made or sold by Juniper Networks or components thereof might be covered by one or more of the following patents that are owned by or licensed to Juniper Networks: U.S. Patent Nos. 5,473,599, 5,905,725, 5,909,440, 6,192,051, 6,333,650, 6,359,479, 6,406,312, 6,429,706, 6,459,579, 6,493,347, 6,538,518, 6,538,899, 6,552,918, 6,567,902, 6,578,186, and 6,590,785.