

Configuring Relative Strict-Priority Scheduling for Aggregate Shaping Rates

To configure relative strict priority scheduling for aggregate shaping rates:

1. Create a scheduler profile for the strict-priority queue.

```
host1(config)# scheduler-profile relativeStrict
host1(config-scheduler-profile)# shaping-rate 500000
host1(config-scheduler-profile)# weight 0
host1(config-scheduler-profile)# exit
```

Configuring the weight of 0 reduces latency and jitter.

2. Create a scheduler profile for the nonstrict best-effort queue.

```
host1(config)# scheduler-profile be
host1(config-scheduler-profile)# shaping-rate 1000000 burst 1
host1(config-scheduler-profile)# weight 8
host1(config-scheduler-profile)# exit
```



TIP: If you need to impose a shaping rate on the nonstrict queues to meet a functional requirement, you can specify a rate less than the aggregate rate. The key is that the burst size must be one, or small. The burst size determines the maximum-sized packet that can squeeze in front of a relative strict-priority packet in the round robin.

3. Create a scheduler profile for the aggregate bandwidth.

```
host1(config)# scheduler-profile vcAggregate
host1(config-scheduler-profile)# shaping-rate 1000000
host1(config-scheduler-profile)# exit
```

4. Create a QoS profile, configure node shaping for each queue, and add each of the queues to the QoS profile.

```
host1(config)# qos-profile relative-strict-aggregate
host1(config-qos-profile)# atm-vc node scheduler-profile vcAggregate
host1(config-qos-profile)# atm-vc queue traffic-class best-effort
scheduler-profile be
host1(config-qos-profile)# atm-vc queue traffic-class voice scheduler-profile
relativeStrict
host1(config-qos-profile)# exit
host1(config)#
```

This configuration creates the hierarchy shown in Figure 1.

Figure 1: Sample Relative Strict-Priority Scheduler Hierarchy

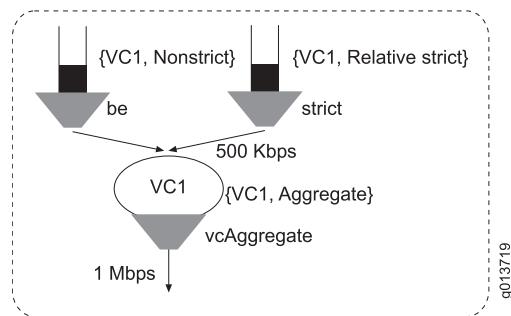

- Related Topics**
- Strict-Priority and Relative Strict-Priority Scheduling Overview
 - For more information about specifying an expression that you can reference within a scheduler profile, see Using Expressions for Bandwidth and Burst Values in a Scheduler Profile
 - node
 - qos-profile
 - scheduler-profile
 - shaping-rate
 - weight

Published: 2009-10-07