

Example: QoS Parameter Configuration for Controlling Subscriber Bandwidth

The example in this section illustrates how to use parameters to control the minimum and maximum bandwidth of a subscriber. The example includes procedures for both QoS administrators and QoS clients.

Through QoS parameter definitions, the QoS administrator defines a QoS scheduler hierarchy that corresponds to the physical network topology shown in Figure 1.

Figure 1: Physical Network Topology

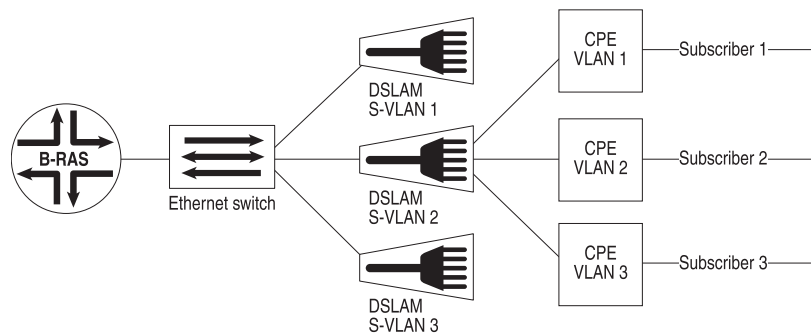

The S-VLAN scheduler nodes correspond to the DSLAM in the physical network topology; the VLAN scheduler nodes correspond to the subscribers.

Figure 2 shows the QoS scheduler hierarchy that the QoS client creates when configuring a different service for each subscriber.

Figure 2: QoS Scheduler Hierarchy

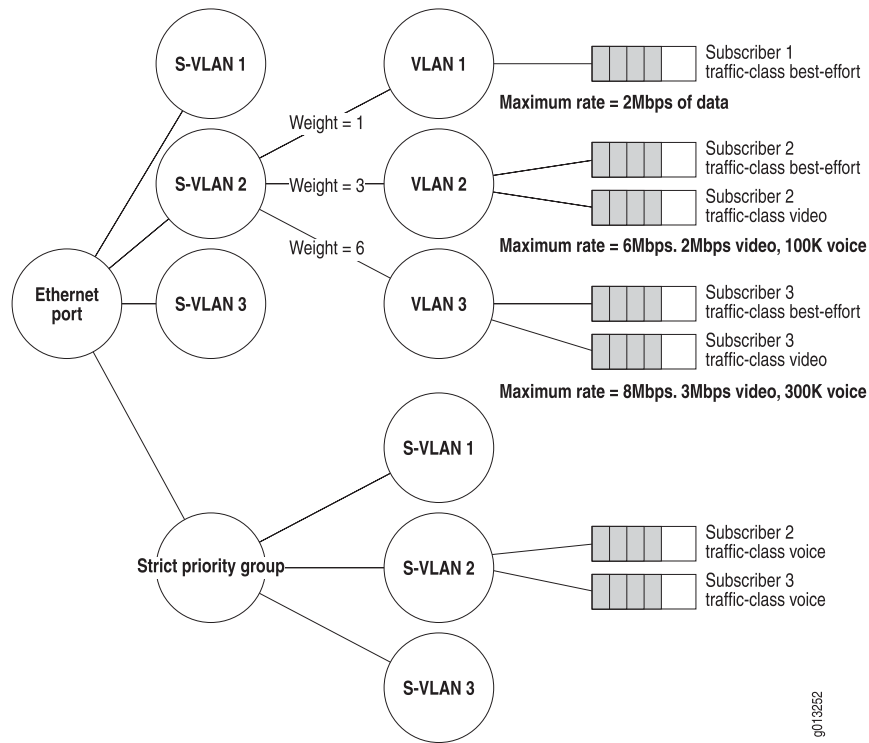

For Subscriber 1, the QoS client configures a basic best-effort data service, with a maximum rate of 2 Mbps, and assigns a scheduler weight value of 1.

For Subscriber 2, the QoS client configures a basic triple-play service consisting of voice, video, and best-effort data services. This service enables the subscriber to transmit up to 6 Mbps of combined voice, video, and best-effort data traffic. The service limits video traffic to 2 Mbps and enables low-latency bandwidth for one 100 Kbps voice call. The QoS client then assigns this subscriber a scheduler weight value of 3, enabling this subscriber to claim up to three times the bandwidth than the basic data service configured for Subscriber 1.

For Subscriber 3, the QoS client configures an enhanced triple-play service consisting of voice, video and best-effort data services. This enhanced triple-play service enables the subscriber to transmit up to 8 Mbps of combined voice, video, and best-effort data traffic. This service limits video traffic to 3 Mbps and enables low-latency bandwidth for up to three 100 Kbps voice calls. The QoS client then assigns this subscriber a scheduler weight value of 6, enabling this subscriber to claim up to six times the bandwidth of the basic data service subscriber configured for Subscriber 1, and up to twice the bandwidth of the basic triple-play subscriber configured for Subscriber 2.

Procedure for QoS Administrators

This section describes the procedures to configure the scheduler hierarchy shown in Figure 2 by using QoS parameters.

Configuring Traffic Classes and Traffic Class Groups

The QoS administrator configures traffic classes and traffic-class groups for best-effort data, video, and voice services.

1. Configure the traffic classes.
 - a. Configure the traffic class named best-effort.
 - b. Configure the traffic class named video.
 - c. Configure the traffic class named voice.
 - d. Enable the voice traffic class to provide a strict priority treatment throughout the fabric.

```
host1(config)#traffic-class best-effort  
host1(config-traffic-class)#exit
```

```
host1(config)#traffic-class video  
host1(config-traffic-class)#exit
```

```
host1(config)#traffic-class voice  
host1(config-traffic-class)#fabric-strict-priority  
host1(config-traffic-class)#exit
```

2. Configure a traffic-class group for low-latency expedited forwarding (EF) and add the voice traffic class into the traffic-class group EF.
 - a. Configure the EF traffic-class group with strict-priority scheduling.
 - b. Add the voice traffic class to the traffic-class group.

```
host1(config)#traffic-class-group EF auto-strict-priority  
host1(config-traffic-class-group)#traffic-class voice  
host1(config-traffic-class-group)#exit
```

The remaining traffic classes, best-effort and video, remain in the default traffic-class group.

Configuring the Parameter Definitions

After configuring the traffic classes and traffic-class groups, the QoS administrator configures the parameter definitions for Subscribers 1, 2, and 3.

1. Configure a parameter definition for the maximum subscriber bandwidth.
 - a. Configure the parameter definition named max-subscriber-bandwidth.
 - b. Enable the parameter to control VLANs.
 - c. Enable the parameter to have instances created on VLAN subinterfaces.
 - d. Specify the valid range of this parameter as 512 Kbps–8 Mbps.

```
host1(config)#qos-parameter-define max-subscriber-bandwidth  
host1(config-qos-parameter-define)#controlled-interface-type vlan  
host1(config-qos-parameter-define)#instance-interface-type vlan  
host1(config-qos-parameter-define)#range 512000 8192000  
host1(config-qos-parameter-define)#exit
```

2. Configure a parameter definition for a subscriber's weight in the hierarchical round-robin (HRR) scheduler. This parameter is used to provide different scheduler weights for each of the three service offerings.
 - a. Configure the parameter definition named subscriber-weight.
 - b. Enable the parameter to control VLANs.
 - c. Enable the parameter to have instances created on VLAN subinterfaces.
 - d. Specify the valid range of this parameter as 1–6.

```

host1(config)#qos-parameter-define subscriber-weight
host1(config-qos-parameter-define)#controlled-interface-type vlan
host1(config-qos-parameter-define)#instance-interface-type vlan
host1(config-qos-parameter-define)#range 1 6
host1(config-qos-parameter-define)#exit

```

3. Configure a parameter definition for the subscriber's maximum video bandwidth. By creating a parameter instance on S-VLANs, the QoS administrator can specify a subscriber's maximum video bandwidth for each DSLAM in the hierarchy.
 - a. Configure the parameter definition named max-subscriber-video-bandwidth.
 - b. Enable the parameter to control VLANs.
 - c. Enable the parameter to have instances created on both SVLAN and VLAN subinterfaces.
 - d. Specify the valid range of this parameter as 1 Mbps–5 Mbps.

```

host1(config)#qos-parameter-define max-subscriber-video-bandwidth
host1(config-qos-parameter-define)#controlled-interface-type vlan
host1(config-qos-parameter-define)#instance-interface-type vlan
host1(config-qos-parameter-define)#instance-interface-type svlan
host1(config-qos-parameter-define)#range 1000000 5000000
host1(config-qos-parameter-define)#exit

```

4. Configure a parameter definition for the maximum number of 100 Kbps voice calls supported for the subscriber.
 - a. Configure the parameter definition named max-100Kbps-voice-calls.
 - b. Enable the parameter to control VLANs.
 - c. Enable the parameter to have instances created on VLAN subinterfaces.
 - d. Specify the valid range of this parameter as 1–3.

```

host1(config)#qos-parameter-define max-100Kbps-voice-calls
host1(config-qos-parameter-define)#controlled-interface-type vlan
host1(config-qos-parameter-define)#instance-interface-type vlan
host1(config-qos-parameter-define)#range 1 3
host1(config-qos-parameter-define)#exit

```

Configuring the Scheduler Profiles

The QoS administrator can then reference the parameter definitions within a scheduler profile, which defines the shaping rates for the parameter.

1. Configure a scheduler profile to specify the maximum bandwidth of the subscriber's best-effort data.
 - a. Configure the scheduler profile named subscriber-best-effort.
 - b. Configure the shared-shaping rate by referencing the max-subscriber-bandwidth parameter and choosing automatic shared shaping.

```
host1(config)#scheduler-profile subscriber-best-effort  
host1(config-scheduler-profile)#shared-shaping-rate max-subscriber-bandwidth  
auto  
host1(config-scheduler-profile)#exit
```

2. Configure a scheduler profile to specify the maximum bandwidth of the subscriber's video service.
 - a. Configure the scheduler profile named subscriber-video.
 - b. Configure the shaping rate by referencing the max-subscriber-video-bandwidth parameter.

```
host1(config)#scheduler-profile subscriber-video  
host1(config-scheduler-profile)#shaping-rate max-subscriber-video-bandwidth  
host1(config-scheduler-profile)#exit
```

3. Configure a scheduler profile for the subscriber's weight within the HRR scheduler.
 - a. Configure the scheduler profile named subscriber-weight.
 - b. Configure the weight using the default for the subscriber-weight parameter.

```
host1(config)#scheduler-profile subscriber-weight  
host1(config-scheduler-profile)#weight subscriber-weight  
host1(config-scheduler-profile)#exit
```

4. Configure a scheduler profile for the subscriber's voice service.
 - a. Configure the scheduler profile named subscriber-voice.
 - b. Configure the shaping rate by referencing the max-100Kbps-voice-calls parameter and multiplying it by 100 Kbps of voice calls.

```
host1(config)#scheduler-profile subscriber-voice  
host1(config-scheduler-profile)#shaping-rate max-100Kbps-voice-calls *  
100000  
host1(config-scheduler-profile)#exit
```

Configuring the QoS Profiles

By referencing the scheduler profiles within QoS profiles, the QoS administrator creates the scheduler hierarchy. In this portion of the example, the QoS administrator configures QoS profiles for the best-effort data and triple-play service offerings.

1. Define a QoS profile for the best-effort data service.

- a. Create the QoS profile named subscriber-data-service.
- b. Create a node for S-VLAN subinterfaces.
- c. Specify a node for VLAN subinterfaces and reference the subscriber-weight scheduler profile.
- d. Specify a queue for VLAN subinterfaces, referencing the best-effort traffic class and the subscriber-best-effort scheduler-profile.

```

host1(config)#qos-profile subscriber-data-service
host1(config-qos-profile)#svlan node
host1(config-qos-profile)#vlan node scheduler-profile subscriber-weight
host1(config-qos-profile)#vlan queue traffic-class best-effort scheduler-profile
subscriber-best-effort
host1(config-qos-profile)#exit

```

The best-effort queue rule for VLAN subinterfaces refers to the subscriber-best-effort scheduler profile. The scheduler profile refers to the max-subscriber-bandwidth parameter that controls the maximum rate of this subscriber's best-effort queue.

2. Define a QoS profile for the triple-play service and specify S-VLAN nodes and VLAN nodes.
 - a. Create a QoS profile named subscriber-triple-play.
 - b. Specify a node for S-VLAN subinterfaces.
 - c. Specify a node for VLAN subinterfaces and reference the subscriber-weight scheduler profile.
 - d. Specify a node for S-VLAN subinterfaces and reference the EF traffic-class group.
 - e. Specify a queue for VLAN subinterfaces, referencing the best-effort traffic class and the subscriber-best-effort scheduler profile.
 - f. Specify a queue for VLAN subinterfaces, referencing the video traffic class and the subscriber-video scheduler profile.
 - g. Specify a queue for VLAN subinterfaces, referencing the voice traffic-class and the subscriber-voice scheduler profile.

```

host1(config)#qos-profile subscriber-triple-play
host1(config-qos-profile)#svlan node
host1(config-qos-profile)#vlan node scheduler-profile subscriber-weight
host1(config-qos-profile)#svlan node group EF
host1(config-qos-profile)#vlan queue traffic-class best-effort scheduler-profile
subscriber-best-effort
host1(config-qos-profile)#vlan queue traffic-class video scheduler-profile
subscriber-video
host1(config-qos-profile)#vlan queue traffic-class voice scheduler-profile
subscriber-voice
host1(config-qos-profile)#exit

```

VLAN queues are used for each service. The VLAN queue rules reference scheduler profiles that define the scheduler rates for the service.

3. Configure a QoS profile and attach to all Fast Ethernet, Gigabit Ethernet, and 10-Gigabit Ethernet interfaces in the chassis.
 - a. Create a QoS profile named ethernet-default.
 - b. Remove the QoS profile rule for creating IP nodes.
 - c. Remove the IP queue for the best-effort traffic-class.

```
host1(config)#qos-profile ethernet-default
host1(config-qos-profile)#no ip node
host1(config-qos-profile)#no ip queue traffic-class best-effort
host1(config-qos-profile)#exit
```

4. Configure the Fast Ethernet interface and VLAN subinterfaces.
 - a. Configure the Fast Ethernet interface in slot 9, port 0.
 - b. Configure the VLAN major interface.
 - c. Configure the VLAN subinterface at slot 9, port 0, subinterface 1.
 - d. Assign an S-VLAN ID of 2 and a VLAN ID of 1 to the VLAN subinterface.
 - e. Assign an IP address to the VLAN subinterface.
 - f. Repeat Steps a–e to configure VLAN subinterfaces in slot 9, port 0, subinterface 2 and in slot 9, port 0, subinterface 3.

```
host1(config)# interface fastEthernet 9/0
host1(config-if)#encapsulation vlan
host1(config-if)#exit
host1(config)#interface fastEthernet 9/0.1
host1(config-subif)#svlan id 2 1
host1(config-subif)#ip address 192.1.1.1 255.255.255.0
host1(config)#interface fastEthernet 9/0.2
host1(config-subif)#svlan id 2 2
host1(config-subif)#ip address 192.2.1.1 255.255.255.0
host1(config-subif)#exit
host1(config)#interface fastEthernet 9/0.3
host1(config-subif)#svlan id 2 3
host1(config-subif)#ip address 192.3.1.1 255.255.255.0
host1(config-subif)#exit
```

Procedure for QoS Clients

This section describes procedures to create parameter instances for Subscribers 1, 2, and 3.

Creating a Global Parameter Instance

The QoS client creates global parameter instances to provide a minimal level of default service for the router. In this portion of the example, the QoS client configures 2 Mbps of data traffic and configures a scheduler weight of 1 for Subscriber 1. For

Subscribers 2 and 3, the QoS client then configures a maximum of 2 Mbps of video bandwidth and 1 voice call.

To create a global parameter instance:

1. Create a global parameter instance for max-subscriber-bandwidth with a value of 2000000.
2. Create a global parameter instance for subscriber-weight with a value of 1.
3. Create a global parameter instance for subscriber-video-bandwidth with a value of 2000000.
4. Create a global parameter instance for max-100Kbps-voice-calls with a value of 1.

```
host1(config)#qos-parameter max-subscriber-bandwidth 2000000
host1(config)#qos-parameter subscriber-weight 1
host1(config)#qos-parameter max-subscriber-video-bandwidth 2000000
host1(config)#qos-parameter max-100Kbps-voice-calls 1
```

Creating a Global Parameter Instance for Individual DSLAMs

Instead of creating global parameter instances, the QoS client can create different parameter instances for the DSLAMs that correspond to the S-VLAN nodes shown in Figure 2. In this portion of the example, the QoS client creates 1 Mbps video streams by default on DSLAM 1, rather than the 2Mbps global parameter instance.

1. Specify the Fast Ethernet interface in slot 9, port 0.
2. Attach the QoS parameter max-subscriber-video-bandwidth to S-VLAN 1.

```
host1(config)#interface fastEthernet 9/0
host1(config-if)#svlan 1 qos-parameter max-subscriber-video-bandwidth 1000000
host1(config-if)#exit
```

Creating Parameter Instances for Subscribers

The QoS client creates a parameter instance for Subscribers 1, 2, and 3.

1. Configure the basic-data service for Subscriber 1.
 - a. Specify the Fast Ethernet interface in slot 9, port 0.
 - b. Attach the QoS profile subscriber-data-service to the subscriber's Fast Ethernet interface.

```
host1(config)#interface fastEthernet 9/0.1
host1(config-subif)#qos-profile subscriber-data-service
host1(config-subif)#exit
```

This QoS profile references the scheduler profiles, which then reference the parameter instances max-subscriber-bandwidth and subscriber-weight. These global parameter instances are created with values 2 Mbps and 1.

2. Configure a basic triple-play service consisting of voice, video, and data services for Subscriber 2.

- a. Specify the Fast Ethernet interface in slot 9, port 0.
- b. Create a parameter instance for max-subscriber-bandwidth, enabling the subscriber to transmit up to 6 Mbps of combined voice, video, and data traffic.
- c. Create a parameter instance for subscriber-weight with a value of 3. This value enables the subscriber to claim up to three times the bandwidth of Subscriber 1, with basic data service.
- d. Create a parameter instance for max-subscriber-video-bandwidth, limiting video traffic to 2 Mbps.
- e. Create a parameter instance for max-100Kbps-voice-calls, enabling bandwidth for one 100 Kbps voice call.
- f. Attach the QoS profile subscriber-triple-play to the subscriber's interface.

```

host1(config)#interface fastEthernet 9/0.2
host1(config-if)#qos-parameter max-subscriber-bandwidth 6000000
host1(config-if)#qos-parameter subscriber-weight 3
host1(config-if)#qos-parameter max-subscriber-video-bandwidth 2000000
host1(config-if)#qos-parameter max-100Kbps-voice-calls 1
host1(config-if)#qos-profile subscriber-triple-play
host1(config-if)#exit

```

3. Configure an enhanced triple-play service consisting of voice, video, and data services for Subscriber 3. Enable the subscriber to have twice as much bandwidth as Subscriber 2, with basic triple-play service.
 - a. Create a parameter instance for max-subscriber-bandwidth, enabling the subscriber to transmit up to 8 Mbps of combined voice, video, and data traffic.
 - b. Create a parameter instance for subscriber-weight with a value of 6, enabling the subscriber to claim up to six times the bandwidth of Subscriber 1, with basic data service.
 - c. Create a parameter instance for max-subscriber-video-bandwidth, limiting video traffic to 3 Mbps.
 - d. Create a parameter instance for max-100Kbps-voice-calls, enabling up to three 100 Kbps voice calls.
 - e. Attach the QoS profile subscriber-triple-play to the subscriber's interface.

```

host1(config)#interface fastEthernet 9/0.3
host1(config-if)#qos-parameter max-subscriber-bandwidth 8000000
host1(config-if)#qos-parameter subscriber-weight 6
host1(config-if)#qos-parameter max-subscriber-video-bandwidth 3000000
host1(config-if)#qos-parameter max-100Kbps-voice-calls 3
host1(config-if)#qos-profile subscriber-triple-play
host1(config-if)#exit

```

Monitoring the Subscriber Configuration

After completing the configuration, both the QoS administrator and the QoS client can monitor it by issuing **show** commands.

1. To display the traffic classes for best-effort, video, and voice, issue the **show traffic-class** command.

```
host1#show traffic-class
```

traffic class	fabric weight	fabric strict priority
best-effort	8	no
video	8	no
voice	8	yes

2. To display the traffic-class group EF, issue the **show traffic-class-group** command.

```
host1#show traffic-class-group
```

```
traffic-class-group EF auto-strict-priority
traffic-class voice
```

3. To display the settings for all four QoS parameter definitions (max-subscriber-bandwidth, subscriber-weight, max-subscriber-video-bandwidth, and max-100Kbps-voice-calls), issue the **show qos-parameter-define** command.

```
host1#show qos-parameter-define
```

parameter name	controlled interface types	instance interface types	subscriber interface types
max-subscriber-bandwidth	vlan	vlan	<none>
subscriber-weight	vlan	vlan	<none>
max-subscriber-video-bandwidth	vlan	vlan, svlan	<none>
max-100Kbps-voice-calls	vlan	vlan	<none>

parameter name	value range	properties
max-subscriber-bandwidth	512000 - 8192000	<none>
subscriber-weight	1 - 10	<none>
max-subscriber-video-bandwidth	1000000 - 5000000	<none>
max-100Kbps-voice-calls	1 - 3	<none>

4. To display the shaping rates and burst for the four scheduler profiles (subscriber-best-effort, subscriber-video, subscriber-weight, and subscriber-voice), issue the **show scheduler-profile** command.

```
host1#show scheduler-profile
```

scheduler	shaping rate	shaping burst
subscriber-best-effort
subscriber-video
subscriber-weight
subscriber-voice

```

-----
default                <none>    <none>
subscriber-best-effort <none>    <none>
subscriber-video       max-subscriber-video-bandwidth default
subscriber-weight      <none>    <none>
subscriber-voice       max-100Kbps-voice-calls * 100000 default
                        strict    assured
                        priority   rate
-----
scheduler              weight    -----
default                8        no      <none>
subscriber-best-effort 8        no      <none>
subscriber-video       8        no      <none>
subscriber-weight      subscriber-weight no      <none>
subscriber-voice       8        no      <none>
                        shared
                        shaping  shared
scheduler              shared shaping rate burst    shaping
-----
default                <none>    <none>    <none>
subscriber-best-effort max-subscriber-bandwidth default <none>
subscriber-video       <none>    <none>    <none>
subscriber-weight      <none>    <none>    <none>
subscriber-voice       <none>    <none>    <none>
                        shared
                        shaping mode
-----
scheduler              shared
default                <none>
subscriber-best-effort auto implicit
subscriber-video       <none>
subscriber-weight      <none>
subscriber-voice       <none>

```

- To display the settings for the QoS profile subscriber-triple-play, issue the **show qos-profile** command.

```
host1#show qos-profile subscriber-triple-play
```

```

qos-profile subscriber-triple-play:
t-class interface rule traffic queue drop
group type type class scheduler profile profile profile
-----
vlan node subscriber-weight
svlan node default
vlan queue best-effort subscriber-best-effort default default

vlan queue video subscriber-video default default
EF svlan node default
EF vlan queue voice subscriber-voice default default
statistics
profile
-----

default
default

default

```

- To display the attachments on all QoS profiles, issue the **show qos-profile references** command.

```

host1#show qos-profile references
qos profile attachment
-----
atm-default (qos-port-type-profile)
serial-default (qos-port-type-profile)
ethernet-default (qos-port-type-profile)
server-default (qos-port-type-profile)
subscriber-data-service vlan FastEthernet9/0.1
subscriber-triple-play vlan FastEthernet9/0.2
subscriber-triple-play vlan FastEthernet9/0.3

Port attachments: 4
Interface attachments: 3
Not attached: 0

```

- To display global and interface attachments on all of the QoS parameter instances, issue the **show qos-parameter references** command.

```

host1#show qos-parameter references
interface parameter name value
-----
global max-subscriber-bandwidth 2000000
global subscriber-weight 1
global max-subscriber-video-bandwidth 2000000
global max-100Kbps-voice-calls 1
FastEthernet9/0.2 max-subscriber-bandwidth 6000000
FastEthernet9/0.2 subscriber-weight 3
FastEthernet9/0.2 max-subscriber-video-bandwidth 2000000
FastEthernet9/0.2 max-100Kbps-voice-calls 1
FastEthernet9/0.3 max-subscriber-bandwidth 8000000
FastEthernet9/0.3 subscriber-weight 6
FastEthernet9/0.3 max-subscriber-video-bandwidth 3000000

```

```
FastEthernet9/0.3      max-100Kbps-voice-calls      3
FastEthernet9/0 svlan 1 max-subscriber-video-bandwidth 1000000
```

```
Global parameter instances: 4
Parameter instances reported: 13
```

- To display the queue forwarding rates for the VLANs on the Fast Ethernet interface in slot 9, port 0, issue the **show egress-queue rates** command.

```
host1#show egress-queue rates full interface fastEthernet 9/0
```

interface	class	traffic forwarded rate	aggregate drop rate	minimum rate	maximum rate
ethernet FastEthernet9/0	best-effort	*	*	0	100000000
vlan FastEthernet9/0.1	best-effort	*	*	0	2000000
vlan FastEthernet9/0.2	best-effort	*	*	0	6000000
	video	*	*	0	2000000
	voice	*	*	100000	100000
vlan FastEthernet9/0.3	best-effort	*	*	0	8000000
	video	*	*	0	3000000
	voice	*	*	300000	300000

```
Queues reported: 0
Queues filtered (under threshold): 0
* Queues disabled (no rate period): 8
**Queues disabled (no resources): 0
Total queues: 8
```

- To display the shared-shaper settings for the VLANs on the Fast Ethernet interface in slot 9, port 0, issue the **show qos shared-shaper** command.

```
host1#show qos shared-shaper interface fastEthernet 9/0
```

interface	resource	shared shaping rate	shaping rate	other
vlan Eth9/0.1	vlan node			
	A vlan queue best-effort	2000000		rate 2000000
vlan Eth9/0.2	vlan node			
	A vlan queue best-effort	6000000		rate 6000000
	A vlan queue video		2000000	
	A vlan queue EF voice		100000	
vlan Eth9/0.3	vlan node			
	A vlan queue best-effort	8000000		rate 8000000
	A vlan queue video		3000000	
	A vlan queue EF voice		300000	

```
Total shared shapers: 3
Total constituents: 10
Total shared shaper failovers: 0
Compound shared shapers are not supported.
```

10. To display the scheduler hierarchy for the Fast Ethernet interface in slot 9, port 0, issue the **show qos scheduler-hierarchy** command.

```

host1# show qos scheduler-hierarchy interface fastEthernet 9/0
Scheduler hierarchy for the default traffic-class group

```

interface	resource	shaping rate	shared shaping rate	assured rate or weight
ethernet Eth9/0	ethernet port			wgt 8
ethernet Eth9/0	ethernet queue			wgt 8
svlan Eth9/0 svlan 2	svlan node			wgt 8
vlan Eth9/0.1	vlan node			wgt 1
vlan Eth9/0.1	vlan queue best-effort		2000000	wgt 8
vlan Eth9/0.2	vlan node			wgt 3
vlan Eth9/0.2	vlan queue video	2000000		wgt 8
vlan Eth9/0.2	vlan queue best-effort		6000000	wgt 8
vlan Eth9/0.3	vlan node			wgt 6
vlan Eth9/0.3	vlan queue video	3000000		wgt 8
vlan Eth9/0.3	vlan queue best-effort		8000000	wgt 8

```

Scheduler hierarchy for traffic-class group EF

```

interface	resource	shaping rate	shared shaping rate	assured rate or weight
ethernet Eth9/0	ethernet group node EF			wgt 8
svlan Eth9/0 svlan 2	svlan node EF			wgt 8
vlan Eth9/0.2	vlan queue EF voice	100000		wgt 8
vlan Eth9/0.3	vlan queue EF voice	300000		wgt 8

Complete Configuration Example

You can use the complete configuration examples provided for each of the configurations in your own network. To customize the configuration example for your needs, copy the text into a text editor, and modify it.

To use the example for immediate use, copy it to the local console or Telnet session from which you access the router.

You can also save the example as a script (.scr) file that executes the commands as though they were entered at the terminal. For information about executing .scr files, see *JUNOS System Basics Configuration Guide*.

QoS Administrator Configuration

From Global Configuration mode:

```

! Configure traffic classes and traffic-class groups.
traffic-class best-effort
exit
traffic-class video
exit
traffic-class voice

```

```

fabric-strict-priority
exit
traffic-class-group EF auto-strict-priority
traffic-class voice
exit
!Configure the max-subscriber-bandwidth parameter definition.
qos-parameter-define max-subscriber-bandwidth
controlled-interface-type vlan
instance-interface-type vlan
range 512000 8192000
exit
!Configure the subscriber-weight parameter definition.
qos-parameter-define subscriber-weight
controlled-interface-type vlan
instance-interface-type vlan
range 1 6
exit
!Configure the max-subscriber-video parameter definition.
qos-parameter-define max-subscriber-video-bandwidth
controlled-interface-type vlan
instance-interface-type vlan
instance-interface-type svlan
range 1000000 5000000
exit
!Configure the max-100Kbps-voice-calls parameter definition.
qos-parameter-define max-100Kbps-voice-calls
controlled-interface-type vlan
instance-interface-type vlan
range 1 3
exit
! Configure the subscriber-best-effort scheduler profile.
scheduler-profile subscriber-best-effort
shared-shaping-rate max-subscriber-bandwidth auto
exit
! Configure the subscriber-video scheduler profile.
scheduler-profile subscriber-video
shaping-rate max-subscriber-video-bandwidth
exit
! Configure the subscriber-weight scheduler profile.
scheduler-profile subscriber-weight
weight subscriber-weight
exit
! Configure the subscriber-voice scheduler profile.
scheduler-profile subscriber-voice
shaping-rate max-100Kbps-voice-calls * 100000
exit
! Configure the subscriber-data-service QoS profile.
qos-profile subscriber-data-service
svlan node
vlan node scheduler-profile subscriber-weight
vlan queue traffic-class best-effort scheduler-profile subscriber-best-effort
exit
! Configure the subscriber-triple-play QoS profile.
qos-profile subscriber-triple-play
svlan node
vlan node scheduler-profile subscriber-weight

```

```

svlan node group EF
vlan queue traffic-class best-effort scheduler-profile subscriber-best-effort
vlan queue traffic-class video scheduler-profile subscriber-video
vlan queue traffic-class voice scheduler-profile subscriber-voice
exit
! Configure the ethernet-default QoS profile.
qos-profile ethernet-default
no ip node
no ip queue traffic-class best-effort
exit
! Attach the QoS profile to the VLAN and S-VLAN subinterfaces.
interface fastEthernet 9/0
encapsulation vlan
exit
interface fastEthernet 9/0.1
svlan id 2 1
ip address 192.1.1.1 255.255.255.0
interface fastEthernet 9/0.2
svlan id 2 2
ip address 192.2.1.1 255.255.255.0
exit
interface fastEthernet 9/0.3
svlan id 2 3
ip address 192.3.1.1 255.255.255.0
exit

```

QoS Client Configuration

From Global Configuration mode:

```

! Configure the max-subscriber-bandwidth, subscriber-weight,
max-subscriber-video-bandwidth, and max-100Kbps-voice-calls global parameter
instances.
qos-parameter max-subscriber-bandwidth 2000000
qos-parameter subscriber-weight 1
qos-parameter max-subscriber-video-bandwidth 2000000
qos-parameter max-100Kbps-voice-calls 1
! Configure a global parameter instance for individual DSLAMs.
interface fastEthernet 9/0
svlan 1 qos-parameter max-subscriber-video-bandwidth 1000000
exit
! Configure the basic-data service for Subscriber 1.
interface fastEthernet 9/0.1
qos-profile subscriber-data-service
exit
! Configure the basic triple-play service for Subscriber 2.
interface fastEthernet 9/0.2
qos-parameter max-subscriber-bandwidth 6000000
qos-parameter subscriber-weight 3
qos-parameter max-subscriber-video-bandwidth 2000000
qos-parameter max-100Kbps-voice-calls 1
qos-profile subscriber-triple-play
exit
! Configure the enhanced triple-play service for Subscriber 3.
interface fastEthernet 9/0.3

```

```
qos-parameter max-subscriber-bandwidth 8000000
qos-parameter subscriber-weight 6
qos-parameter max-subscriber-video-bandwidth 3000000
qos-parameter max-100Kbps-voice-calls 3
qos-profile subscriber-triple-play
exit
```

Published: 2009-10-07